

SERVICE INSTRUCTIONS

OILGEAR TYPE "PVV 540" OPEN LOOP PUMPS

PURPOSE OF INSTRUCTIONS

These instructions have been written to simplify and minimize your work of operating Oilgear type "PVV" pumps. Your acquaintance with the construction, principle of operation and characteristics of these units will help you attain satisfactory performance, reduce down-time and increase the units life. Some units have been modified from those described in this bulletin and other changes may be made without notice.

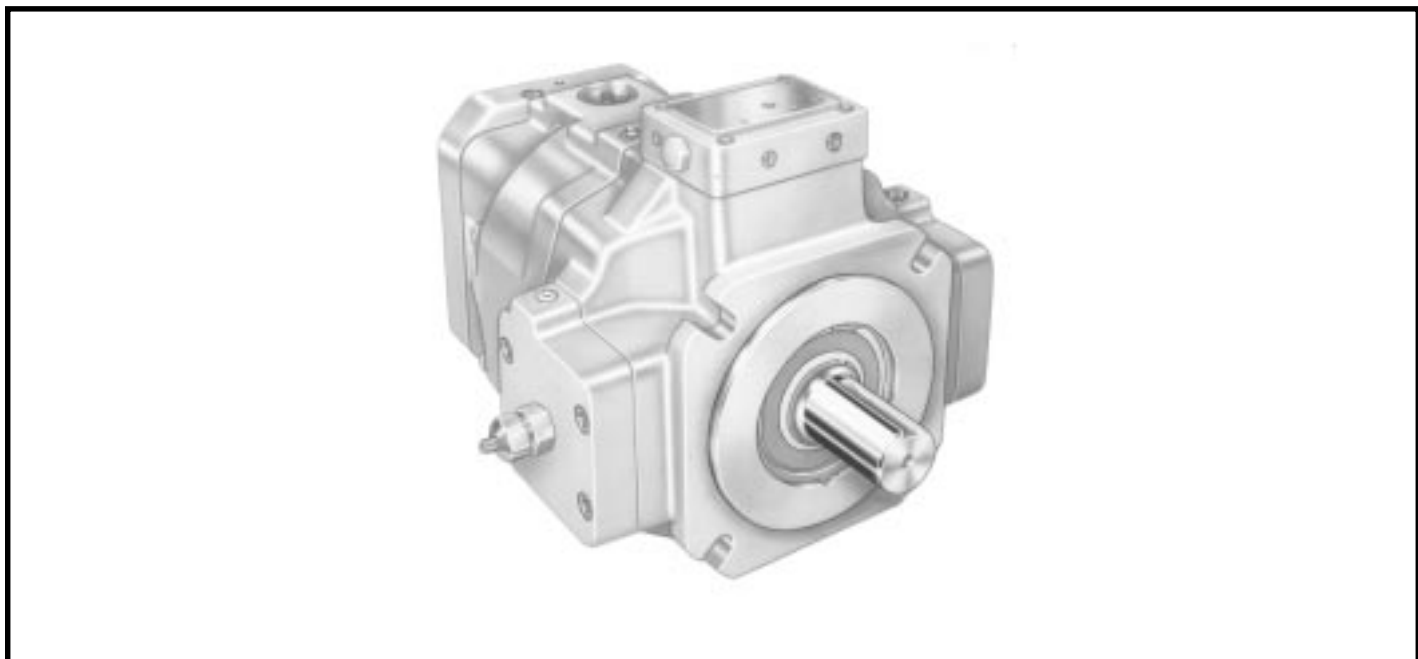

Figure 1. Typical Oilgear "PVV" Open Loop Pump (92013R).

REFERENCE MATERIAL

Fluid Recommendations	Bulletin	90000
Contamination Evaluation Guide	Bulletin	90004
Filtration Recommendations	Bulletin	90007
Piping Information	Bulletin	90011

I. PREPARATION AND INSTALLATION

A. MOUNTING

PUMP WITHOUT RESERVOIR. The pump may be mounted in any position. But, for convenience the recommended mounting position is with the driveshaft axis on a horizontal plane and with case drain "Port 1" to the top side. Secure the unit to a rigid mounting surface. See section "B" on "Piping Information".

PUMP WITH RESERVOIR. These units are usually fully piped and equipped, although it may be necessary to connect to super-charge circuit when used. Mount reservoir on level foundation with reservoir bottom at least six (6) inches above floor level to facilitate fluid changes.

THE OILGEAR COMPANY

2300 So. 51st. Street
Milwaukee, Wisconsin 53219

B. PIPING AND FITTINGS

See reference "Piping Information" bulletin and individual circuit diagram before connecting pump to system.

If "suction" inlet line is used, it should reach within 1 to 2 times its diameter from the bottom of reservoir – do not "bottom-out" tubes in reservoir. Inlet velocity must not exceed 7 fps (2,1 mps). Suction inlet should be unrestricted and have a minimum of fittings. An inlet strainer is not recommended. Consult The Oilgear Company for recommendations.

Arrange line from "case drain" so case remains full of fluid (non-siphoning). Case pressure must **not** be greater than 25 psi (1,7 bar). Each drain line must be separate, unrestricted, full sized and connect directly to the reservoir below the lowest fluid level. Provisions for opening this line without draining (siphoning) reservoir should be made.

WARNING:

Running pump in "Neutral" position (zero delivery) for long periods of time without supercharge (or a case bleed thru circuit) can damage the pump.

System and pump must be protected against over loads by separate high pressure relief valves. Install bleed valve(s) at highest point(s) in system.

C. POWER

Power is required in proportion to volume and pressure used. Motor size recommendations for specific applications can be obtained from The Oilgear Company. Standard low starting torque motors are suitable for most applications.

CAUTION:

Never start or stop unit under load unless system is approved by The Oilgear Company. It may be necessary to provide delivery bypass in some circuits.

D. DRIVE

See rotation direction plate on units' housing. Clockwise units should not be driven counter-clockwise nor counter-clockwise units driven clockwise. Use direct drive. Size and install coupling per manufacture's instructions.

CAUTION:

Do not drive coupling onto pump driveshaft. If fit is too tight, it may be necessary to heat coupling (see manufacture's instructions).

Misalignment of pump shaft to driveshaft should not exceed 0.005" (0,13 mm) Total Indicator Readout (TIR) in any plane.

E. FILTRATION

To assure long life from your hydraulic system, keep fluid clean at all times. See reference bulletins on "Filtration Recommendations" and "Contamination Evaluation". Oilgear recommends the use of a filter in an auxiliary (pilot) pump circuit. Replace filter element(s) when filter condition indicator reaches "change" area at normal fluid temperature. Drain and thoroughly clean filter case. Use replacement element(s) of same Beta 10 ratio (normally a ratio of 4 or more).

F. FLUID COOLING

When pump is operated continuously at rated pressure or frequently at peak load, auxiliary cooling of fluid may be necessary. Fluid temperature should not exceed the limits specified in Oilgear bulletin on "Fluid Recommendations".

G. AIR BREATHER

On most installations, an air breather is mounted on top of fluid reservoir. It is important for breather to be of adequate size to allow air flow in and out of reservoir as fluid level changes. Keep breather case filled to the "fluid level" mark. About once every six months, remove cover, wash screen in solvent, clean and fill case "level mark" and install dry screen. See manufacture's recommendations.

H. FLUID, FILLING, AND STARTING RECOMMENDATIONS

Refer to instruction plate on unit, reservoir, machine and/or "Fluid Recommendations" bulletin. Pump all fluid into reservoir through a clean (Beta 10 ratio 4 or more) filter. Fill reservoir to, but not above, "high level" mark on sight gage. Remove case drain line and refill pump case with hydraulic fluid.

Turn driveshaft a few times by hand with a spanner wrench to be sure parts are free.

Table 1. TORQUE to TURN SHAFT

Size Unit	540
Approx. Torque to turn driveshaft - foot pounds	35.6
Nm.	48,4

With pump under "no load", or with pump control at "neutral", turn drive unit on and off several times before allowing pump to attain full speed. The system can usually be filled by running the pump and operating the control. Watch fluid level mark in the reservoir and stop pump if level reaches "low" mark. Add fluid and start again. With differential (cylinder) systems, fluid must not be above "high level" when ram is retracted or below "low level" when extended. Bleed air from the system by loosening connections or opening petcocks at the highest point in the system. Close connection or petcocks tightly when solid stream of fluid appears.

II. CONSTRUCTION

Refer to Figure 2, 7 and 8. A driveshaft (301) runs through the center line of the front (001) and middle (002) pump housing as well as the valve plate (401). The front driveshaft bearing (302) supports one end of the shaft and the rear shaft bearing (403) supports the other end of the shaft. A cylinder barrel (101) is splined to the driveshaft. Pumping piston/shoe assemblies (102) in the cylinder are held against the swashblock wearplate (202) by a shoe retainer (104) and a hold down retainer (203). A cylinder spring (105), bearing against an inner cylinder spring guide (106) and driveshaft (301) acts against the outer cylinder spring guide (107) and a retaining ring (108), which is "snapped" into

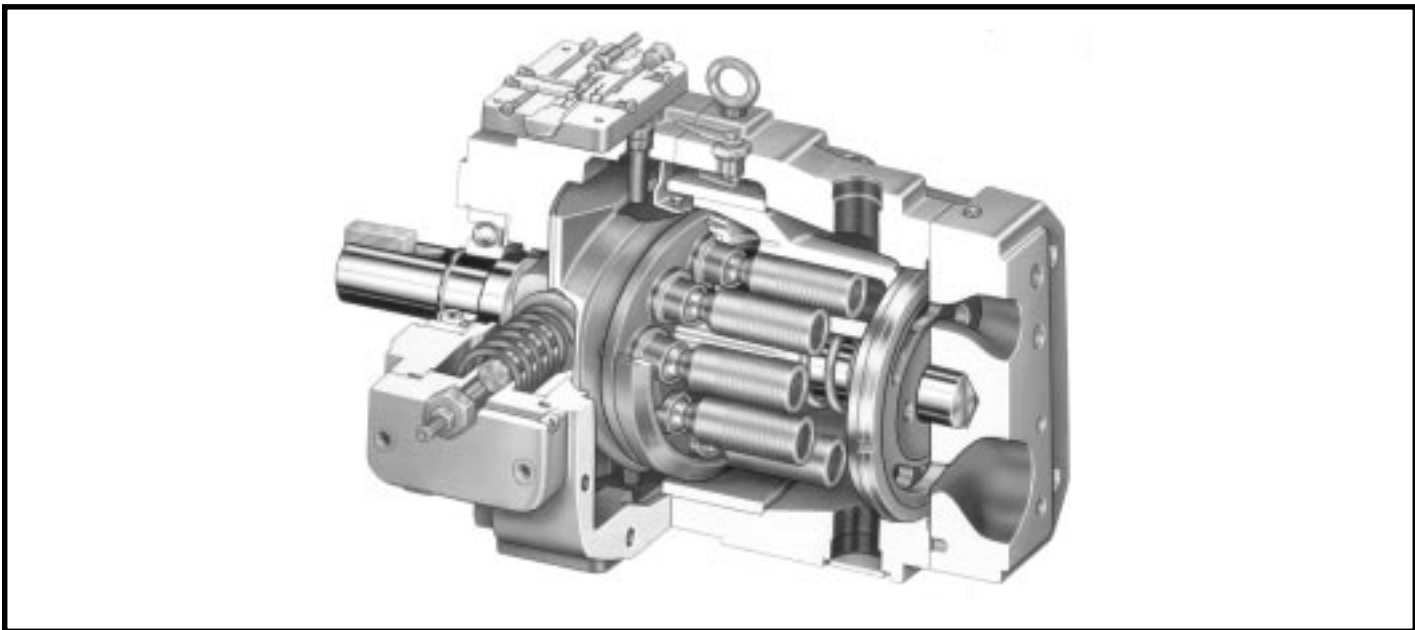

Figure 2. Cut-a-way view of typical Oilgear "PVV" Pump (92012R).

the cylinder barrel (101), forcing the cylinder and wearplate (103) against the port plate (1) and valve plate (401). The semicylindrical swashblock (201) can be swivelled in the saddle bearings (204) by operator pistons (501 and 502), which are operated by a control (covered in reference material). A stroke indicator arrow (803) gives a visual indication of the swashblock position.

The port plate (1) has two crescent shaped ports – one crescent connects the pumping piston (102) during the upper half revolution to the valve plate and port “A”. The other crescent port connects the pistons during the lower half revolution to the valve plate and port “B”.

(See Pages 4 and 5 for “III. PRINCIPLE OF OPERATION”)

IV. SPECIFICATIONS

See reference material, pump control material and individual application circuit for exceptions.

Table 2. NOMINAL PERFORMANCE DATA with 80-550 SSU viscosity fluids.

UNIT	THEORETICAL MAXIMUM DISPLACEMENT		RATED CONTINUOUS PRESSURE		MAXIMUM PRESSURE		FLOW RATE at rated continuous pressure 1200 rpm		POWER INPUT at rated continuous pressure and 1200 rpm	
	in. ³ /rev	ml/rev	psi	bar	psi	bar	gpm	lpm	hp	kw
	PVV 540	33.57	550	5000	345	5800	400	165	625,4	588

Table 3. NOMINAL DIMENSIONS and WEIGHTS without controls.

UNIT	LENGTH		WIDTH		HEIGHT		WEIGHT		PORT FLANGE		FACE MTG.
	in.	mm.	in.	mm.	in.	mm.	lbs.	kg.	Port A Pressure Connections	Port B Inlet Connections	FLANGE Bolt Circle
PVV540	22.5	647,7	22.8	577,9	15.5	393,7	750	340	2.500 SAE	4.000 SAE	12.4 in. B.C. 315 mm B.C.

(See Page 6 for “V. MALFUNCTIONS and CAUSES”)

III. PRINCIPLE OF OPERATION

A ONE-WAY PUMP DRIVEN CLOCKWISE (RIGHT HAND) IS DESCRIBED. DIAGRAMS ARE SHOWN FROM TOP (PLAN) VIEW.

SEE FIGURE 3. POSITION A. Rotating driveshaft clockwise turns the splined cylinder which contains the pumping pistons. A retaining plate holds the piston shoes against the swashblock. When the cylinder is rotated, the pistons move in and out of their bores as the piston shoes "ride" against the angled swashblock.

As the cylinder rotates, the individual piston bores are connected alternately to the upper (port "A") and lower (port "B") crescent shaped ports in port plate and valve plate. While connected to the lower side (suction) port "B", each piston moves outward, drawing fluid from port "B" into the piston bore until it's outermost stroke is reached. At that point, the piston bore passes from the lower crescent to the upper crescent port.

While rotating across the upper crescent, each piston is forced inward by the swashblock face. Each piston displaces fluid thru the upper crescent to port "A" until it's innermost stroke is reached. At that point, the piston bore passes from the upper crescent to the lower crescent again and the operating cycle is repeated.

SEE FIGURE 4. POSITION A/2. A study of the diagram will show that the linear stroke of the control pistons (501 and 502) set the angular position of the swashblock which determines the length of piston stroke (difference between outermost and innermost position) thereby determining the amount of delivery from the high pressure pump. In this example, the linear stroke of the control piston and the angle of the swashblock is one half former and pump delivery is one half the former delivery.

SEE FIGURE 5. POSITION N. Neutral position results when the control piston centers the swashblock. The swashblock face is now parallel to cylinder face and the angle is now zero. Therefore, no inward or outward motion of the pump pistons exits as piston shoe rotate around the swashblock face. The lack of inward and outward motion results in no fluid being displaced from the piston bores to the crescents in the port plate to the valve plate and subsequently no delivery from pump ports.

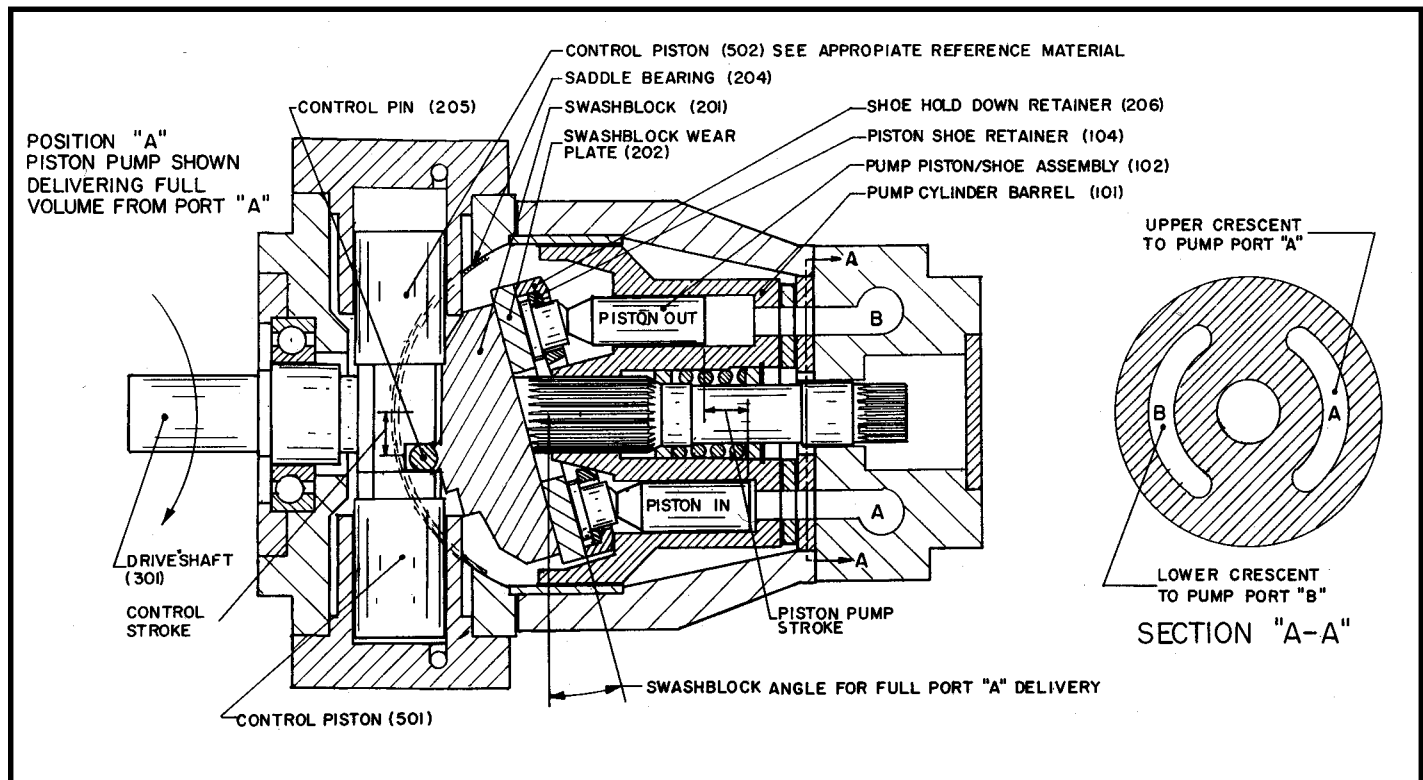

FIGURE 3. POSITION A (5V-12021-L)

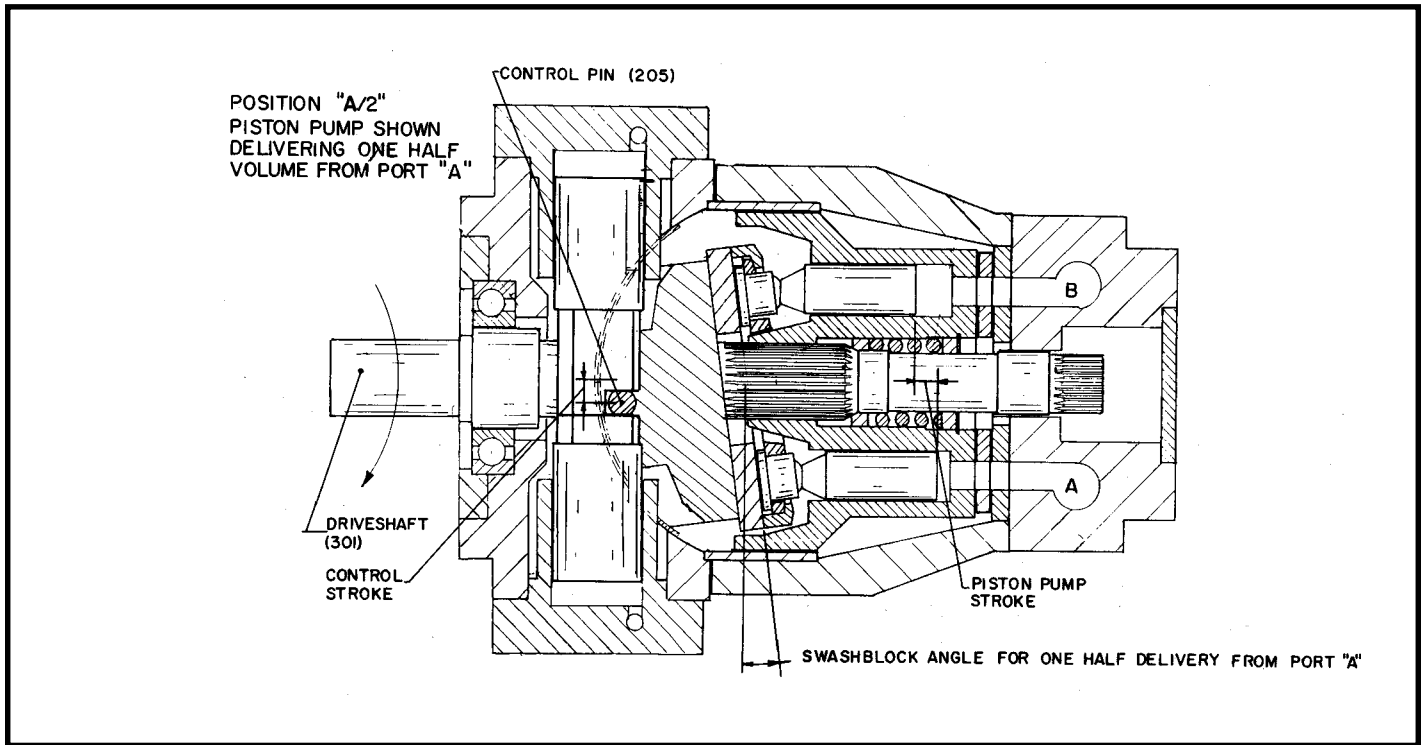

Figure 4. POSITION A/2 (5V-12021-L)

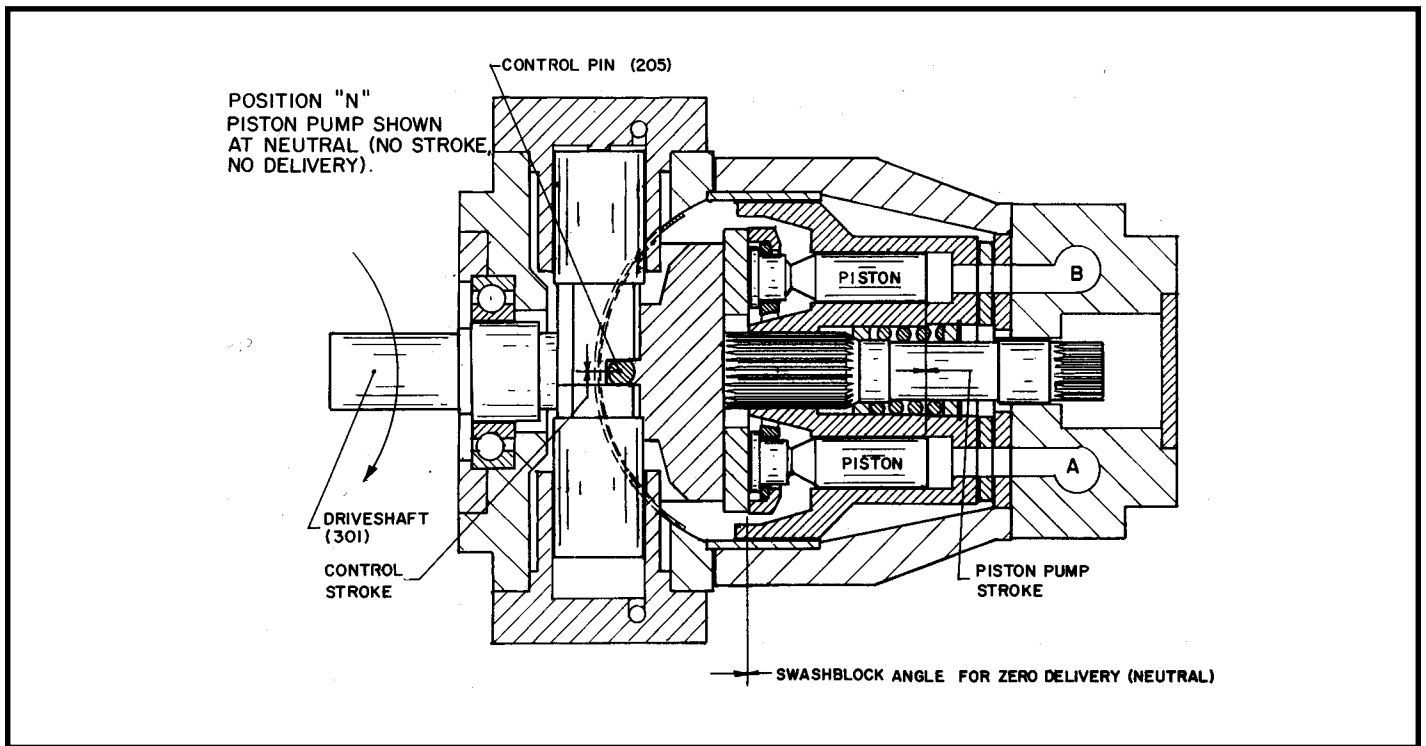

Figure 5. POSITION N (5V-12021-L)

(See Page 3 for "IV. SPECIFICATIONS")

V. MALFUNCTIONS AND CAUSES

A. UNRESPONSIVE OR SLUGGISH CONTROL

1. Faulty or binding control pistons – see referenced control instruction bulletin.
2. Insufficient control circuit pressure and/or volume – other auxiliary devices in circuit may “rob” volume from the pump control.
3. Swashblock (201) binding in saddle bearings (204).
4. Swashblock saddle bearings (204) worn or damaged.

B. INSUFFICIENT PUMP VOLUME

1. Delivery limited by faulty control (see appropriate control instruction bulletin).
2. Maximum volume stop (701) limiting pump stroke.
3. Obstructed suction circuit or insufficient supercharge volume.
4. Insufficient drive motor speed.
5. Worn or grooved cylinder wear plate (103) and/or port plate (1).
6. Worn pistons/shoe assemblies (102) or piston bores (101).
7. Worn or damaged piston/shoe assemblies (102) swashblock (201) or swashblock wear plate (202).

C. IRREGULAR OR UNSTEADY OPERATION

1. Faulty control- an oscillation stroke indicator pointer (803) is indicative of an unstable control.
2. Fluid level in reservoir is low or supercharge is insufficient.
3. Air entering hydraulic system.
4. Worn axial piston pump.
5. Faulty output circuit components (cylinders, motors, valves, etc.).

D. LOSS OF PRESSURE

1. Worn piston pump.
2. Worn or grooved cylinder wear plate (103) and/or port plate (1); wear plate and/or port plate separation from cylinder, each other or valve plate (401).
3. Worn pistons/shoes not seated on swashblock wear plate (202).
4. Piston shoe not seated on swashblock wear plate (202).
5. Faulty output circuit components (cylinders, motors, valves, etc.).

E. EXCESSIVE or HIGH PEAK PRESSURES

1. Faulty output circuit components (pay particular attention to relief valves).

F. EXCESSIVE NOISE

1. Pump incorrectly being stopped or started under load.

2. Low fluid level in reservoir or insufficient supercharge resulting in cavitation.
3. Air entering hydraulic system.
4. Fluid too cold or viscosity too high.
5. Suction line problem i.e. obstructions in line, line too long, line diameter too small or too many bends or loops in line.
6. Broken or worn piston/shoe assembly (102).
7. Worn or pitted bearings (302, 004, 403).
8. Pump rotating in wrong direction.

G. EXCESSIVE HEATING

1. Operating pump above rated or peak pressure.
2. Low fluid level in reservoir or insufficient supercharge.
3. Air entering hydraulic system.
4. Worn piston pump.
5. Worn or grooved cylinder wear plate (103) and/or port plate (1).
6. Faulty output circuit components (continuous blowing relief valves or slip through valves, cylinders, etc.).
7. Insufficient cooling provision or clogged coolers.

VI. TESTING AND ADJUSTING

WARNING: - Shut pump off and release pressure from the system before disassembling components. Failure to comply with these instructions could result in personal injury or death. **Blocking pressure line between pump and system (or pump) high pressure relief valve will result in damage and could result in serious personal injury.**

A. AXIAL PISTON PUMP

It is not recommended that stroke indicator be used to determine percent of slip stroke.

To check for worn piston pump, measurement of the leakage can be made from the case drain while the pump is under pressure. After the unit is warm, either install a flow meter in the drain line or have the flow from the drain line directed into a large container or reservoir. The pump case, must remain full of liquid during this test.

CAUTION:

Do not run a pump on stroke against a blocked output unless it is protected by a high pressure relief valve and then run no longer than necessary to check slip. Limit discharge to prevent dropping reservoir fluid below “low” level.

With an accurate high pressure gage in the pressure line, start the pump and stall (or block) output device to raise system pressure to maximum (as set by system relief valve). Read the flow meter, or time the case drain flow used to fill a known size container and calculate the flow rate in terms of cubic inches per minute (cipm). The leakage should conform with Table 4. Additional leakage indicates wear, but does not become critical until it impairs performance.

Table 4. NOMINAL CASE SLIP vs High Pressure at 1200 rpm (viscosities of 200 SSU).

Pump Size		Case Slip at Full Stroke and Indicated Pressure				
		1000 psi	2000 psi	3000 psi	4000 psi	5000 psi
540	cipm	600	1200	1800	2400	3000
	lpm	9,8	19,7	29,5	39,3	49,2

VII. DISASSEMBLY

A. GENERAL

Refer to figures 7 and 8. It will be advantageous to tag similar parts (particularly screws, plugs and o'rings during disassembly) to be certain they don't become confused with similar parts and to assure they will be returned to original location. Do not remove (locator) roll pins unless they are deformed or otherwise in need of replacement.

B. PREPARATION

For disassembly and assembly, a large crane capable of handling a 1000 lb. load will be necessary.

When disassembling or assembling unit, we recommend choosing a work area where no traces of dust, sand or other abrasive particles, which could damage the unit, are in the air. We also recommend not working near welding, sand blasting, grinding benches and the like. Place all parts on a CLEAN surface. To clean parts which have been disassembled, it is important to use CLEAN solvents. All tools and gages should be CLEAN prior to working with these units and new, CLEAN and threadless rags used to handle and dry parts.

WARNING: NEVER attempt to remove or install any component or assembly while unit and system is running. Always stop the pump, shut-off power and release pressure from the system before servicing or testing. Be sure provisions have been made so case drain line can be disconnected from the unit without causing the line to drain (siphon) the reservoir.

Disconnect case drain line from port "1", 1A" or "1B" and drain pump case through the remaining port (1, 1A or 1B) on the bottom of case. If plugs are inaccessible, it may be necessary to remove pump from mounting before draining it.

After removing pump from mounting, or before disassembling the middle pump housing (002) from the front pump housing (001) – cap or plug all ports and clean the outside of the unit thoroughly to prevent entry of dust into the system.

Refer to figures 7 and 8. Depending upon what part or parts are to be inspected, it may not be necessary to completely take apart all assemblies or disconnect the driveshaft and front housing mounting from the drive shaft. If **only** the port plate (1) is to be inspected, it is possible to remove valve plate group (G) only. The driveshaft group (I) can be removed, without disassembling the rest of the pump, to access front driveshaft bearing (302) and/or shaft seal (007).

C. CONTROL GROUP

See reference material for applicable information on the control your unit is equipped with. To disassemble the rotating group and/or swashblock group, it will be necessary to remove the control pistons (501 and 502). Note which bore (right or left side facing shaft) each piston (501 or 502) is removed from.

D. STROKE INDICATOR GROUP

Unscrew stroke indicator pin gland (801) and lift out assembly with block "V" packing (804) and Delrin washer (807).

E. MIDDLE HOUSING GROUP

Reaching in through the control piston (501 and 502) bores, remove the screws (210) which hold the swashblock (201) to its wear plate (202). It may be necessary to pull the swashblock towards the side you are working on to reach and turn the screws with an Allen wrench. After pump middle housing (002) has been separated slightly from the pump front housing (001), pry swashblock (201) from its' wearplate (202).

CAUTION:

Use eyebolts and a hoist to support the weight of the pump middle housing (002) assembly.

The cylinder spring (105) holds pump cylinder (101) and it's wear plate (103) against the port plate (1). To avoid damage, partially back out screws (014) on alternate corners, until they can be removed by finger pressure. Carefully move pump middle housing (002) laterally to prevent damage to the tail of the driveshaft, the shaft and cylinder splines. Shift assembly to a vertical position with the valve plate (401) resting on a clean surface. Remove gasket (003) and o'ring (011) from housing.

F. ROTATING GROUP

Thread eyebolts into swashblock wearplate (202) and use a hoist to lift wear plate/piston assembly from the cylinder. Remove screws (209) and pull swashblock wear plate (202) from assembly. Now, lift out and number each piston/shoe assembly (102), number its corresponding hole in the shoe retainer (104) as well as cylinder bore. Remove shoe retainer (104), the hold down retainer (203). Using threaded lifting holes provided, lift the pump cylinder (101) from the middle pump housing. If necessary, the cylinder wear plate (103) can be removed as well as the retaining ring (108), outer cylinder spring guide (107), cylinder spring (105) and inner cylinder spring guide (106). The cylinder bearing (004) is a pressed fit, but can be tapped out from inside the housing.

G. VALVE PLATE GROUP

CAUTION:

Use eyebolts and a hoist to support the weight of the valve plate.

If only valve plate is being removed, remember the cylinder spring (105) holds pump cylinder (101) and its wear plate (103) against the port plate (1). To avoid damage to these parts, partially back out screws (405) on alternate corners, until they can be unscrewed by finger pressure and remove the valve plate (401).

If middle housing group is removed, back out screws (405) and separate valve plate (401) from pump middle housing (002) and remove o'ring (019) from housing.

If necessary, remove screws (404) and lift port plate (1) from valve plate. Do not remove rear shaft bearing (403) unless replacement is necessary. If removed, note the direction the slot faces. Remove o'rings (019) and (407) from housing and valve plate.

H. SWASHBLOCK GROUP

Remove the shorter swashblock pin (005) from the bottom and the longer swashblock pin (006) from the top. Using eyebolts and hoist to support it, pull swashblock (201) laterally from the front pump housing (001) the length of the driveshaft. If necessary, stroke indicator lever (212) can be removed from swashblock. Remove saddle bearings (204) from front housing. If necessary, control pins (205) can be pulled out after removal of retaining ring (206).

I. DRIVESHAFT GROUP

To remove the driveshaft, it will be necessary to uncouple it from the driveshaft. It will also be necessary to remove the pump front housing from the mounting surface. Remove screws (307), lift out retaining plate (303) and driveshaft (301) can be pulled outward from the front pump housing. If necessary, retaining ring (305) can be removed and bearing (302) pulled from shaft. Seal retainer (304) and shaft seal (007) can be removed if necessary.

VII. INSPECTION

Clean all parts thoroughly. Inspect all seals and o'rings for hardening cracking or deterioration and replace if necessary. Check all locating pins for damage and all springs for cracking or signs of fatigue.

WARNING Always wear safety goggles when using solvents or compressed air. Failure to wear safety goggles could result in serious personal injury.

A. CONTROL GROUP

See applicable reference material on pump controls.

B. VALVE PLATE GROUP

Closely examine mating faces of port plate (1) and cylinder wear plate (103) for flatness, scratches or grooves. If faces are not flat and smooth, the cylinder will "lift off" from the port plate resulting in delivery loss and damage to the pump. Check rear shaft bearing (403). Replace any parts necessary.

C. STROKE INDICATOR GROUP

Check to be sure indicator pin (802) and stroke indicator lever (212) are not twisted or bent. All fits (pin into lever) should be snug or false vibration signals could result.

D. ROTATING GROUP

Check all piston/shoe assemblies (102) for smooth action in their bores. Check piston walls and bores for scratches, scouring or other signs of excessive wear. Replace if necessary. Piston shoes must pivot smoothly, but end play should not exceed 0.003" (0,076 mm). Check end play as follows: Place square end of piston on bench and hold down firmly. Pull on end of shoe with other hand and note end play. A good piston/shoe fit will have no end play, but the shoe must rotate and pivot on the piston ball. Inspect each shoe face for nicks or scratches. Measure shoe thickness [the part held between shoe retainer (104) and swashblock wear plate (202)]. All shoes must be equal within 0.001" (0,025 mm). If a single piston/shoe assembly (102) needs to be replaced, all piston/shoe assemblies must be replaced. Inspect cylinder bearing (004) and matching cylinder (101) surface for galling, pitting or roughness. Replace if necessary.

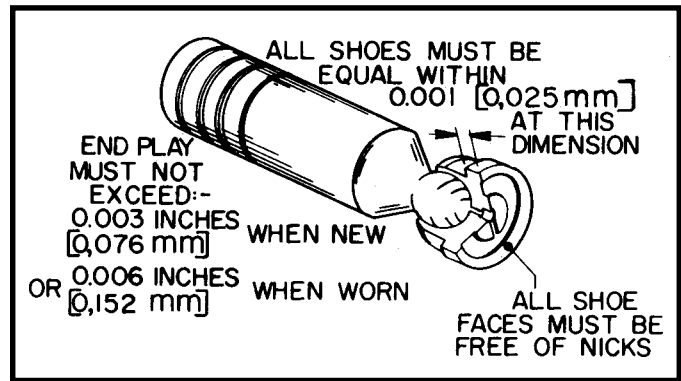

Figure 6. PISTON and SHOE INSPECTION (5V-12021-L).

E. SWASHBLOCK GROUP

Inspect swashblock wear plate (202) for scratches, grooves, cracks or uneven surface. Replace if defective. Inspect saddle bearings (204) for evidence of tearing, wear-thru or deterioration of bearing material. Check mating surface of swashblock for cracks or excessive wear. Replace if necessary. Swashblock movement in saddle bearings (204) must be smooth.

F. DRIVESHAFT GROUP

Check shaft seal (007) for deterioration or cracks. Replace if necessary. Check front driveshaft bearing (302) for galling, pitting, binding or roughness. Check shaft and its splines for wear. Replace any parts necessary.

IX. ASSEMBLY

Refer to figures 7 and 8. The procedure for assembling the pump is basically the reverse order of disassembly. During assembly, install new gaskets, seals and o'rings. Apply a thin film of CLEAN grease or hydraulic fluid to sealing components to ease assembly. If a new rotating group is used, lubricate thoroughly with CLEAN hydraulic fluid. Apply fluid generously to all wear surfaces.

A. VALVE PLATE GROUP

If used, place gasket (903) on cover plate (901) and secure cover to valve plate (401A) with screws (902).

Lay valve plate (401A or 401B) on bench with machine surface facing up. Press tailshaft bearing (403) into valve plate bore. When properly installed, bearing (403) should protrude upward 0.60" from the machined face with slot facing same direction as original bearing. Slide port plate (1) over tailshaft bearing and tap into position with a soft mallet. Position with shoulder screws (404). Screws (404) should **only position** port plate (not lock tightly in position). Place o'ring (019) in groove on back side of pump middle housing (002) locate o'ring (407) in housing and place screws (014) in their respective bores before mounting valve plate. Using screws (405) torque to 600 ft. lbs. Secure valve plate (401) to middle pump housing (002).

B. ROTATING GROUP

If removed, press pins (025) into cylinder bearing (004) and slide or tap bearing into pump housing (002). Place the inner cylinder spring guide (016), with chamfered edge facing in, into the center bore of the cylinder followed by spring (105), outer cylinder spring guide (107) and secure by snapping retaining ring (108) into groove in cylinder. If removed, press locating pins (109) into the rear end of the cylinder. Spread a coat of grease on the rear of the cylinder and locate cylinder wearplate (103) on the pins (109).

Lubricate port plate (1) and cylinder bearing (004) generously with hydraulic fluid. Place middle pump housing (002) on bench with open end up. Using eyebolts and a hoist carefully lift cylinder (101) assembly up and carefully lower into bearing (004) and housing (002).

If pistons and corresponding holes in retainer were marked upon disassembly, note which piston goes in which hole. Place shoe hold down retainer (203) on bench blocks, insert the shoe retainer (104) with chamfered side down and lower each piston/shoe assembly (102) into its corresponding hole. Lubricate this assembly liberally with hydraulic fluid. Place swashblock wearplate (202) with locating pin (211) in it on top of assembly and secure with Nylock threaded screws (209). Make sure parts are centered and clearance between retainer (203) and wear plate (202) are equal all the way around their circumferences. The shoes should be loose (.001" to .004" clearance) between the retainer and the wear plate. Place eyebolts in swashblock wear plate (202) and using a hoist, lift the assembly from the blocks. Check to be sure none of the pistons are binding in their shoes (swivel freely). Lubricate bores in cylinder. Lower assembly into pump case. Again, if pistons and corresponding bores in cylinder were marked upon disassembly, be sure pistons are returned to their original bores by working piston shoe/assemblies (102) into the cylinder while continuously lowering the wearplate assembly until the weight is no longer supported by the hoist. Remove the eyebolts and turn the assembly so location pin (211) is positioned at the bottom of the housing. Pin will be used to position wearplate (202) on swashblock (201). Grease o'ring (207) and locate in the recesses of wearplate.

C. SWASHBLOCK GROUP

Place saddle bearings (204) on locating pins (016) and tap into place. Insert both control pins (205) in swashblock (201) and secure with retaining rings (206). Secure stroke indicator level (212) on swashblock with screw (208). Slide swashblock (201) on machined pads into front pump housing (001) until the swashblock (201) is seated in the saddle bearings (204).

To hold swashblock (201) in place, screw in upper (longer) swashblock pin (006) and lower (shorter) swashblock pin (005) with o'rings (012) in place. With pins in place, swashblock should be able to swivel freely.

D. DRIVESHAFT GROUP

If removed, press shaft seal (007) into front pump housing (001) with "U" opening of seal towards inside of housing. Place seal retainer (304) over seal. Press shaft bearing (302) onto driveshaft (301) and secure with retainer ring (305). Slide driveshaft through seal (007) and swashblock (201). Tap on end of shaft to seat bearing in front pump housing and secure retaining ring (303) with screws (307).

E. FRONT AND MIDDLE HOUSING GROUP ASSEMBLY

Can be accomplished either in vertical position or in horizontal position.

VERTICAL – (When using this method, it may be easier to install the driveshaft group after bringing the front and middle housing together). With middle pump housing (002) opening towards top, spread grease on housing surface and place pump housing gasket (003) and o'ring (011) on pump front housing. Using eyebolts and hoist lift front pump housing assembly into

a vertical position. Lubricate driveshaft and cylinder splines with hydraulic fluid. Carefully lower assembly into the middle housing so driveshaft passes through the cylinder. Be sure the stroke indicator lever (212) clears the side of the housing and continue to lower assembly so slot in the indicator lines up with the hole for bushing (801). Also be sure the hold in swashblock (201) lines up with locating pin (211) in swashblock wear plate (202) and locating pin (017) engages both housing.

HORIZONTAL – (**Procedure to use if front housing was not removed from "mounting"**). Use eyebolts and a hoist to place middle pump housing (002) in a horizontal (axis) position. Spread grease on the open face of the front pump housing and locate pump housing gasket (003) and o'ring (011) on the housing. Using eyebolts and a hoist lift the middle pump housing (002) and valve plate (401). Grasp and carefully move it laterally so the tail end of the drive shaft passes through the cylinder (101) (without harming splines), through the port plate (1) and through the rear shaft bearing (403). Be sure the hole in swashblock (201) lines up with locating pin (211) in swashblock wear plate (202) and locating pin (017) engages both housings.

F. FINAL HOUSING ASSEMBLY

The front pump housing (001) is held apart from the middle pump housing (002) due to the force of the cylinder spring (015), unless the driveshaft group is installed after bringing the front and middle housing together. Using screws (014) on alternate corners, pull the two assemblies together. Torque each screw to 240 ft. lbs. With case halves secured, put pump into a horizontal position (if not already in one) with stroke indicator (803) side up.

Reaching through the control piston (501 and 502) bores, secure both sides of swashblock (201) to wear plate (202) with screws (210). It may be necessary to shift the position of the swashblock to access the counter bore and holes so screws (210) can be pushed through and engage the threads in the swashblock wear plate (202). It may also be necessary to pull the swashblock towards the side you are working on so you can reach in the housing and turn the screws with an Allen wrench.

G. STROKE INDICATOR

Place stroke indicator arrow (803) on stroke indicator pin (802) securing with screw (806). Insert pin into stroke indicator gland (801) and place o'ring (805) on gland. Slip block "V" packing (804) on pin (with "V" opening pointed towards pump center line) and then place Delrin washer (807) on pin and lock with retaining ring (808). Insert assembly into pump housing so the pin (802) taper is inserted in stroke indicating level (212) fork. Tighten down gland (801) to force the taper pin into the fork.

H. CONTROL GROUP

See reference material for applicable information on the control your unit is equipped with. See appropriate control reference for control group mounting.

SEE SECTION "I. PREPARATION and INSTALLATION".

PARTS DRAWINGS ON PAGES 10 AND 11

PARTS LIST ON PAGES 12 AND 13

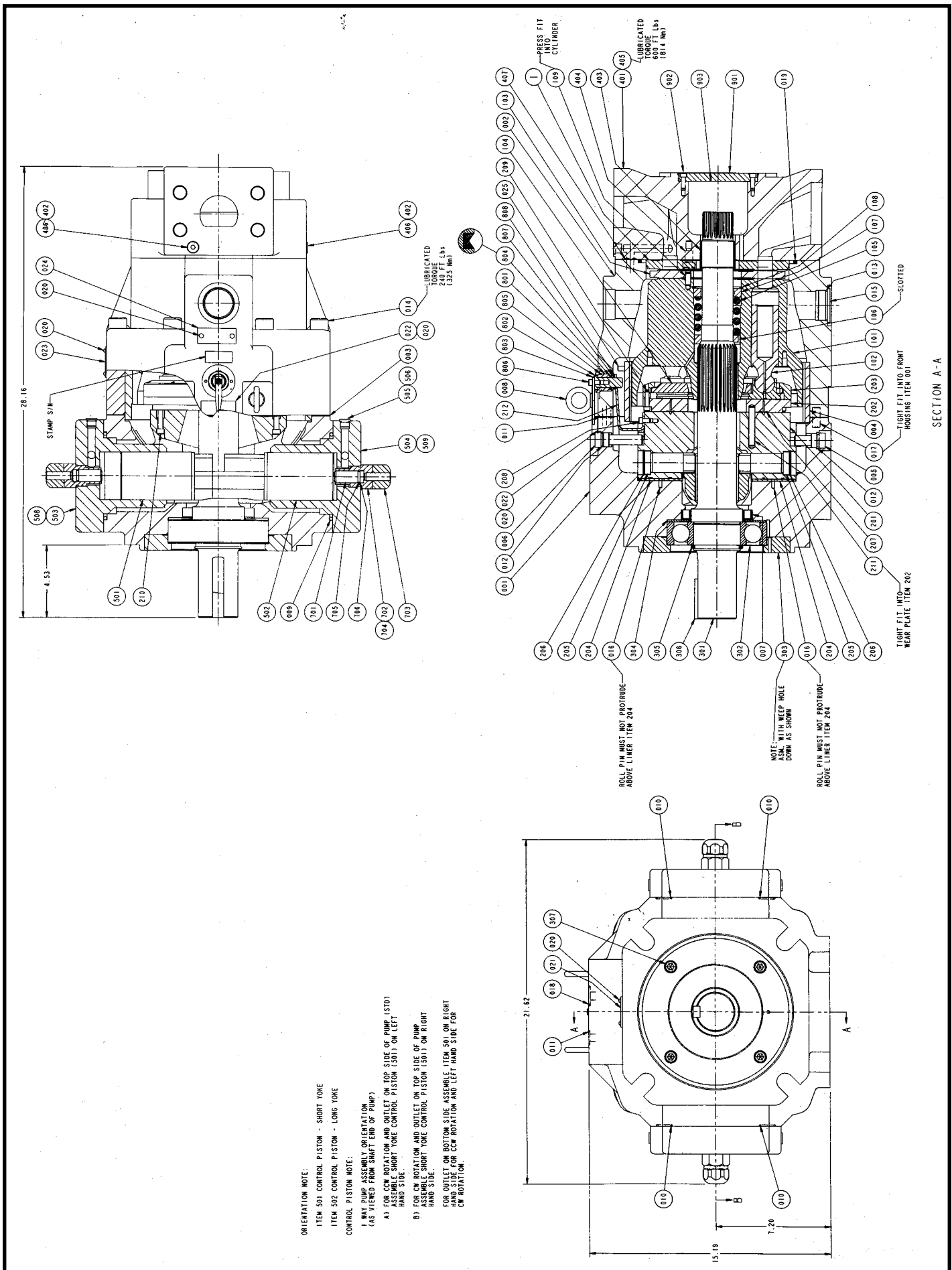

Figure 7. Cross Section Drawing (515888 sht. 1).
 Bulletin 947028

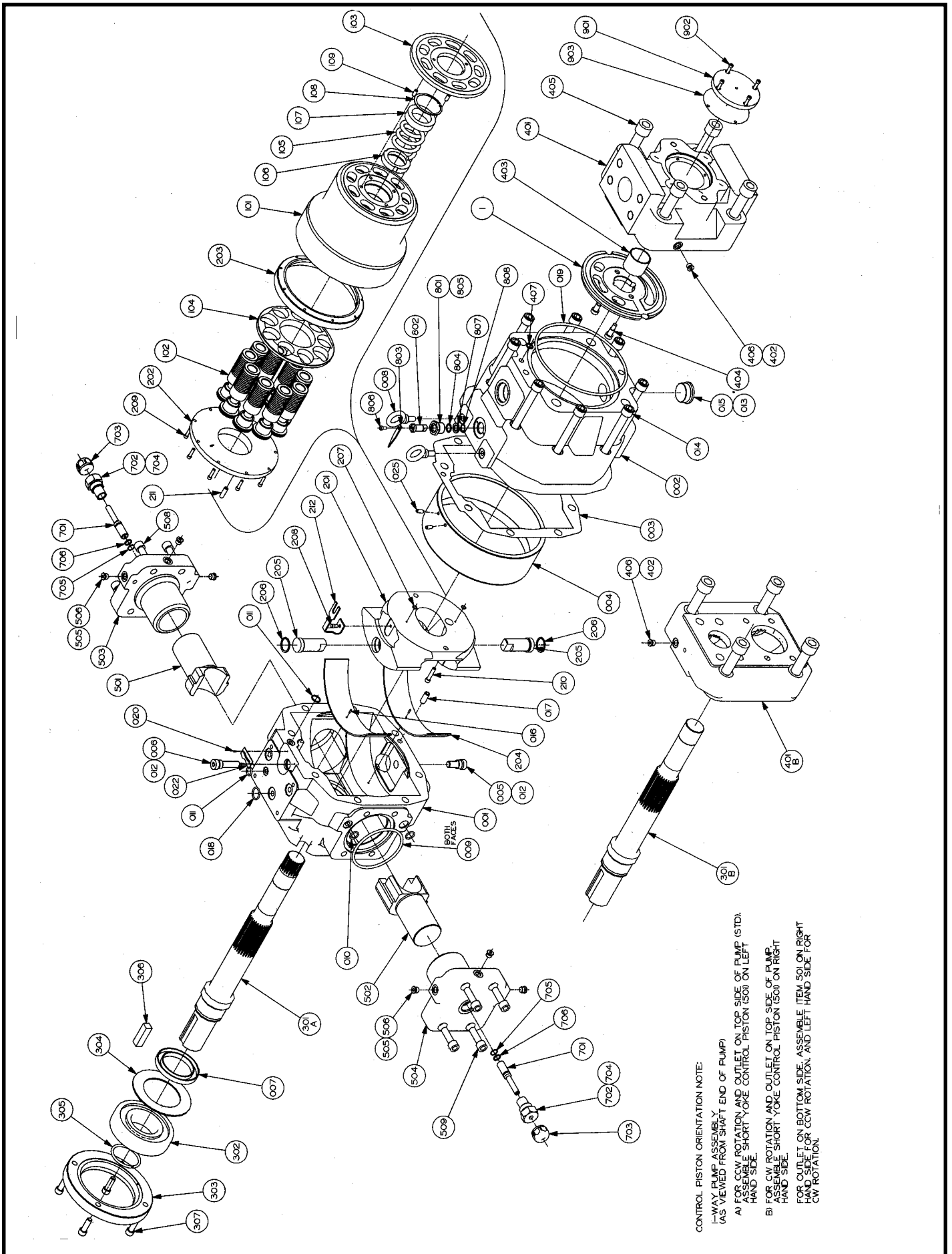

Figure 8. Exploded Parts Drawing (51888 sht. 2).

Parts list on page 12 (fold-out)

X. PARTS LIST

Parts used in this assembly are per Oilgear specifications. Use Oilgear parts to insure compatibility with assembly requirements. When ordering replacement parts, be sure to include pump type designation, serial number, bulletin number and item number. To assure seal and packing compatibility specify type of hydraulic fluid used.

ITEM NO.	DESCRIPTION	ITEM NO.	DESCRIPTION	ITEM NO.	DESCRIPTION
1	Plate, Port	200	SWASHBLOCK ASSEMBLY GROUP	500	CONTROL HEAD ASSEMBLY
000	COMMON ASSEMBLY GROUP	201	Swashblock	501	Piston, Full Area Short Yoke
001	Housing, Pump Front	202	Wear Plate, Swashblock	502	Piston, Full Area Long Yoke
002	Housing, Pump Middle	203	Retainer, Shoe Hold Down	503	Cap
003	Gasket, Pump Housing	204	Bearing, Saddle	504	Screw, Sock. Hd. Cap
004	Bearing, Pump Cylinder	205	Pin, Control	505	Seal, O'ring
005	Pin, Lower Swashblock Locating	206	Ring, Retainer	506	Plug, SAE
006	Pin, Upper Swashblock Locating	207	Seal, O'ring		
007	Seal, Shaft	208	Screw, Sock. Hd. Cap	700	VOLUME STOP ASSEMBLY
008	Eyebolt, Lifting	209	Screw, Sock. Hd. Cap	701	Stop, Min./Max. Volume
009	Seal, O'ring	210	Screw, Sock. Hd. Cap	702	Gland, Volume Stop
010	Seal, O'ring	211	Pin, Swashblock Wear Plate Locating	703	Nut, Lock
011	Seal, O'ring	212	Lever, Stroke Indicator	704	Seal, O'ring
012	Seal, O'ring			705	Seal, O'ring
013	Seal, O'ring	300	DRIVESHAFT ASSEMBLY GROUP	706	Ring, Back-up
014	Screw, Sock. Hd. Cap	301A	Driveshaft, w/Keyway, (Rear Ported Pump)		
015	Plug, SAE	301B	Driveshaft, w/Keyway, (Side Ported Pump)	800	STROKE INDICATOR ASSEMBLY
016	Pin, Saddle Bearing Locating	302	Bearing, Front Driveshaft	801	Gland, Indicator Pin
017	Pin, Housing Locating	303	Retainer, Plate (Shaft)	802	Pin, Stroke Indicator
018	Seal, O'ring	304	Retainer, Seal	803	Arrow, Indicator
019	Seal, O'ring	305	Ring, Shaft Bearing Retainer	804	Packing, Block "V"
020	Screw, Drive	306	Key, Driveshaft	805	Seal, O'ring
021	Nameplate, Rotation	307	Screw, Sock. Hd. Cap	806	Screw, Sock. Hd. Cap
022	Nameplate, Stroke Indicator			807	Washer, Derlin
023	Nameplate, Identification	400	VALVE PLATE ASSEMBLY GROUP	808	Ring, Retainer
024	Nameplate, Caution	401A	Valve Plate, Side Ported		
025	Pin, Cylinder Bearing Locating	401B	Valve Plate, Rear Ported	900	COVER PLATE ASSEMBLY
		402	Plug, SAE	901	Plate, Cover
100	ROTARY ASSEMBLY GROUP	403	Bearing, Rear Shaft	902	Screw, Sock. Hd. Cap
101	Barrel, Pump Cylinder	404	Screw, Shoulder	903	Gasket, Rear Cover
102	Assembly, Piston/Shoe	405	Screw, Sock. Hd. Cap		
103	Wear Plate, Cylinder	406	Seal, O'ring		
104	Retainer, Shoe	407	Seal, O'ring		
105	Spring, Cylinder				
106	Guide, Inner Cylinder Spring				
107	Guide, Outer Cylinder Spring				
108	Ring, Retainer				
109	Pin, Cylinder Wear Plate Locating				

O'RING and BACK-UP RING SIZES
Cross Section x O.D. Duro +5

ITEM NO.	PUMP SIZE	540
009	1/4 x 5-5/8	70
010	1/8 x 1	90
011	3/32 x 7/8	90
012	910 ARP	70
013	924 ARP	70
018	1/8 x 1-1/4	90
019	1/4 x 10	70
207	1/16 x 1/2	90
406	906 ARP	90
407	3/32 x 3/4	90
505	906 ARP	90
705	1/16 x 3/4	90
805	912 ARP	70
904	1/8 x 5	70

NOTES:

FOLD OUT FOR PARTS DRAWING

XI. AFTER SALES SERVICES

Oilgear builds products that last. However, it is the nature of this type of machinery to require proper maintenance regardless of the care that goes into its manufacture. Oilgear has several service programs to help you.

“STAY-ON-STREAM” SERVICE

By signing up for Oilgear’s “Stay-On-Stream” program you can prepare for problems before they happen. Certain field tests such as fluid testing, slip testing and electronic profile recording comparisons can be performed by our field service people or your own trained personnel. These tests can indicate problems before they become “down-time” difficulties.

SERVICE SCHOOLS

Oilgear holds schools to train your maintenance personnel. A “general” hydraulic or electronic school is conducted in our Milwaukee plant on a regular basis. “Custom” schools, specifically addressing your particular hydraulic and electrohydraulic equipment can be conducted in your plant.

SPARE PARTS AVAILABILITY

Prepare for future needs by stocking Oilgear original factory parts. Having the correct parts and necessary skills “in-plant” enables you to minimize down-time. Oilgear has developed parts kits to cover likely future needs. Oilgear field service technicians also stand ready to assist your maintenance people in trouble-shooting and repairing equipment.

OILGEAR EXCHANGE SERVICE

Standard replacement pumps and motors are available to users of Oilgear equipment where comparable units will be returned in exchange. When standard replacements must be modified to replace units which are special, shipment will depend on availability of parts, assembly and test time necessary.

To obtain this service, place an order for an exchange unit and provide the serial number and type designation. The replacement unit will be shipped F.O.B. our factory, Milwaukee, Wisconsin. User retains the replacement and returns the worn unit prepaid to The Oilgear Company for reconditioning and test. When the unit is reconditioned or stocked, the user is billed the cost of reconditioning or a flat rate exchange price if one has been applied to that particular type of unit.



THE OILGEAR COMPANY

2300 So. 51st. Street
Milwaukee, Wisconsin 53219