

TANDEM PUMP INSTALLATION DRAWING

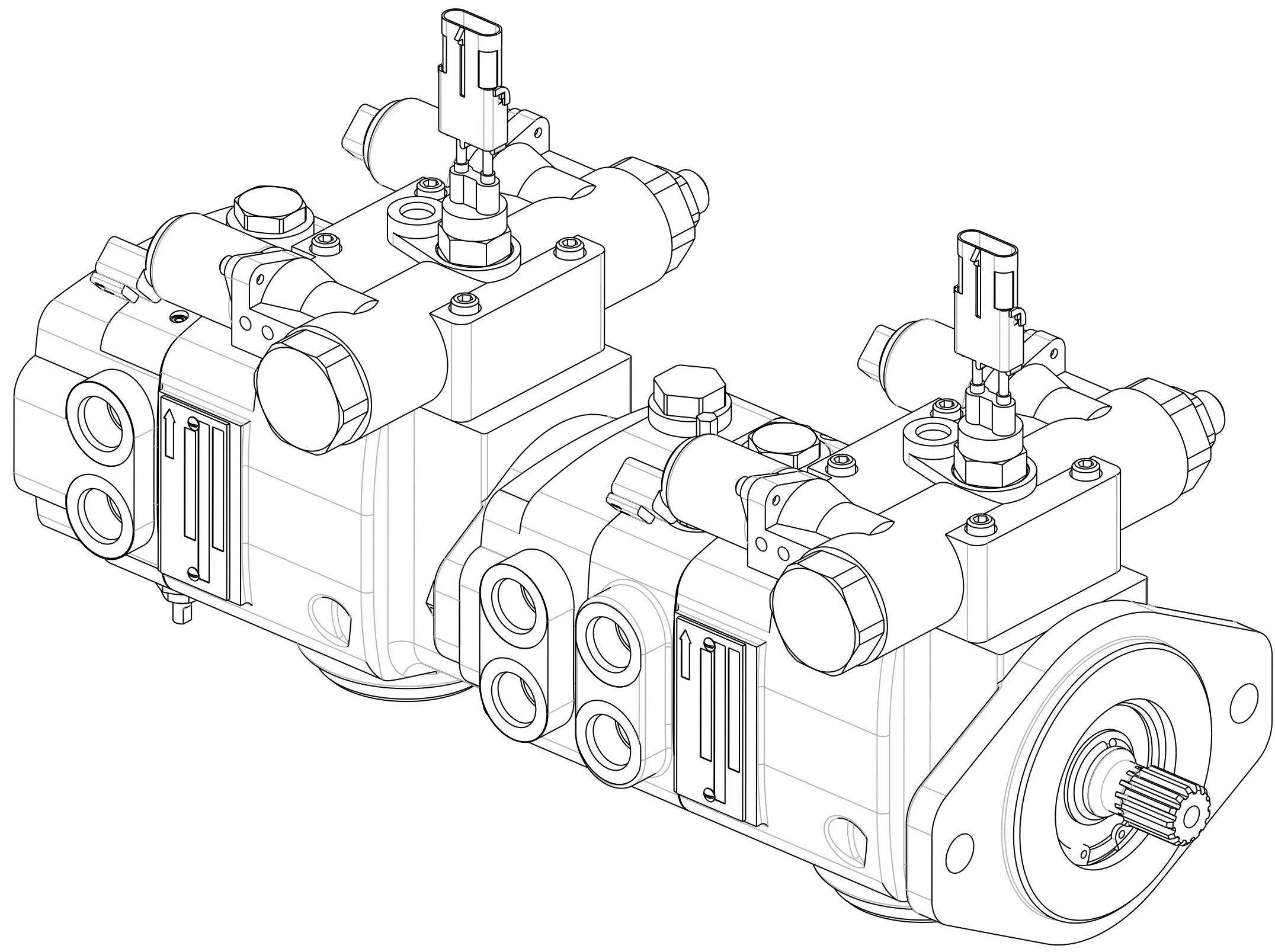

GENERAL NOTES:

- 1) RIGHT HAND (CW) ROTATION UNITS SHOWN.
- 2) THESE UNITS ARE DESIGNED TO RUN WITH CASE FULL OF FLUID AT ALL TIMES. FILL CASE BEFORE STARTING AND CONNECT DRAIN LINES ACCORDINGLY.
- 3) NUMERICAL DIMENSIONS GIVEN IN INCHES.
- 4) TOTAL WEIGHT = 80 LBS

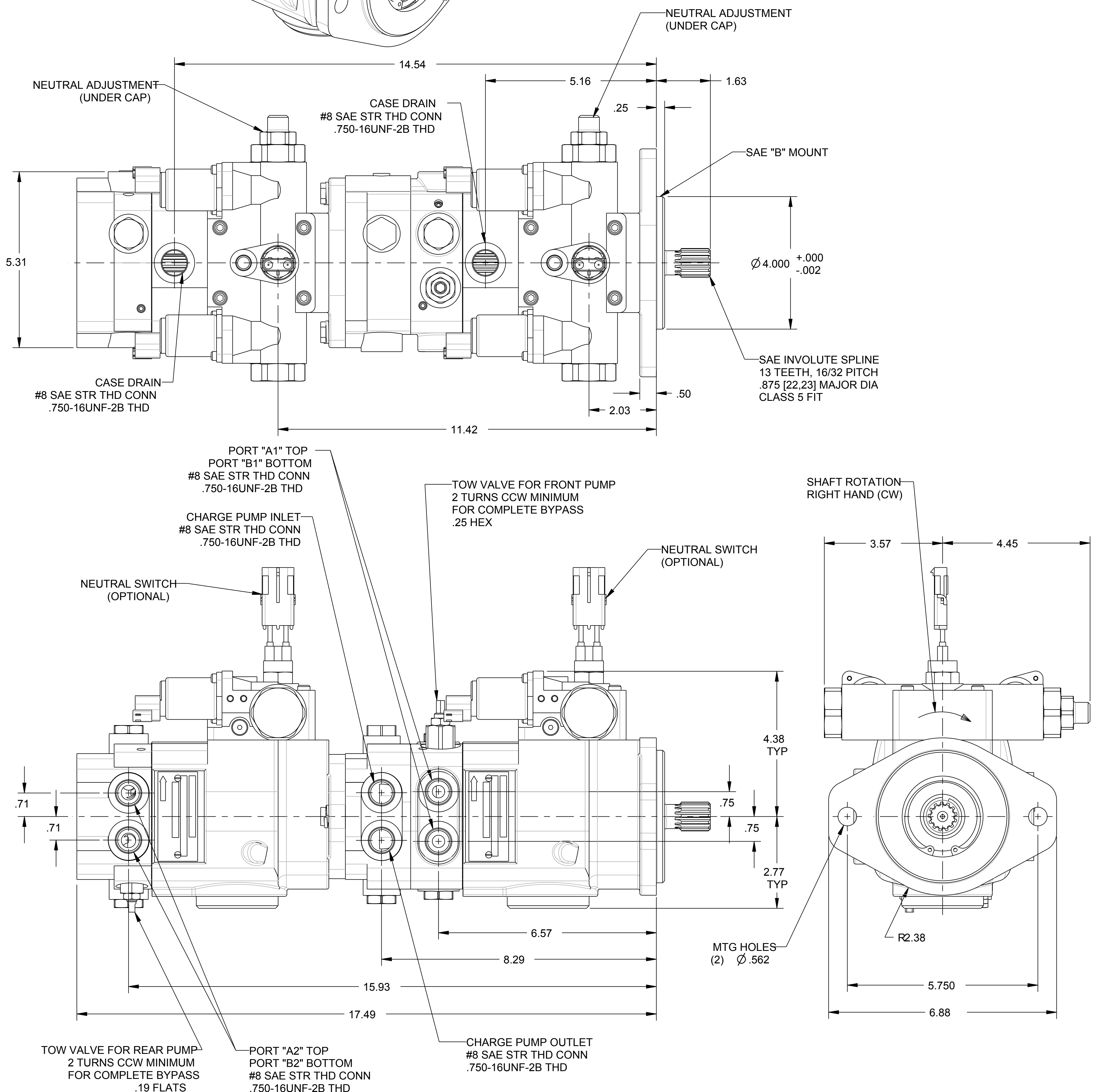

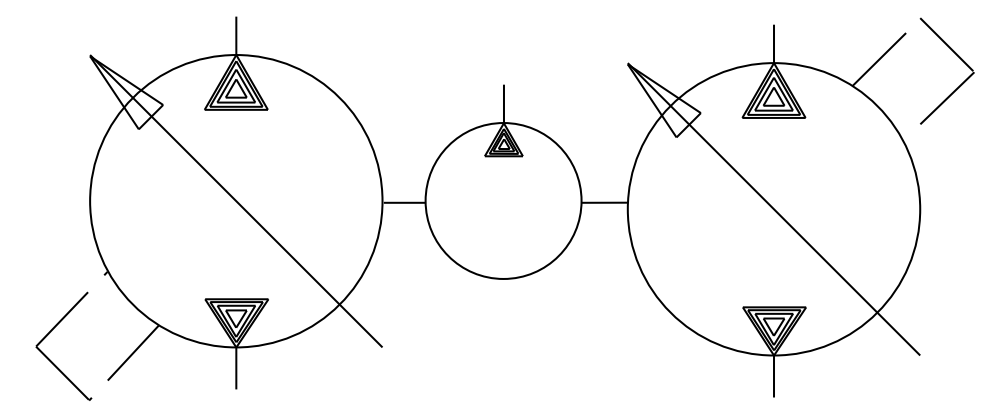

TANDEM PUMP INSTALLATION DRAWING

