

Oilgear

PVV Open Loop Pumps

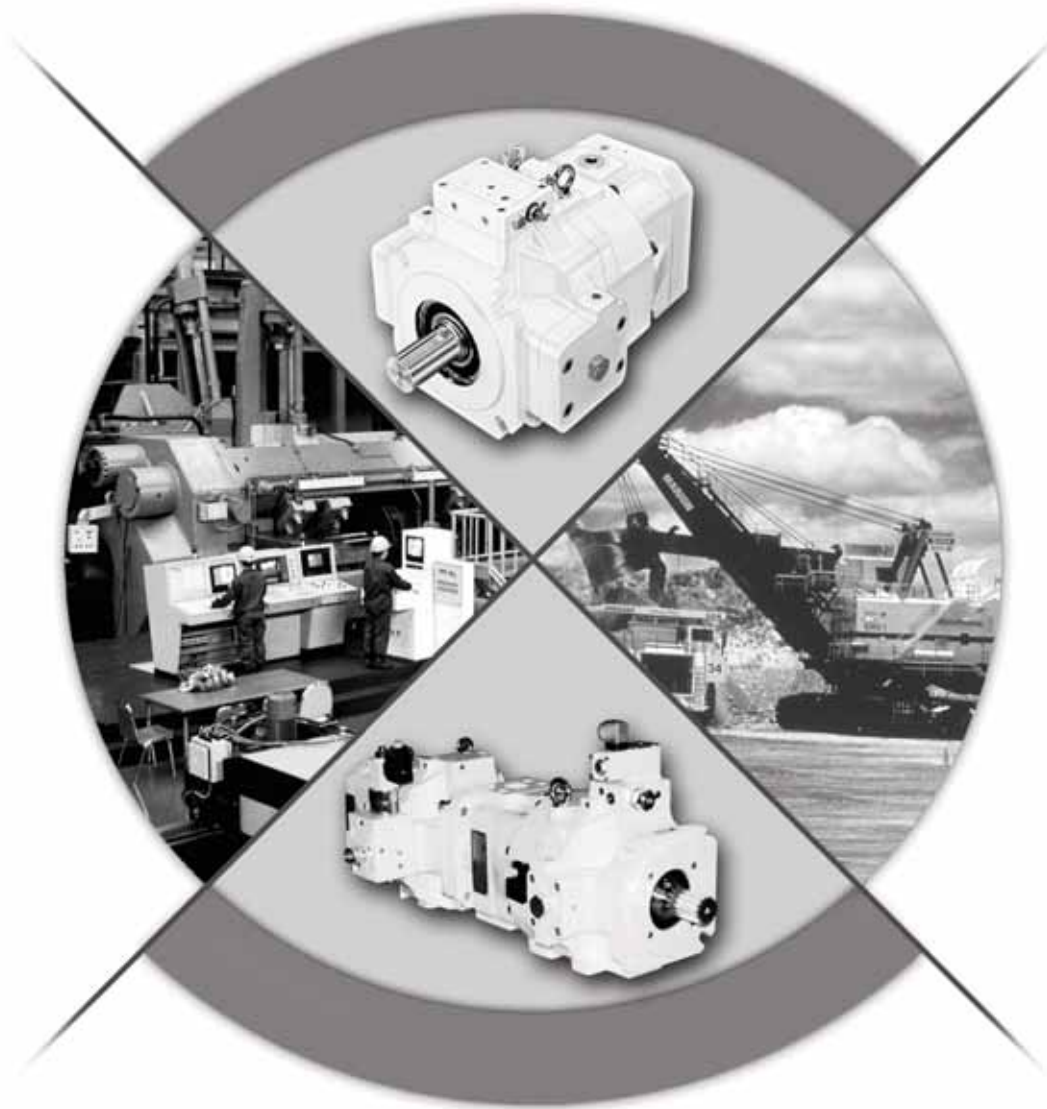

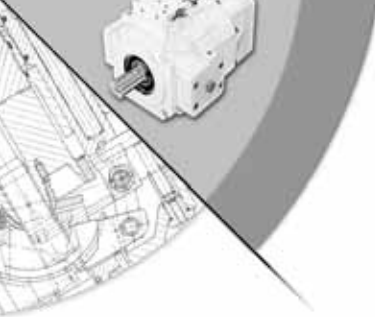

Table of Contents

Performance Assurance	page 3
Features and Benefits	4-5
Specifications	6
Controls	
Single Pressure Compensator	7
Single Pressure Compensator w/Load Sense	7
Single Pressure Compensator w/Horsepower Limit	8
Single Pressure Compensator w/Horsepower Limit & Load Sense	8
Single Soft Start Pressure Compensator	9
Single Soft Start w/Load Sense	9
Single Soft Start w/Horsepower Limit	10
Single Soft Start w/Horsepower Limit & Load Sense	10
Dual Pressure Compensator	11
Triple Pressure Compensator	11
Dual Soft Start	12
Triple Soft Start	12
Electronic Proportional Pressure Compensator	13
Remote Pressure Compensator w/Horsepower Limiter	13
Remote Pressure Compensator	13
Remote Electronic Servo Valve	14
Solenoid Operated Two Volumes	14
Electronic Servo Valve	14
Fixed	15
Force Amplifier - Proportional	15
Performance Curves	
Efficiency, Delivery, Horsepower, Etc.	16-17
Inlet Suction/Supercharge	18-19
Sound	20
Multiple Pumps	
Pump Combinations	21
Ordering Information	22-23

PERFORMANCE ASSURANCE – STANDARD WITH EVERY OILGEAR PUMP



Oilgear
PERFORMANCE
ASSURANCE

Every Oilgear product is shipped to you with our Performance Assurance — a corporate commitment to stay with your installation until our equipment performs as specified.

Hydraulic equipment and systems have been Oilgear's primary business since 1921. For decades, we have developed hydraulic techniques to meet the unique needs and unusual fluid power problems of machinery builders and users worldwide, matching fluid power systems to a tremendous range of applications and industries. Our exclusive Performance Assurance program is built upon that strong foundation.

As a customer, you also benefit from access to Oilgear's impressive technical support network. You'll find factory trained and field-experienced application engineers on staff at every Oilgear facility. They are backed by headquarters staff who can access the records and knowledge learned from decades of solving the most difficult hydraulic challenges.

When your design or purchase is complete, our service is just beginning. If you ever need us, our Oilgear engineers will be there, ready to help you with the education, field service, parts and repairs to assure that your installation runs smoothly — and keeps right on running.

Oilgear Performance Assurance

PVV Open Loop Pumps

Compact, computer optimized, high horsepower pumps with Oilgear's time proven rotating group.

- Up to 587 horsepower (438 kw) in a small package enables compact, light weight installation package.
- Proven designed rotating group with 25 years of heavy duty applications.
- Engineered with proven materials and finite element analysis.

Swashblock and integral saddle with special polymerous bearings.

- Allows running with low viscosity or other special fluids.
- Permits consistent control reaction.
- Eliminates troublesome yoke bearing.
- Provides long life.

Keyed or splined shaft.

Patented pressure lubricated swashblock design.

- Provides high performance for high cycling operation.

Sealed front shaft bearings.

- Allows operation with low viscosity or other special fluids.
- Permits side loading.

Adjustable minimum and maximum volume stops (standard).

Piston shoes run on flat steel thrust plate.

- Hydrostatically balanced piston shoe assembly provides long life.
- Allows higher pressure operation, 5000-6500 psi (350-450 bar).
- Thrust plate is easily re-machined or replaced reducing repair costs.
- Retained shoe mechanism allows high speed operation.

Industry proven mechanically retained shoe.

- Retained shoe mechanism allows speeds up to 1800 rpm.

Replaceable hardened cylinder wear plate and bronze port plate.

- Provides greater resistance to contamination.
- Flat plates are easily re-machined or replaced reducing repair costs.

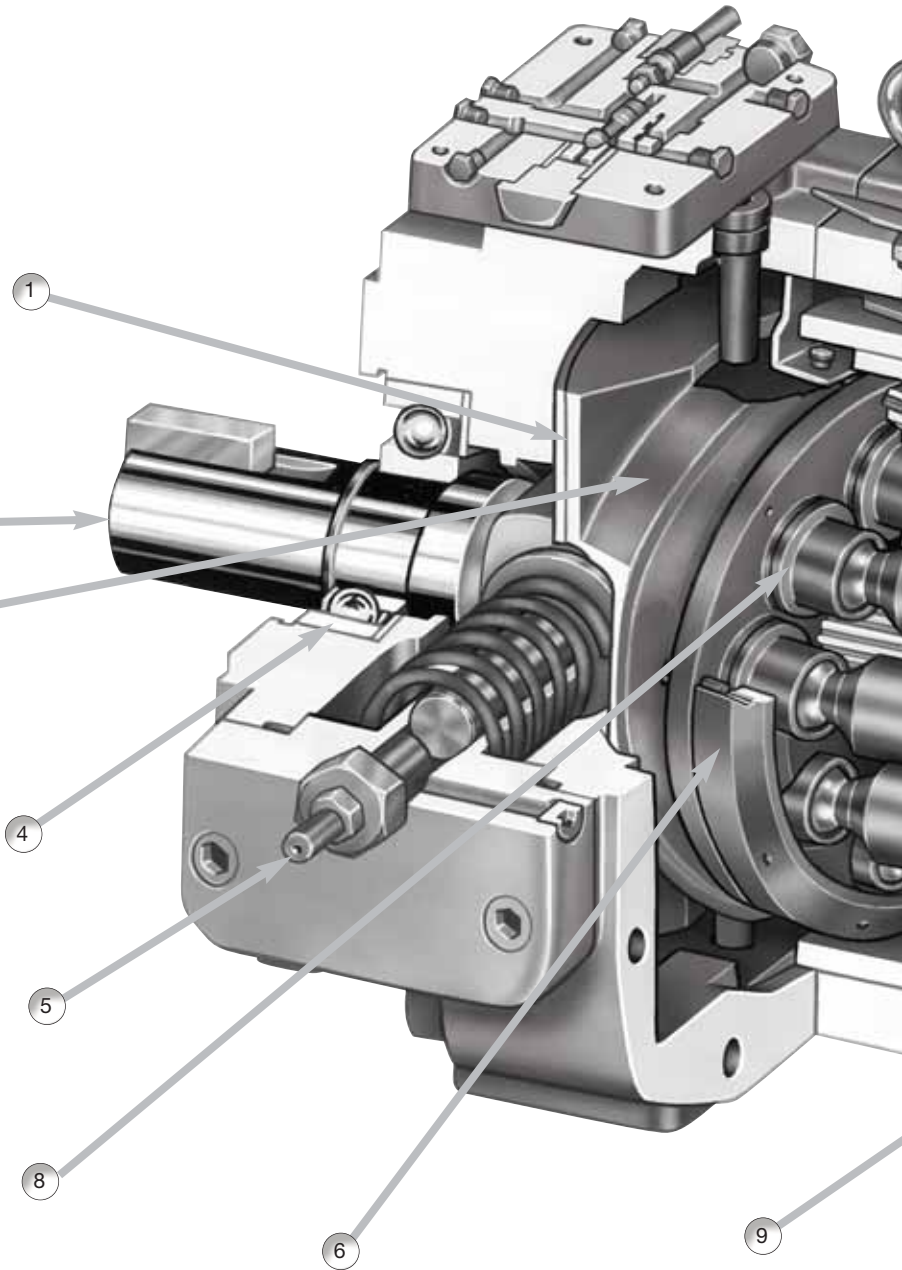

Oilgear Features and Benefits

7 Cylinder mounted polymerous journal bearings.

- Enables operation with low viscosity or other special fluids.
- Provides infinite bearing life.
- Enables compact design.

10 Rugged cylinder design.

- Hardened nodular iron construction for improved performance and contamination resistance.

12 Thru-shaft availability.

- Thru-shaft torque capability.
- Enables multiple pump installation from a single shaft.

11 Valve plate selection.

- Rear or top and bottom port connections available.

13 Quiet port plate design.

- Minimizes noise at typical electric motor speeds.

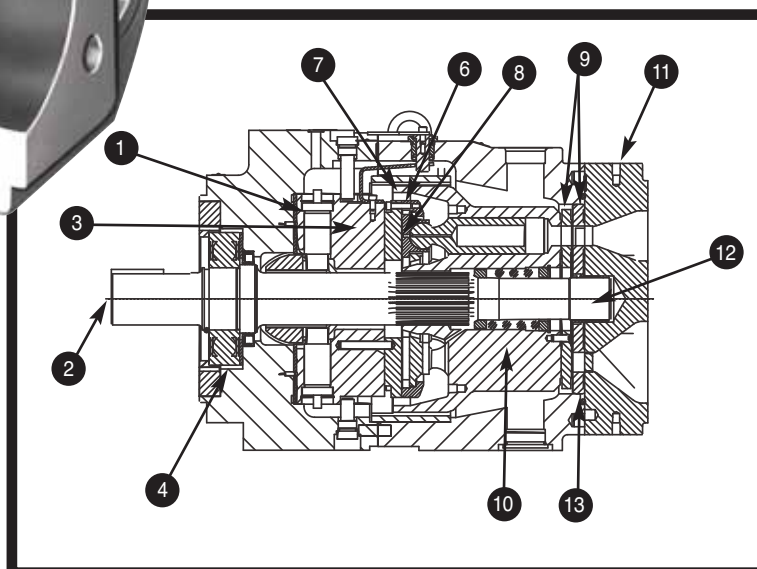

SPECIFICATIONS

80-550 SSU VISCOSITY FLUID

UNIT SIZE	THEORETICAL MAXIMUM DISPLACEMENT		RATED CONTINUOUS PRESSURE		PEAK PRESSURE		RATED FLOW AT CONTINUOUS RATED PRESSURE										MAXIMUM SPEED
							NON-SUPERCHARGED								SUPERCHARGED		
							1000 rpm		1200 rpm		1500 rpm		1800 rpm		1800 rpm		
in ³ /rev	ml/rev	psi	bar	psi	bar	gpm	lpm	gpm	lpm	gpm	lpm	gpm	lpm	gpm	lpm	rpm	
200	12.2	200	6000	414	6500	450	47	178	58	219	72	273	86	326	86	326	1800
250	15.26	250	5000	345	5800	400	59	223	72	273	91	344	109	413	109	413	1800
440	26.90	440	6500	450	7250	500	104	394	125	473	*	*	--	--	--	--	1200
540	33.00	540	5000	345	5800	400	129	488	155	587	*	*	--	--	--	--	1200

* Consult Oilgear Technical Sales Department.

NOTE: PVV-440 is supercharged only (2-8 bar).

UNIT SIZE	POWER INPUT AT CONTINUOUS RATED PRESSURE							
	1000 rpm		1200 rpm		1500 rpm		1800 rpm	
	hp	kw	hp	kw	hp	kw	hp	kw
200	185	138	223	166	278	208	330	246
250	203	152	242	180	302	225	362	270
440	489	365	587	438	*	*	--	--
540	460	343	547	408	*	*	--	--

* Consult Oilgear Technical Sales Department.

DIMENSIONS AND WEIGHTS W/O CONTROLS

UNIT	WIDTH		LENGTH		HEIGHT		WEIGHT		FACE MTG. FLANGE
	in.	mm.	in.	mm.	in.	mm.	lbs.	Kg.	
PVV200 & 250	16.31	414,3	17.14	435,4	12.01	305,1	355	161	ISO 200 4-Bolt or SAE E
PVV440 & 540	21.11	536,2	20.93	531,6	15.40	391,2	735	333	ISO 250 4-Bolt

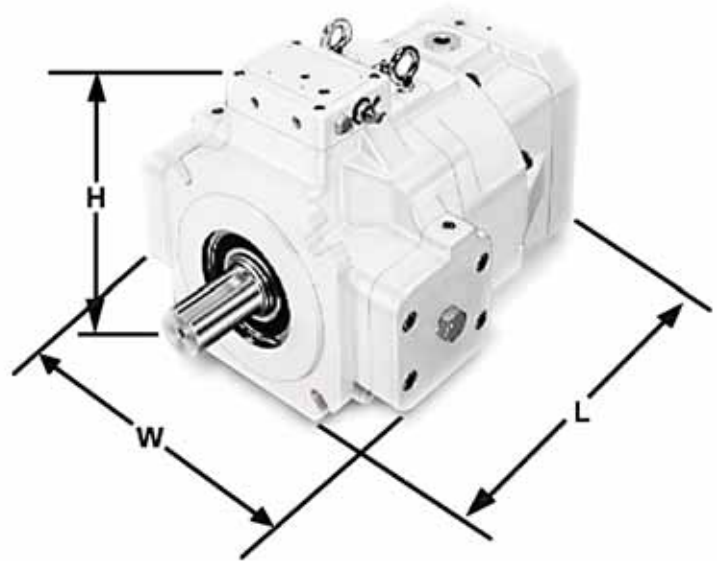

Pump Controls*

PRESSURE*

■ Single Pressure Compensator "P-1NN"

Ensures maximum pump flow until unit reaches preset control setting then regulates output flow to match the requirements of the system while maintaining preset output pressure.

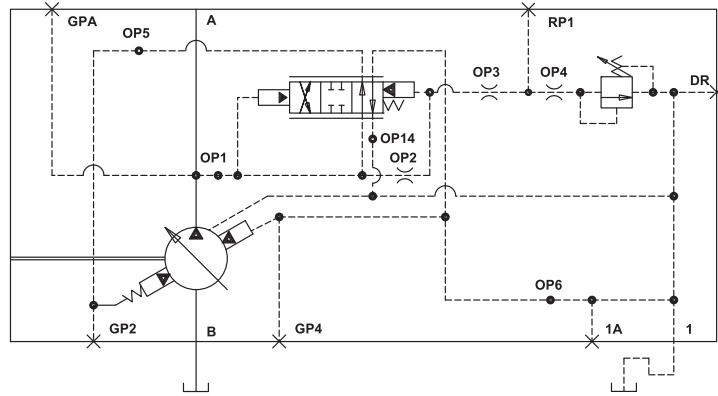

■ Single Pressure Compensator w/Load Sense "P-1NN/F"

Maintains a constant flow rate for a given flow control valve setting regardless of changes in drive speed and/or working pressure.

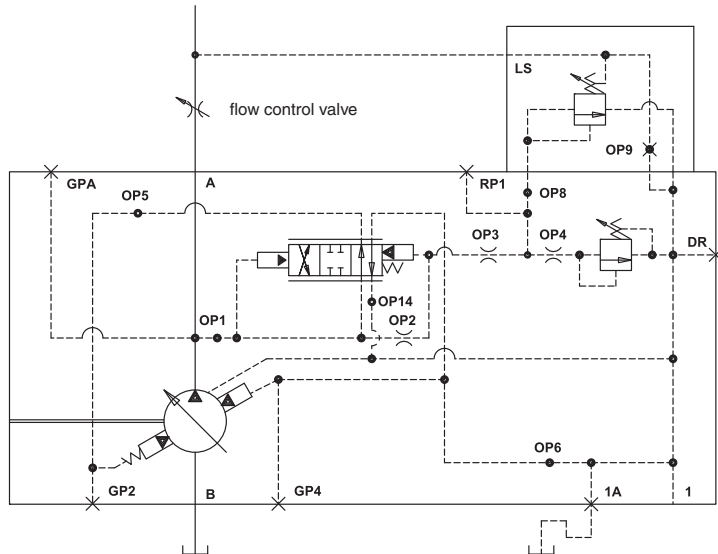

* Be sure system and pumps are protected against over loads with a high pressure relief valve. If control shifts faster than 150 m/seconds, cavitation can occur.

Not to be used for decompressing system.

** PVV-440 only available with F, VR, RU and VM controls.

PRESSURE*

Single Pressure Compensator "P-1NN/H" w/Horsepower Limit

To limit horsepower consumption, pump delivery is automatically reduced as unit pressure rises.

Refer to note in "How to Order" prior to specifying input horsepower.

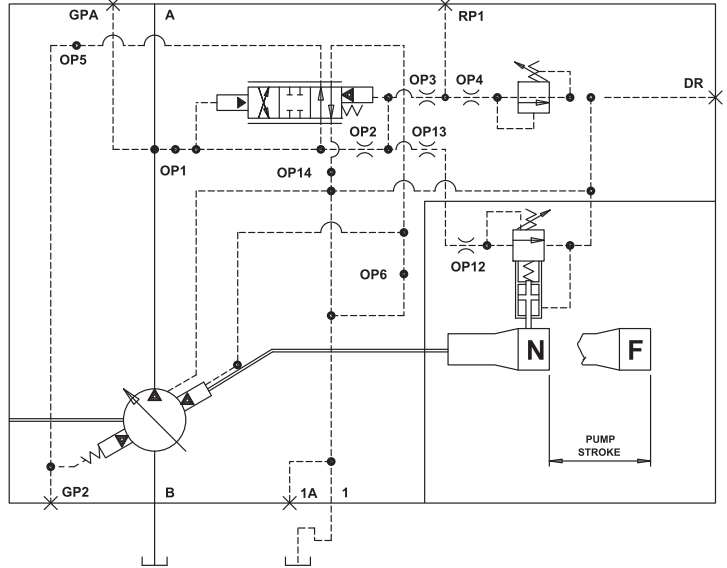

Single Pressure Compensator "P-1NN/G" w/Horsepower Limit & Load Sense

Load sensing control matches pump flow and pressure to load demand until (limited) horsepower setting is reached. Control then automatically reduces pump delivery as system pressure rises to limit horsepower consumption.

Refer to note in "How to Order" prior to specifying input horsepower.

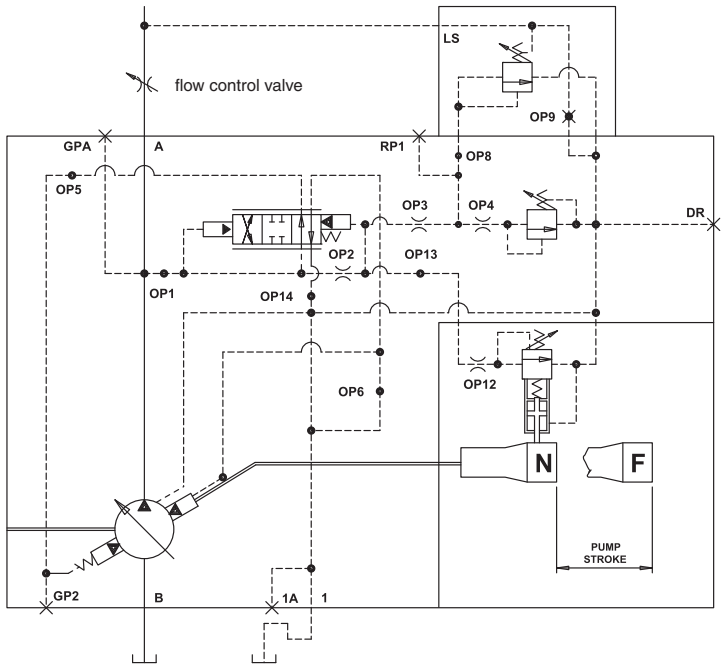

- * Be sure system and pumps are protected against over loads with a high pressure relief valve. If control shifts faster than 150 m/seconds, cavitation can occur.
- # Not to be used for decompressing system.
- ** PVV-440 only available with F, VR, RU and VM controls.

Single Soft Start Pressure Compensator#

“P-C--”

Pump starts “softly” by going quickly at low pressure to a reduced flow setting, thereby reducing start-up torque requirements. After start-up, the pressure compensator function takes over.

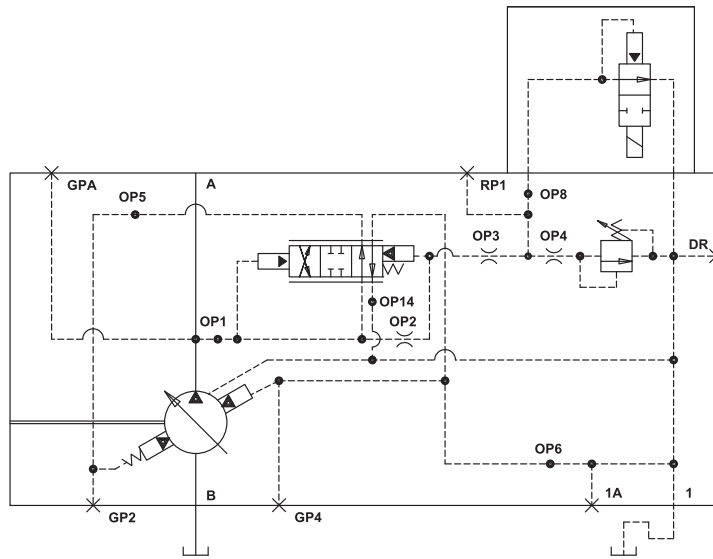

Single Soft Start w/Load Sense#

“P-C--/F”

Pump starts “softly” by going quickly at low pressure to a reduced flow setting, before maintaining a constant flow rate for a given flow control valve setting regardless of changes in drive speed and/or working pressure.

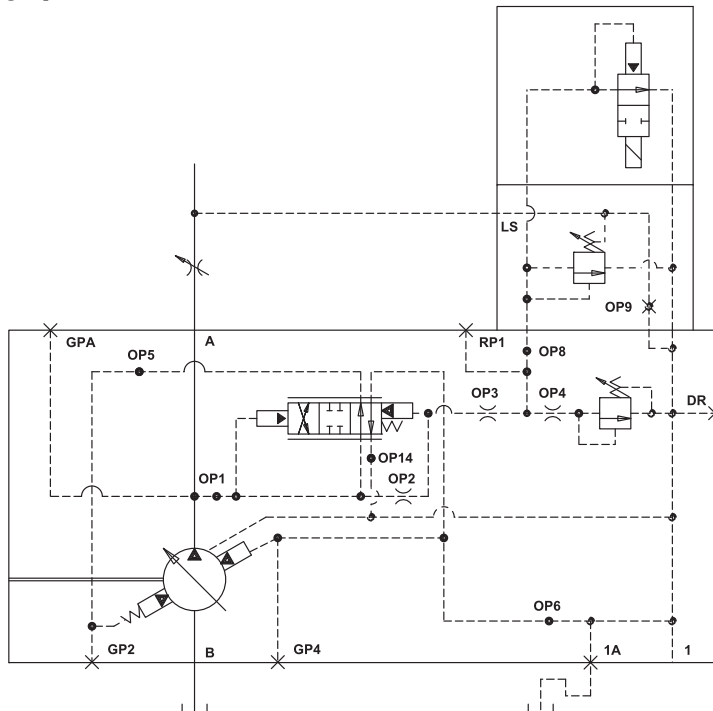

* Be sure system and pumps are protected against over loads with a high pressure relief valve.

If control shifts delivery faster than in 150 m/seconds, cavitation can occur to some degree.

Not to be used for decompressing system.

** PVV-440 only available with F, VR, RU and VM controls.

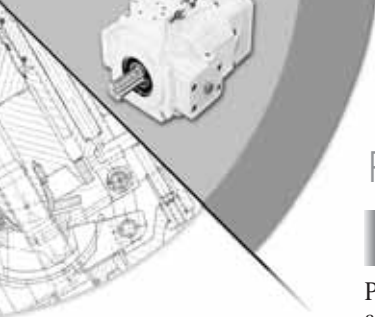

PRESSURE*

Single Soft Start w/Horsepower Limit# "P-C--/H"

Pump starts "softly" by going quickly at low pressure to a reduced flow setting, thereby reducing start-up torque requirements, before automatically reducing pump delivery as unit pressure rises and limiting horsepower consumption.

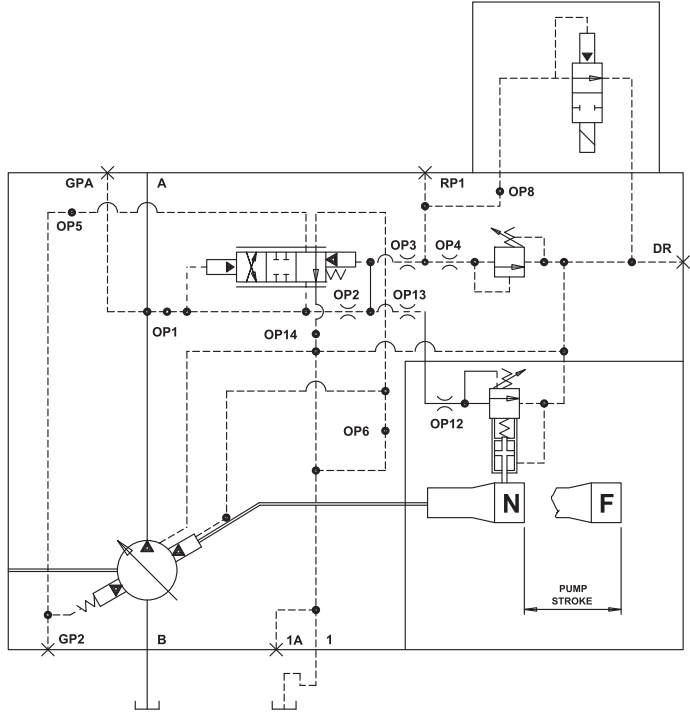

Single Soft Start w/Horsepower Limit & Load Sense# "P-C--/G"

Pump starts "softly" by going quickly at low pressure to a reduced flow setting, thereby reducing start-up torque requirements before load sensing control matches flow and pressure to load demand until (limit) horsepower setting is reached. Control then automatically reduces pump delivery as system pressure rises to limit horsepower consumption.

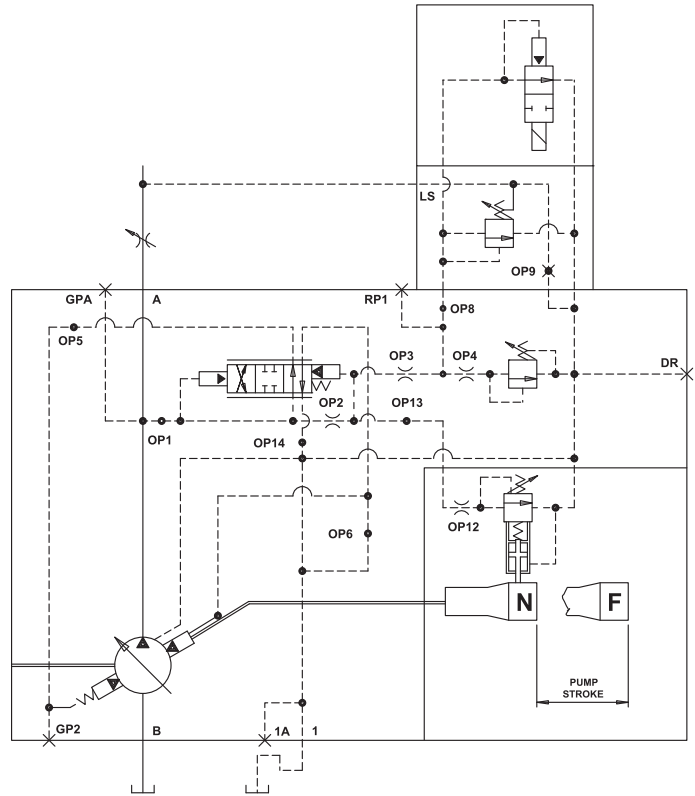

* Be sure system and pumps are protected against over loads with a high pressure relief valve.

If control shifts delivery faster than in 150 m/seconds, cavitation can occur to some degree.

Not to be used for decompressing system.

** PVV-440 only available with F, VR, RU and VM controls.

■ Dual Pressure Compensator “P-2--”

Similar to “P-1NN” but provides two independently adjustable pressure compensated deliveries as selected by an integral solenoid.

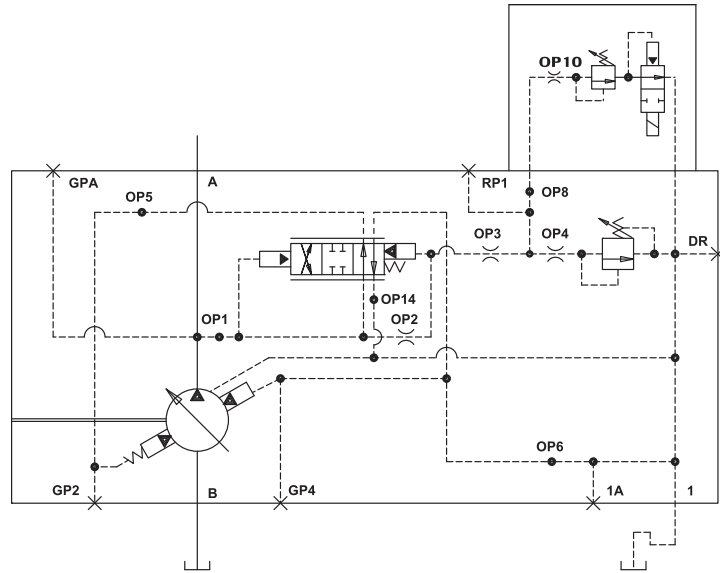

■ Triple Pressure Compensator “P-3--”

Similar to “P-1NN” but, provides three independently adjustable pressure compensated deliveries as selected by integral solenoids.

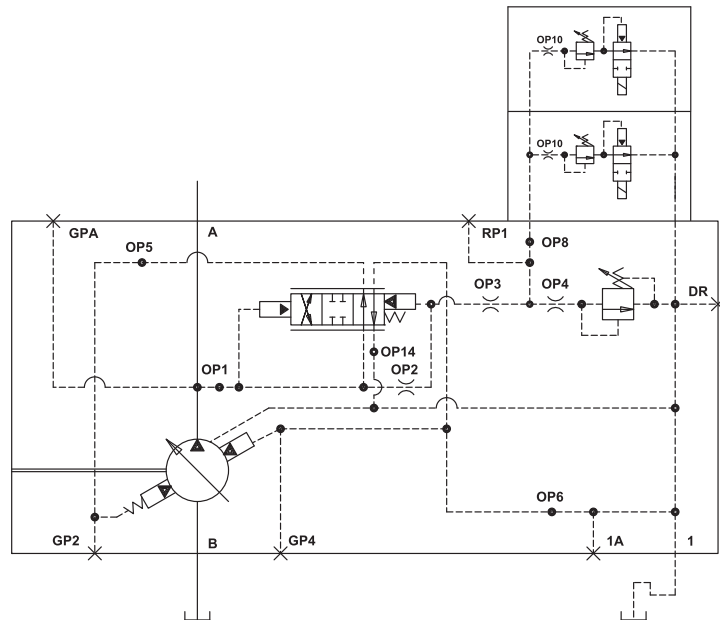

* Be sure system and pumps are protected against over loads with a high pressure relief valve.

Not to be used for decompressing system.

** PVV-440 only available with F, VR, RU and VM controls.

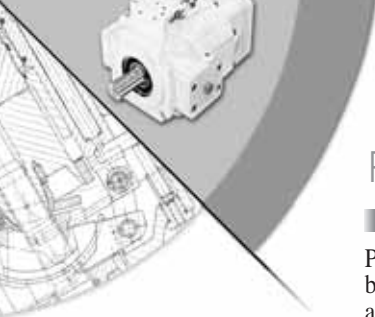

PRESSURE*

■ Dual Soft Start# “P-D--”

Pump starts “softly” similar to “P-C--” but then provides two independently adjustable pressure compensated deliveries as selected by an integral solenoid.

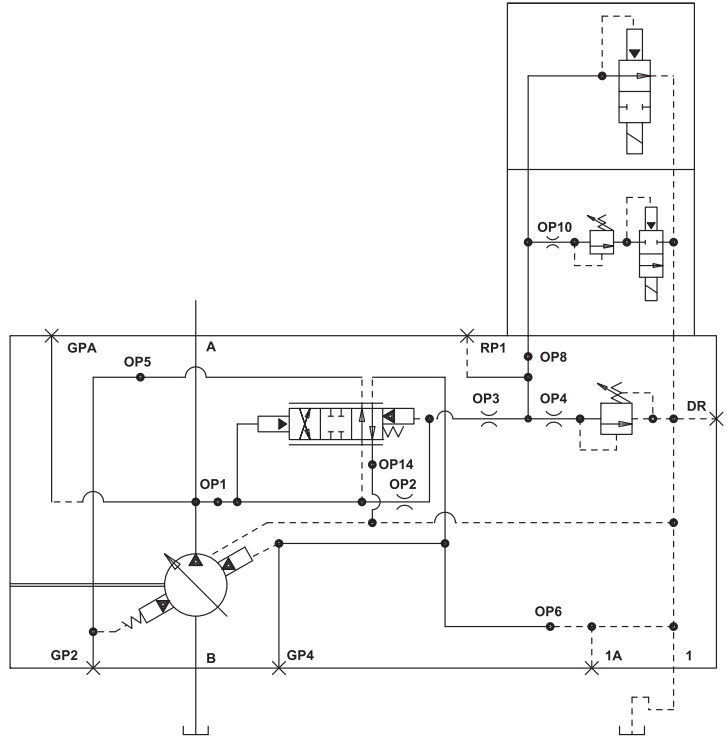

■ Triple Soft Start# “P-E--”

Similar to “P-C--” but, after the soft start the unit provides three independently adjustable pressure compensated deliveries as selected by an integral solenoid.

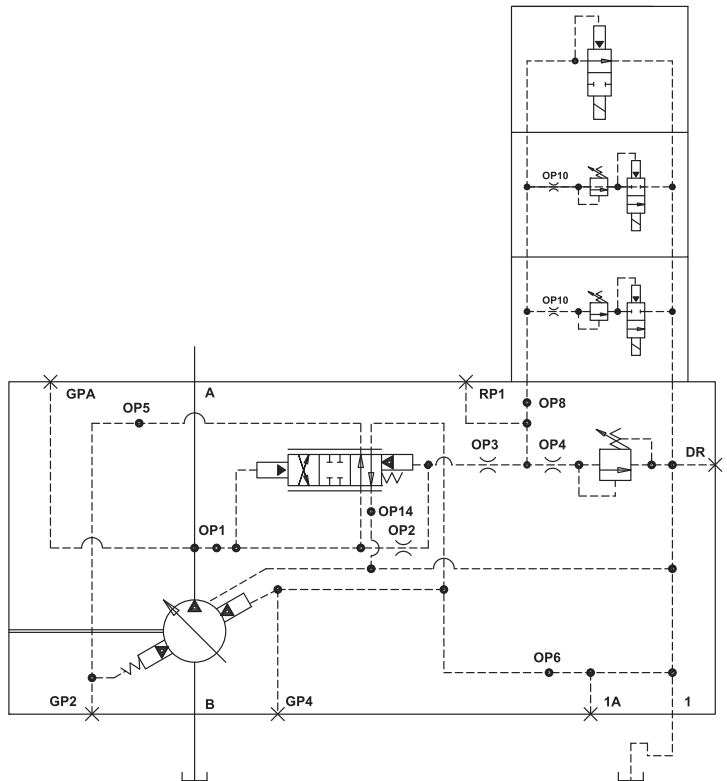

* Be sure system and pumps are protected against over loads with a high pressure relief valve.

Not to be used for decompressing system.

** PVV-440 only available with F, VR, RU and VM controls.

Electronic Proportional Pressure Compensator

“P-A” or “B”

Provides an infinite number of independent remotely adjustable pressure settings in response to an electronic command. Available in “-A, normally open” configuration (as shown) or in “-B, normally closed” configuration.

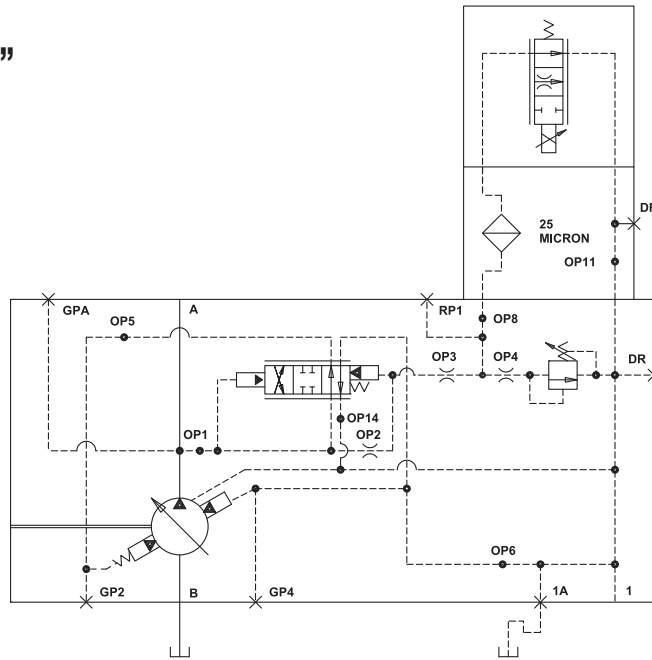

Remote Pressure Compensator “P-RNN/H” with Horsepower Limiter

A remote control module connected to this control can be used to adjust the pressure compensation setting and the horsepower limiter will automatically reduce pump delivery as unit pressure rises.

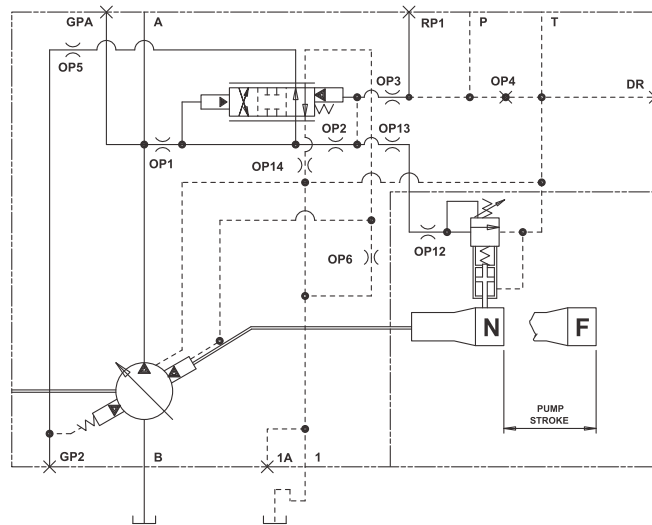

Remote Pressure Compensator “P-RNN”

A remote control module connected to this control can be used to adjust the pressure compensation setting.

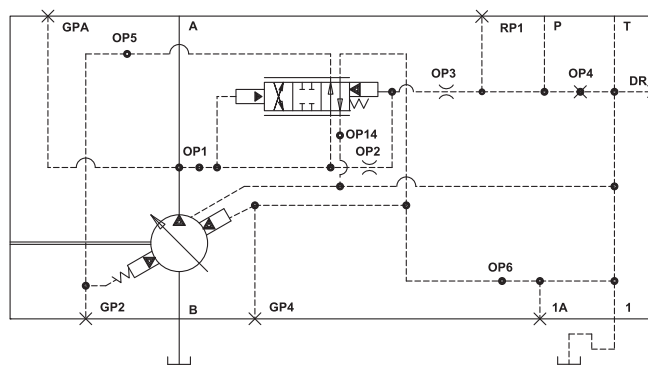

* Be sure system and pumps are protected against over loads with a high pressure relief valve.
 If control shifts delivery faster than in 150 m/seconds, cavitation can occur to some degree.
 # Not to be used for decompressing system.
 ** PVV-440 only available with F, VR, RU and VM controls.

ELECTRONIC*

Remote Electronic Servo Valve "VR"

A remote electrohydraulic servo valve can be used to position the control mechanism. Feed back from the integral LVDT can be used in an electronic closed-loop configuration to provide a highly accurate remote variable delivery control.

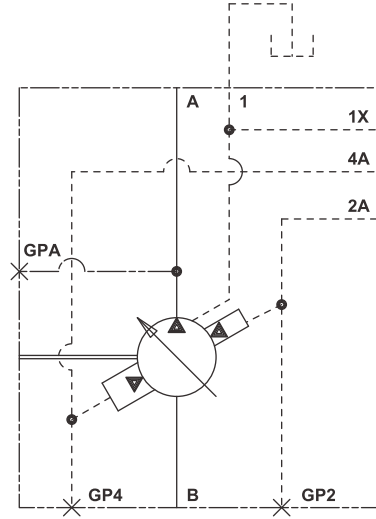

Solenoid Operated Two Volumes "RU"

Two adjustable deliveries as selected by an integral solenoid operated valve.

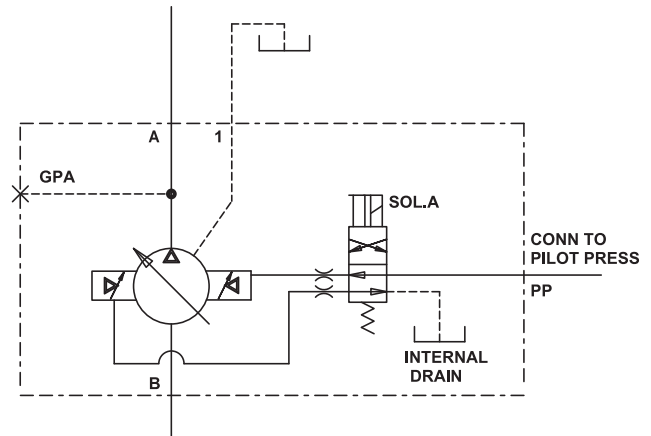

Electronic Servo Valve "VM"

An electrohydraulic servo valve positions the swashplate mechanism with a closed loop position control (with LVDT feedback) providing a highly accurate remote variable delivery control.

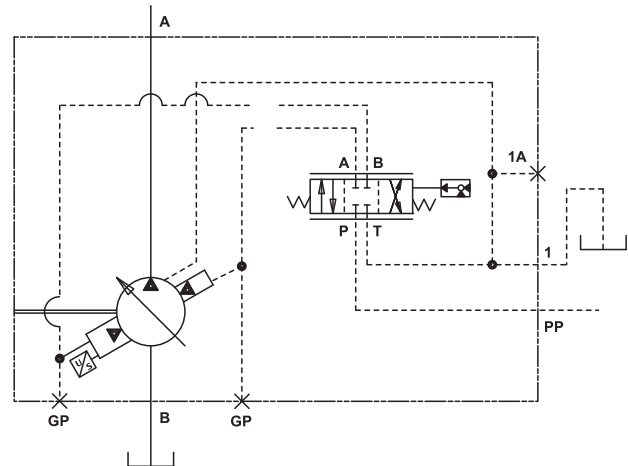

* Be sure system and pumps are protected against over loads with a high pressure relief valve.

** PVV-440 only available with F, VR, RU and VM controls.

FIXED

■ Fixed (Screw Adjustable) “F”

Two adjustable screws are used to “lock” (fix) pump delivery.

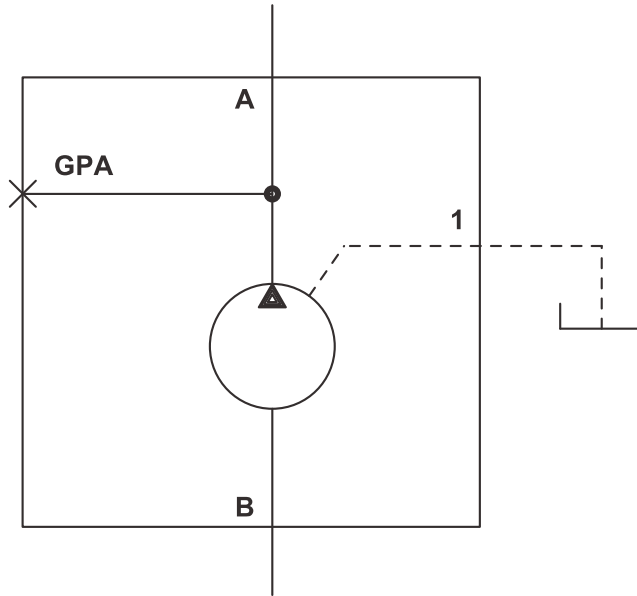

FORCE AMPLIFIER*

■ Proportional “A”

Any 5 - 15 lb force (manual, pilot pressure or “A” electrical force coil) can be applied to the stem of the amplifier valve to change the pump displacement. The control can be set up to allow either increase or decrease in stroke (delivery) with increase in force applied. For additional information on this control, varieties, use with modification horsepower limit, load sense, etc. please see Data Sheet 47428.

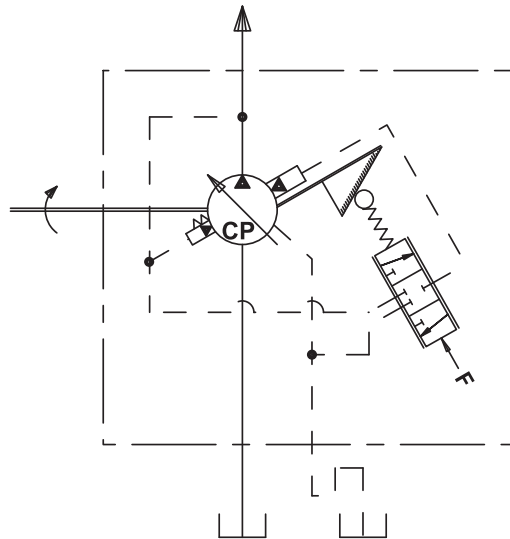

* Be sure system and pumps are protected against over loads with a high pressure relief valve.

** PVV-440 only available with F, VR, RU and VM controls.

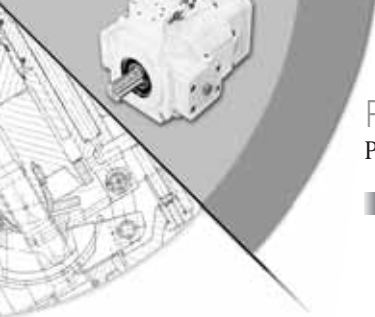

PERFORMANCE

Performance curves are based on a viscosity of 160 SSU.

■ PVV-200

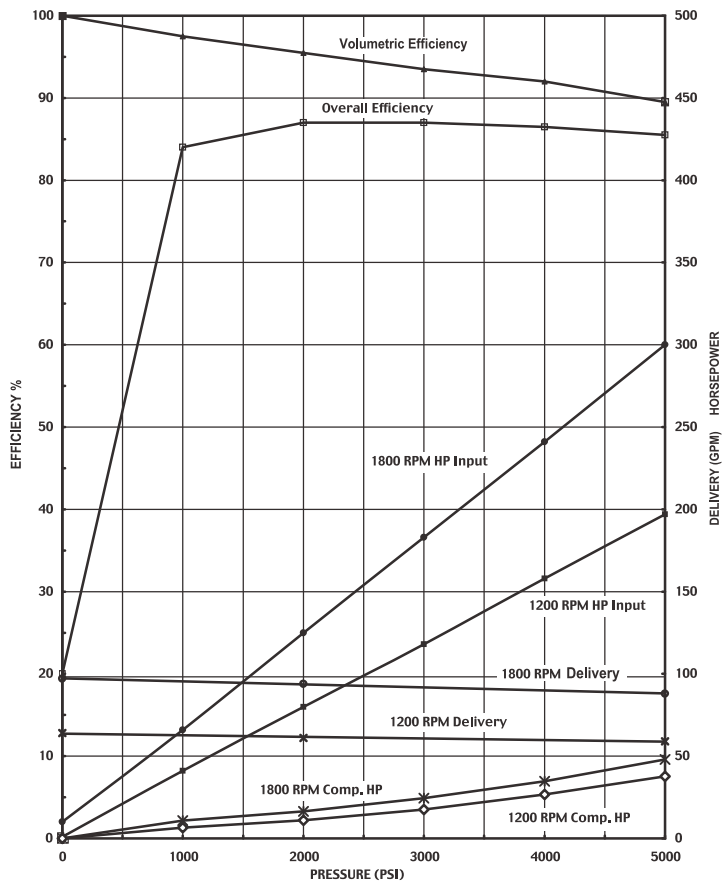

■ PVV-250

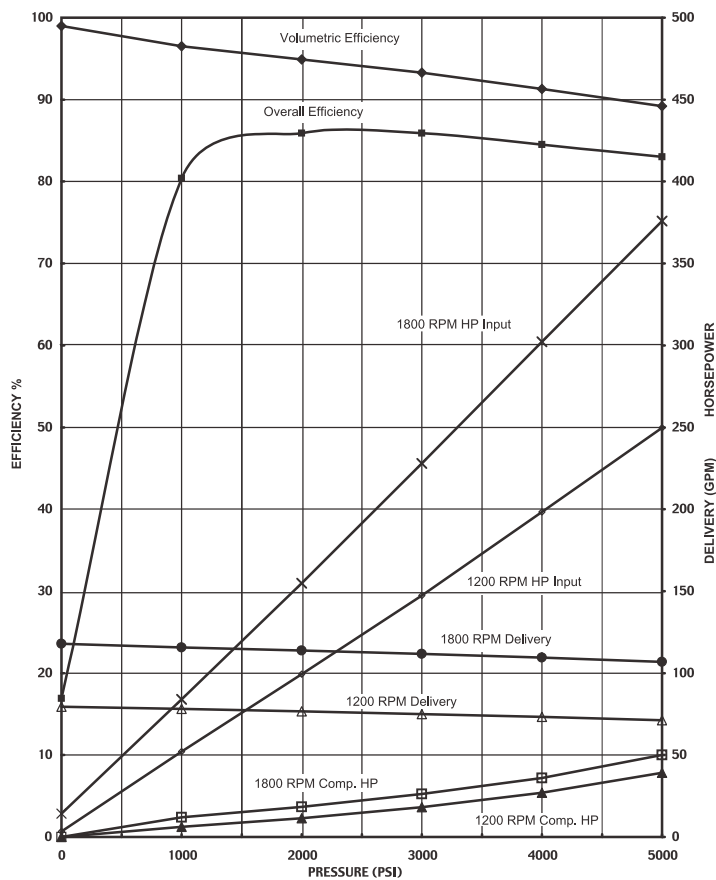

PERFORMANCE

PVV-440

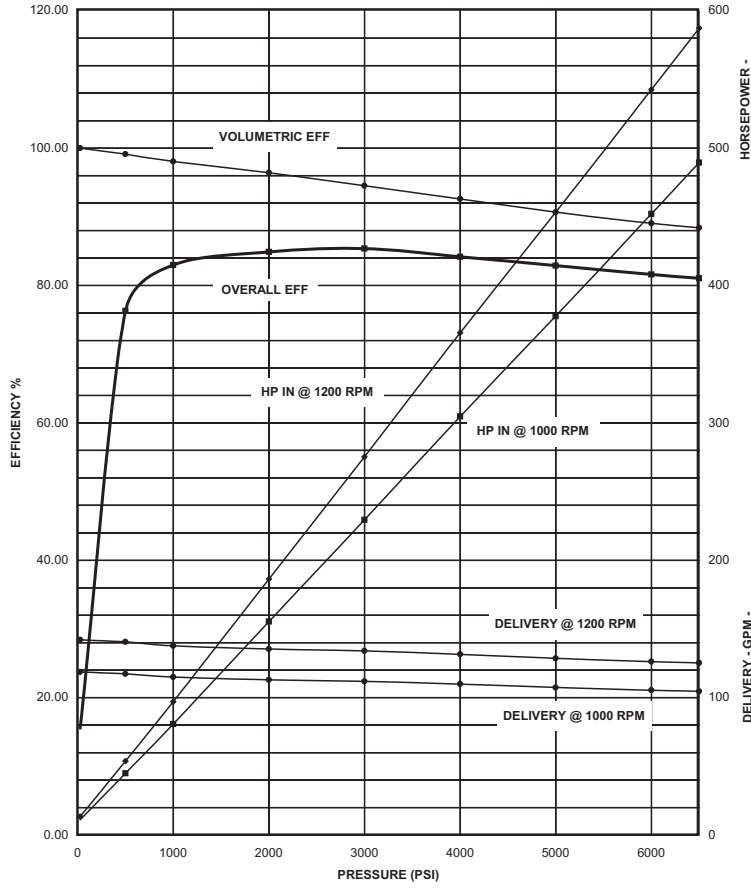

PVV-540

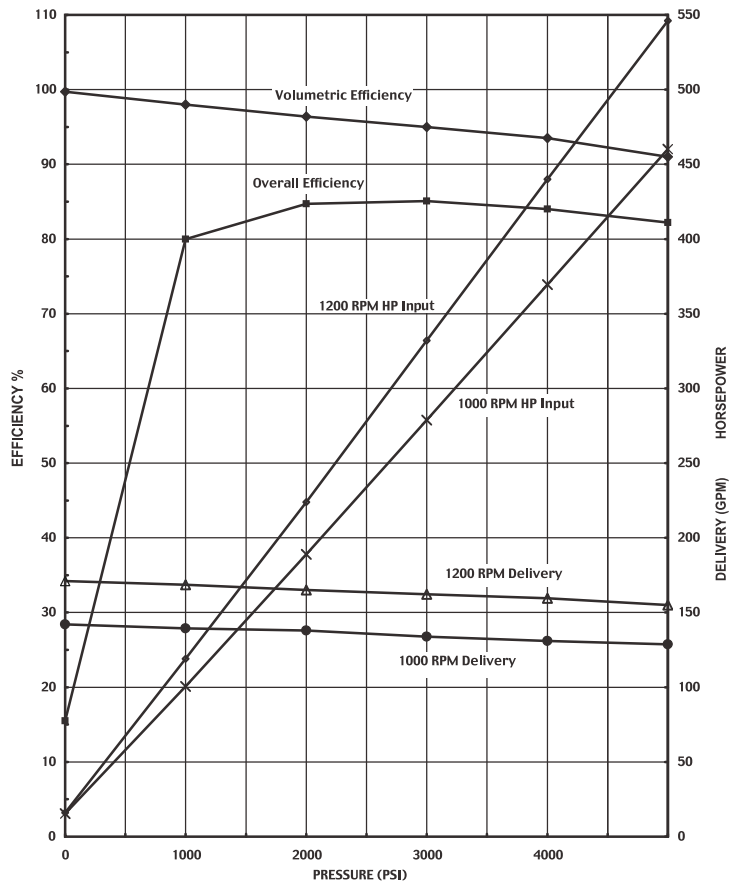

Oilgear Performance Curves

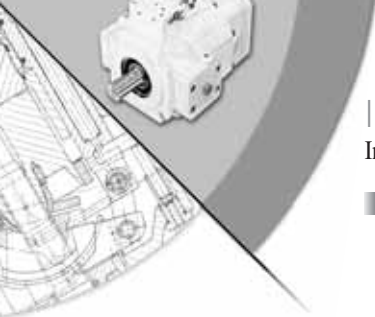

INLET SUCTION/SUPERCHARGE

Inlet/supercharge curves are based on a viscosity of 500 SSU.

■ PVV-200

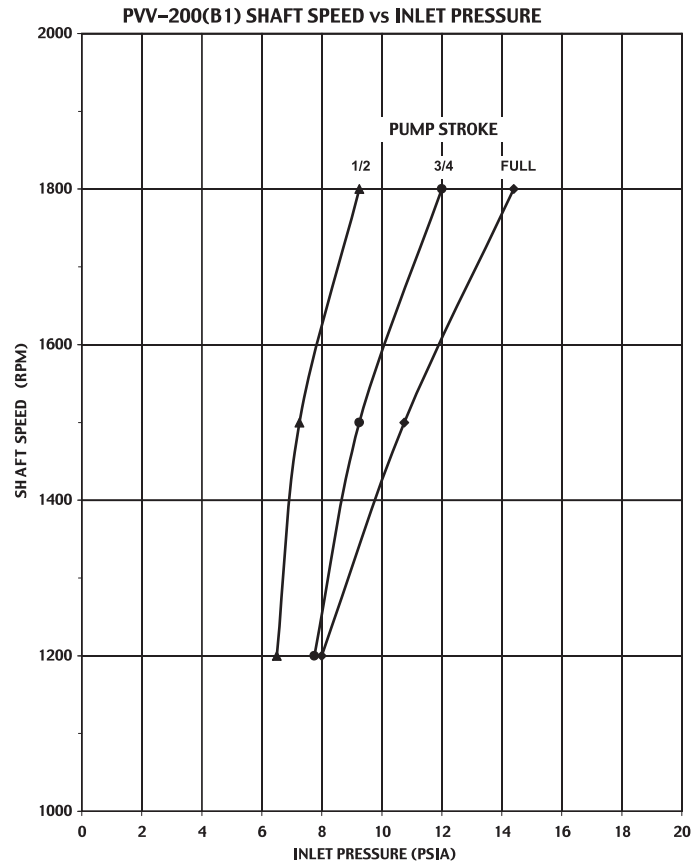

■ PVV-250

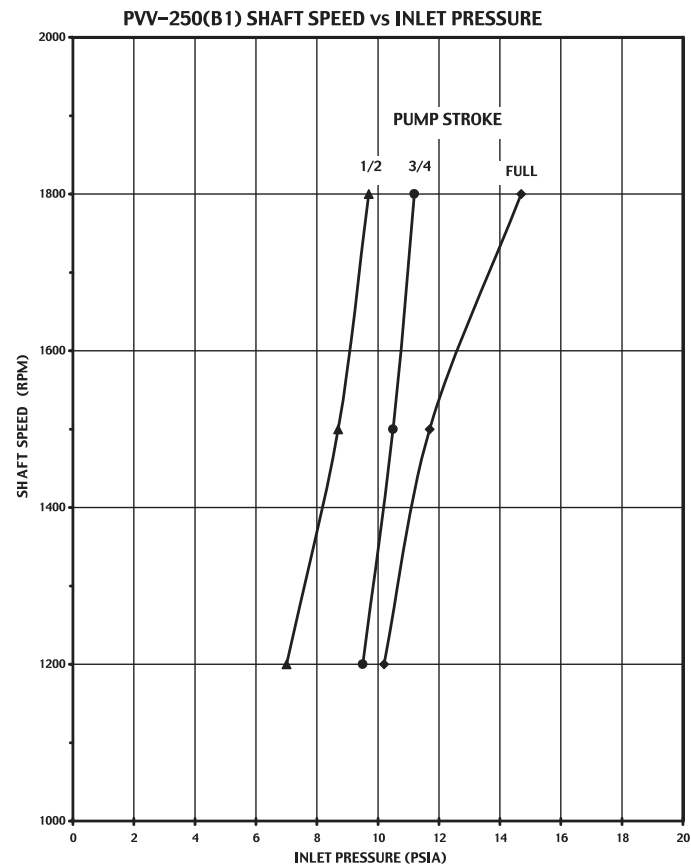

INLET SUCTION/SUPERCHARGE

■ PVV-540

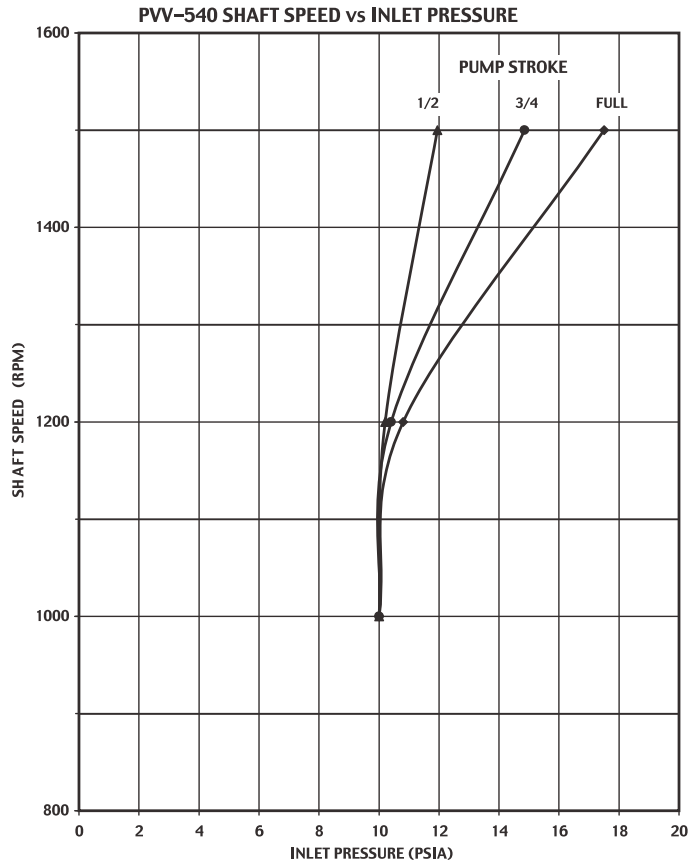

Oilgear Performance Curves

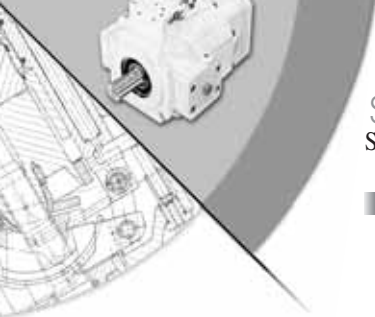

SOUND

Sound curves are based on a viscosity of 500 SSU.

■ PVV-200 or 250

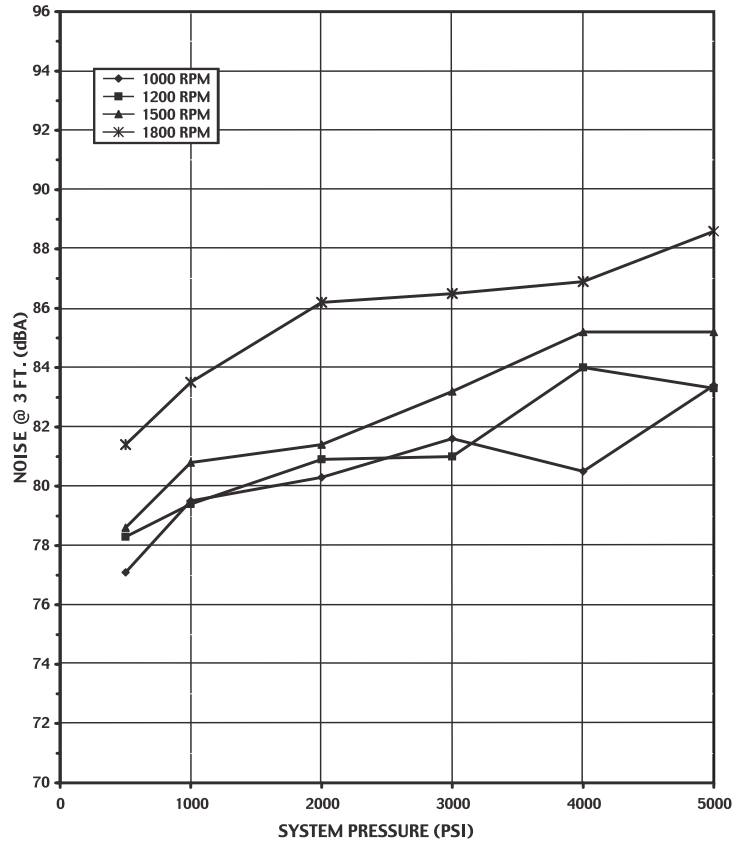

■ PVV-540 or 440

NOTE: PVV-440 must be supercharged 2-8 bar regardless of rpm.

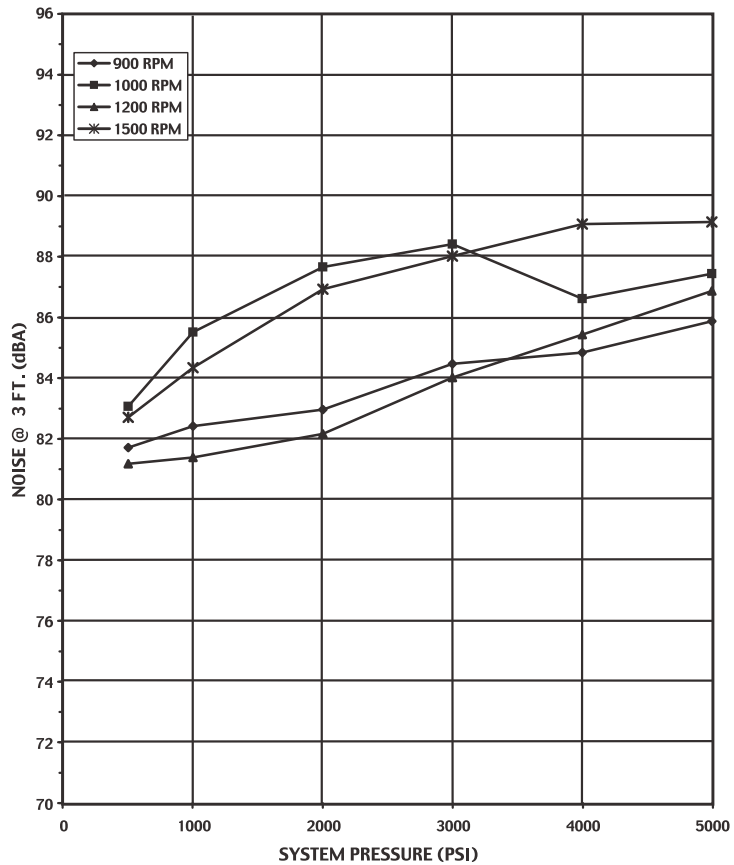

MULTIPLE PUMP COMBINATIONS

Two Oilgear “PVV” axial piston variable delivery pumps can be integrally coupled together and driven from a single shaft. The PVV200/250 can be run at 150% thru-shaft torque with the front pump at full rated output and the rear pump at half rated output, or with the front pump at half rated output and the rear pump at full rated output (or any combination that equals 150% or less). The PVV540 can be run at 50% thru-shaft torque with the front pump at full rated output and the rear PVV200/250 pump also at full rated output. Pump deliveries can be combined for large volume circuits or deliveries can be used individually. See the following table and calculations for Allowable Thru-shaft Torque.

How to calculate torque for each pump

$$T \text{ (in. lbs.)} = \frac{\text{Pressure (psi)} \times \text{Displacement (cu. in./rev.)} *}{5.655}$$

Add the respective torques for each unit:

T1 = front pump torque required

T2 = second pump torque required

Tn = Additional pump or torque for any other driven device

T1 + T2 + Tn Sum must be less than T max. shown in table

Unit Size	Max Input Shaft Torque (in-lbs)	Max Rear Pump Drive Shaft Torque (in-lbs)
200/250	20,295	13,530
440	Thru shaft not available	--
540	43,770	14,590

* Assumes 90% mechanical efficiency.

NOTE: Additional support is recommended for multiple coupled pumps used in high vibration or mobile applications.



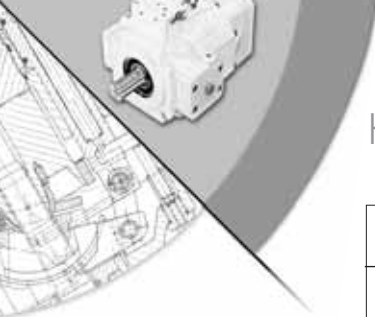

HOW TO ORDER

BLOCK NUMBER EXPLANATION	1	2	3	-	4	-	5	6	7	-	8	9	10	11	-	12	-	13	14	-	15
VARIABLE PUMP EXAMPLE	P	V	V	-	540	-	A1	U	V	-	L	D	F	Y	-	P	-	1NN	SN	-	NN

- 1 = UNIT**
P = Pump
- 2 = TYPE**
V = Variable
- 3 = DESIGN TYPE**
V = Type
- 4 = UNIT SIZE**
200= 200 ml/rev.
250= 250 ml/rev.
440= 440 ml/rev.
540= 540 ml/rev.
- 5 = DESIGN SERIES**
*B1= Series (Subject to change)
A2= 440
- 6 = DESIGN SERIES MODIFIER**
A = SAE Mounting and BSPP Ports
(200/250 only)
B = ISO Mounting and BSPP Ports
S = SAE Mounting and SAE Ports
(200/250 only)
U = ISO Mounting and SAE Ports (not available with 440)
- 7 = SEALS**
V = Viton (Std.)
B = Buna-N
E = Butyl
P = EPR
- 8 = ROTATION**
L = Left-hand (CCW) (Std.)
R = Right-hand (CW)
- 9 = VALVE PLATE TYPE**
D = Top & Bottom Ported
(One-way Service) (not available with 440)
S = Rear Ported (One-way Service)
- 10 = CONNECTION TYPE**
F = Flange (Flanges are customer supplied)
- 11 = SHAFT END DESIGNATOR**
Y = Keyed (ISO) (Std.)
S = Splined (SAE)
T = Keyed (SAE)
- 12 = CONTROL TYPE**
A = Force Amplifier (not available with 440)
F = Fixed (screw adjustable)
P = Pressure Compensating (not available with 440)
R = Two Position Solenoid Selector
V = Electrohydraulic (w/Feedback)

13= CONTROL MODIFIER

13						
a	b	c	/	d	e	f

Omit if not required

"A" CONTROL ONLY

13a = OPERATOR

- E= Proportional Coil Amplifier Connector (Open Loop)
- F= Proportional Coil Operator with Amplifier Connector and D.C.D.T. (Closed Loop)
- R= Remote Pressure Signal 150 to 650 PSI (10 to 45 Bar)
- P = Pull Type Manual Stem Operator
- M= Push Type Manual Stem Operator

13b = SIGNAL OUTPUT

- R= Rising Signal/Increases Stroke
- F = Falling Signal/Increases Stroke

13c = CONTROL BIAS

- F = Spring Bias to Full Stroke (Std.)
- G= With Sequence Valve for Standby Pilot
- H= Ext. Pilot Pressure Port w/Checks

13d = UNIT

- P = Pressure Over-ride Modifiers

13e= PRESSURE OVER-RIDE OPTIONS

- F = Single Setting Flange Mount With System Safety
- G = Multi Compensator or System Relief Settings Via Pilot Control Module; Flange Mount

13f = INPUT HORSEPOWER OVER-RIDE

- H=100 = 100 HP Input (Specify 1800 RPM HP)

"F" CONTROL ONLY

13abc = STROKE

- 100 = Full Stroke
- 075 = 75% Stroke
- 050 = 50% Stroke
- etc.

* Subject to change without notice.

HOW TO ORDER

BLOCK NUMBER EXPLANATION	1	2	3	-	4	-	5	6	7	-	8	9	10	11	-	12	-	13	14	-	15
VARIABLE PUMP EXAMPLE	P	V	V	-	540	-	A1	U	V	-	L	D	F	Y	-	P	-	1NN	SN	-	NN

"P" CONTROL ONLY

13a = COMPENSATOR OPTIONS

- 1 = Single Setting
- 2 = Dual Setting
- 3 = Triple Setting
- A = Normally Open Proportional Device
- B = Normally Closed Proportional Device
- C = Single Pressure w/Soft Start
- D = Dual Pressure w/Soft Start
- E = Triple Pressure w/Soft Start
- R = Remote Control

13b = SOLENOID VOLTAGE

- N = None Required
- 0 = 115/60 - 110/50 VAC
- 1 = 230/60 - 220/50 VAC
- 2 = 12 VDC
- 3 = 24 VDC

13c = CONNECTOR

- N = None Required
- R = .500 NPT w/o Lite
- W = .500 NPT w/Lite
- S = PG-11 w/o Lite
- L = PG-11 w/ Lite

13d = CONTROL MODIFIER

- F = Load Sense Option
- G = Load Sense w/Horsepower Limiting Option (200/250 only)
- H = Horsepower Limiting Option (200/250 only)

13e = INPUT HORSEPOWER

- 100 = 100 HP Input
- (Specify 1800 RPM HP)

"R" CONTROL ONLY

13a = TYPE

- U = Two Volume Control

13b = SOLENOID VOLTAGE

- 0 = 115/60 - 110/50 VAC
- 1 = 230/60 - 220/50 VAC
- 2 = 12 VDC
- 3 = 24 VDC

13c = CONNECTOR

- N = None
- R = .500 NPT w/o Lite
- W = .500 NPT w/Lite
- S = PG-11 w/o Lite
- L = PG-11 w/Lite
- B = .500 NPT Conduit Box

"V" CONTROL ONLY

13a = TYPE

- M20 = Integral 20 Liter SV
- R = Remote Mounted SV

13b = (REMOTE ONLY) PUMP MOUNTING

- N = Outside of Reservoir
- T = "In-Tank" Mounting

13c = (REMOTE ONLY) VISUAL STROKE INDICATOR

- N = None
- L = Cable Mounting Arranged For Indicator on Left Side of Pump, Facing Driveshaft
- R = Cable Mounting Arranged For Indicator on Right Side of Pump, Facing Driveshaft.

13d = (INTEGRAL SV ONLY) CONTAMINATION FUSE

- F = Fuse Included

14 = VOLUME STOPS

- SN = Maximum
- SA = Minimum
- SB = Max. & Min.

15 = COVER PLATE (not available with 440)

- NN = None
- CP = Cover Plate

ADAPTER (If Used) (not available with 440)

- AN = SAE A; 2 Bolt Mounting (200/250 only)
- AA = SAE AA; 2 Bolt Mounting (200/250 only)
- BN = SAE B; 2 Bolt Mounting
- BB = SAE BB; 2 Bolt Mounting (200/250 only)
- CN = SAE C; 2 Bolt Mounting

(Omit If Not Required)

Oilgear How to Order

Oilgear

World Headquarters
The Oilgear Company

2300 South 51st Street Milwaukee, WI USA 53219
phone: 414/327-1700 fax: 414/327-0532

www.oilgear.com

For more information about your application or the products
in this brochure, please contact your nearest Oilgear facility.



BRAZIL
Oilgeardo Brazil Hydraulica Ltd.

CANADA
The Oilgear Company

FRANCE
Oilgear Towler S.A.

GERMANY
Oilgear Towler GmbH

INDIA
Oilgear Towler Polyhydron Pvt. Ltd.
Towler Automation Pvt. Ltd.

ITALY
Oilgear Towler S.r.l.

JAPAN
The Oilgear Japan Company

KOREA
Oilgear Towler Korea Co. Ltd.

MEXICO
Oilgear Mexicana S.A. de C.V.

SPAIN
Oilgear Towler S.A.

TAIWAN
Oilgear Towler Taiwan Co. Ltd.

UNITED KINGDOM
Oilgear Towler Ltd.

UNITED STATES OF AMERICA
The Oilgear Company
Olmsted Products

