

NOTES:

1. PUMPS DESIGNED FOR ONE-WAY SERVICE AND ARE DIMENSIONED AS SHOWN.
2. THESE UNITS ARE DESIGNED TO RUN CASE FULL OF FLUID AT ALL TIMES. FILL CASE BEFORE STARTING AND CONNECT DRAIN LINES ACCORDINGLY.
3. NUMERICAL DIMENSIONS GIVEN IN INCHES/[MM].
4. NET WEIGHT- 127 LBS [56 KG] FOR VERSION SHOWN
130 LBS [57 KG] FOR SIDE PORT VALVE PLATE
137 LBS [62 KG] FOR THRU SHAFT VERSION.

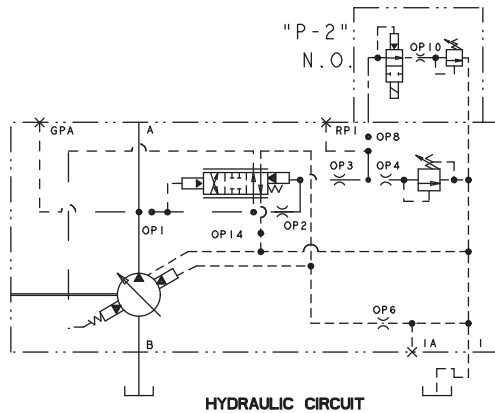

LIFTING HOLE
.375-16UNC-2B

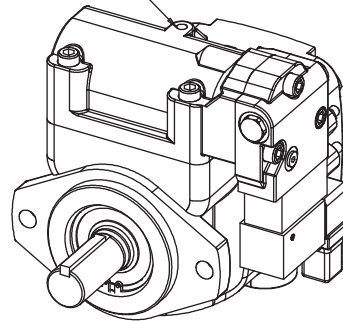

OPTIONAL MAXIMUM VOLUME STOP
.250" [6.3 mm] INTERNAL HEX
1 TURN CW DECREASES DELIVERY 7%
RANGE: 100% TO 0%
FACTORY SET TO MAXIMUM VOLUME
UNLESS SPECIFIED OTHERWISE.

LOW PRESSURE COMPENSATOR ADJUSTMENT
.188" [4.8 mm] INTERNAL HEX
1 TURN CW INCREASES PRESSURE SETTING 1000 PSI.
RANGE: 300 TO 3750 PSI (130) 5000 PSI (100)

HIGH PRESSURE COMPENSATOR ADJUSTMENT
.188" [4.8 mm] INTERNAL HEX
1 TURN CW INCREASES PRESSURE SETTING 1000 PSI.
RANGE: 300 TO 3750 PSI (130) 5000 PSI (100)

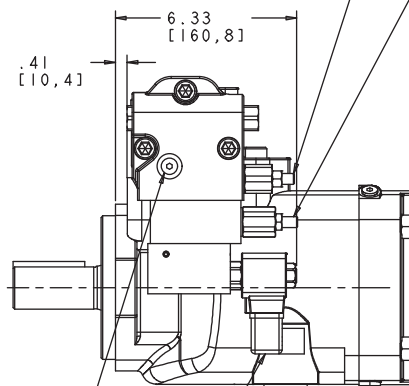
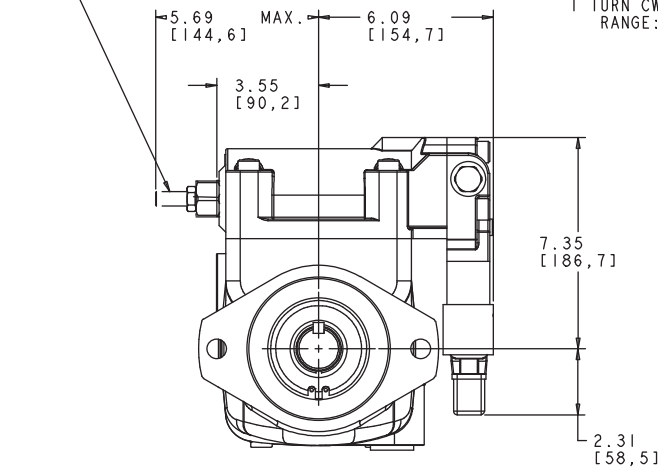

REMOTE PORT RPI-
#4 SAE STR. THD.
(PLUGGED)
(.438-20UNF-2B THD.)

PRESSURE SELECTOR SOLENOID
DIN 43650 ELECTRICAL CONN

FOR BASIC PUMP DIMENSIONS
SEE PLANOGRAPHS:
DS-47942 DS-47943 DS-47944