

**Installation Drawing**

**Manual Handwheel Control (B Frame)**

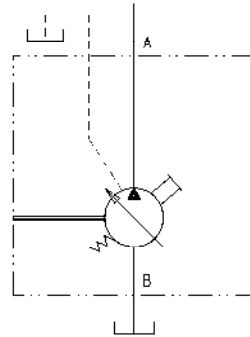

**HYDRAULIC CIRCUIT  
PUMP WITH M-H CONTROL**

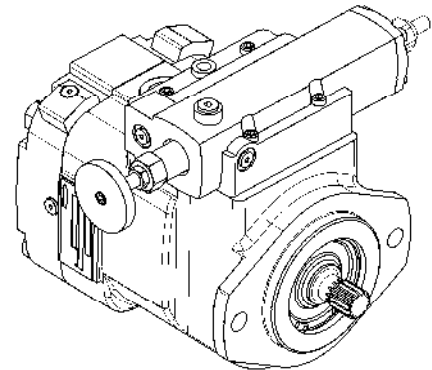
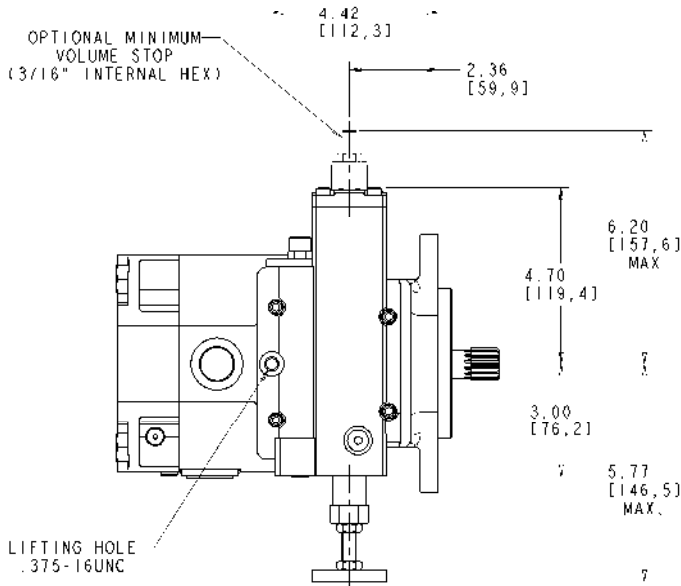

CLOCKWISE ROTATION OF HANDWHEEL DECREASES PUMP FLOW.  
COUNTERCLOCKWISE ROTATION INCREASES PUMP FLOW.  
NEUTRAL TO FULL STROKE REQUIRES 14.5 TURNS.

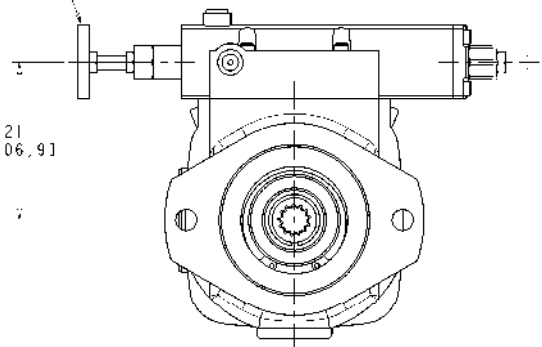
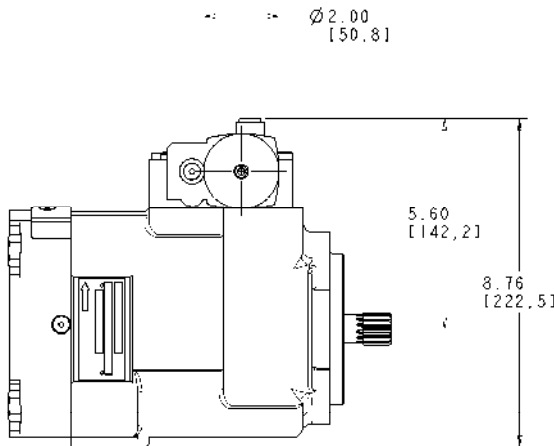

FOR BASIC PUMP DIMENSIONS SEE PLANOGRAPHS:  
DS-47483, DS-47484, DS-47485