

NOTES:

- 1) PUMP IS DESIGNED FOR ONE-WAY SERVICE ONLY, AND IS DIMENSIONED AS SHOWN.
- 2) THESE UNITS ARE DESIGNED TO RUN CASE FULL OF FLUID AT ALL TIMES. FILL CASE BEFORE STARTING AND CONNECT DRAIN LINES ACCORDINGLY.
- 3) NUMERICAL DIMENSIONS GIVEN IN INCHES/[MM].
- 4) NET WEIGHT- 58 LBS [26 KG] FOR VERSION SHOWN
64 LBS [29 KG] FOR THRU SHAFT VERSION.

M-N CONTROL

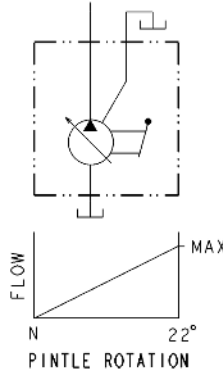

M-S CONTROL

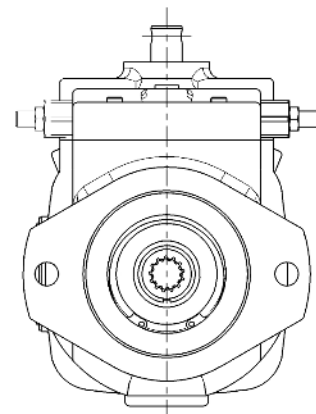
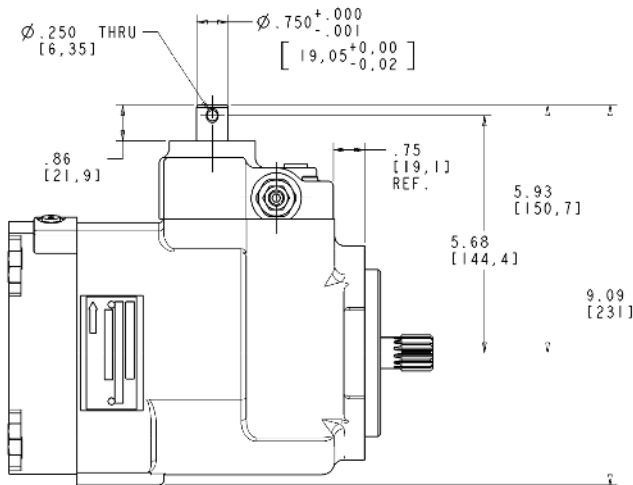
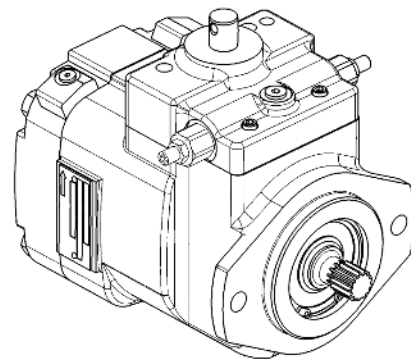
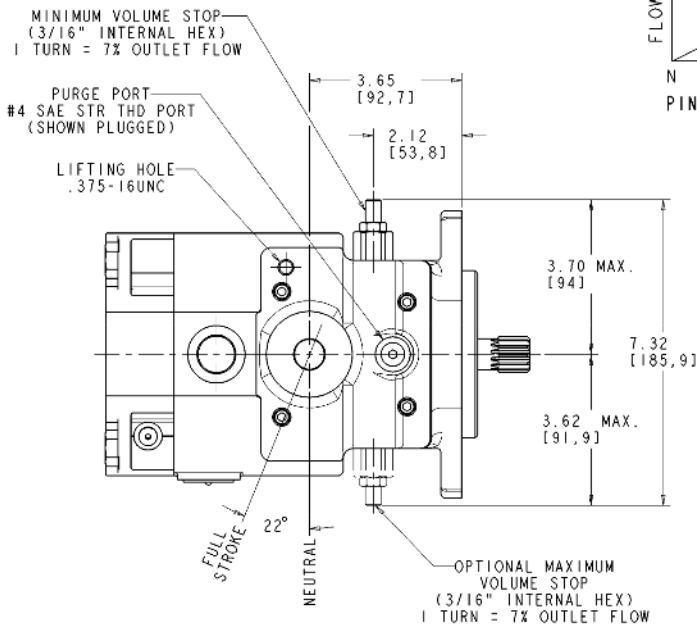
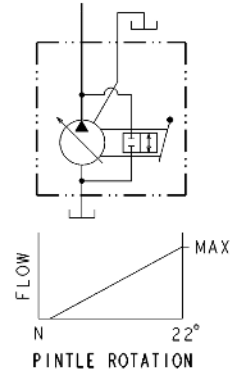

FOR BASIC PUMP DIMENSIONS SEE PLANOGRAPHS:
DS-47483, DS-47484, DS-47485

520012-211