

OILGEAR TYPE “PVG” PUMPS - 100/130 (SERIES F1U) SERVICE INSTRUCTIONS

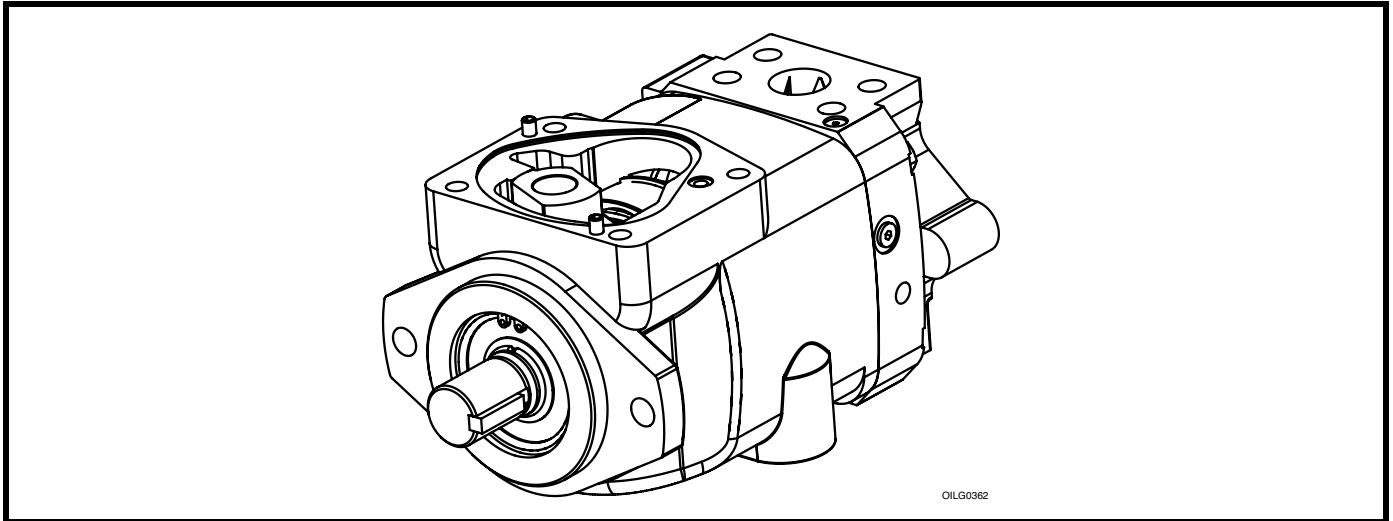

Figure 1. Typical Oilgear “PVG” Open Loop Pump

PURPOSE OF INSTRUCTION

These instructions will simplify the installation, operation, maintenance and troubleshooting of Oilgear type “PVG” pumps.

Become familiar with the construction, principle of operation and characteristics of your pump to help you attain satisfactory performance, reduce shutdown and increase the pump's service life. Some pumps have been modified from those described in this bulletin and other changes may be made without notice.

REFERENCE MATERIAL

Fluid Recommendations	Bulletin 90000
Contamination Evaluation Guide	Bulletin 90004
Filtration Recommendations	Bulletin 90007
Piping Information	Bulletin 90011
Installation of Vertically Mounted Axial Piston Units.....	Bulletin 90014
PVG Open Loop Pumps, Sales	Bulletin 910005
PVG Application Guidelines	Bulletin 847019

Pump Control Instructions, Series F1U

“P-1NN” Single Pressure Compensator	Bulletin 947551
“P-1NN/F” Single Pressure Compensator w/Load Sense	Bulletin 947552
“P-1NN/H” Single Pressure Compensator w/H.P. Limiter	Bulletin 947553
“P-1NN/G” Horsepower Limiter w/Load Sense	Bulletin 947554
“P-2NN” Dual Pressure Compensator	Bulletin 947555
“P-CNN” Single Pressure - Soft Start	Bulletin 947557
“P-CNN/H” Single Pressure - Soft Start w/H.P. Limiter	Bulletin 947558
“P-2NN/H” Dual Pressure Compensator w/H.P. Limiter.....	Bulletin 947559
“V-S25” Electro Hydraulic Servo Valve	Bulletin 947560
“V-M20” Electro Hydraulic Servo Valve	Bulletin 947561

THE OILGEAR COMPANY

905 South Downing Street
 Fremont, NE 68025 USA
 www.oilgear.com

Table of Contents

Safety First	3 - 5
Preparation and Installation.....	6 - 7
Principle of Operation	8 - 9
Specifications	10
Troubleshooting.....	11
Testing and Adjusting / Disassembly	12 - 13
Rotating Group / Inspection.....	14 - 16
Assembly.....	16 - 17
PVG Pump Torques.....	18
Parts List.....	19 - 20
Service Kits.....	21 - 24
Cross Section and Exploded Views.....	24 - 28
Spare Parts Availability.....	29

Read and understand this entire instruction sheet before repairing, or adjusting your Oilgear product.

Those who use and maintain this equipment must be thoroughly trained and familiar with the product. If incorrectly used or maintained, this product and its equipment can cause severe injury.

SAFETY SYMBOLS

The following signal words are used in this instruction sheet to identify areas of concern where your safety may be involved. Carefully read the text and observe any instructions provided to ensure your safety.

DANGER

THIS SIGNAL WORD INDICATES AN IMMINENTLY HAZARDOUS SITUATION WHICH, IF NOT AVOIDED, WILL RESULT IN DEATH OR SERIOUS INJURY.

WARNING

This signal word indicates a potentially hazardous situation which, if not avoided, could result in death or serious injury.

CAUTION

This signal word indicates that a potentially hazardous situation exists which, if not avoided, may result in damage to equipment or minor personal injury.

NOTE

While not directly relevant to the topic being discussed, the NOTE is used to emphasize information provided, or provide additional information which may be of benefit.

WARNING

This service information is designed for the maintenance of your Oilgear product. It contains the information on the correct procedures determined by Oilgear for the safe manner of servicing. Always keep this instruction sheet in a location where it is readily available for the persons who use and maintain the product. Additional copies of this instruction sheet are available through the Oilgear Company. Or visit our website: www.oilgear.com. Please contact us if you have any questions regarding the information in this instruction bulletin.

NOTE

The cleanliness of working on this pump or the hydraulic system is extremely important to the safety and reliability of the pump and the system. Always make sure the fittings are clean on the outside before removing them from their connections, are capped and plugged when removed and placed in a clean rag or container until they are reinstalled.

WARNING

Some service operations may require special tools or equipment. If you require information on these items, please contact Oilgear before attempting these repairs and service operations.

WARNING

Read, understand, and follow the safety guidelines, dangers, and warnings contained in this instruction sheet to promote reliable operation and prevent serious personal injury.

WARNING

DO NOT attempt to service this machinery in an environment where safety regulations are not established and in place.

WARNING

DO NOT operate the hydraulic system if a leak is present. Serious injury may result.

WARNING

Hydraulic systems operate under very high pressure. Hydraulic fluid escaping from a pressurized system can penetrate unprotected body tissue. DO NOT inspect for hydraulic leaks with bare hands or other exposed body parts. As a minimum, wear leather gloves prior to inspecting for leaks and use cardboard or wood. If leaks are present, relieve pressure and allow system to cool prior to servicing. If injured by escaping hydraulic oil, contact a physician immediately. Serious complications may arise if not treated immediately. If you have questions regarding inspecting for hydraulic leaks, please contact Oilgear prior to servicing.

⚠ WARNING

Hydraulic hoses and tubing must be inspected on a daily basis for leaks, cuts, abrasions, damage and improper clearance along any mounting frame for hidden damage before the unit is put into service. Replace damaged hoses or hoses you suspect are damaged before the system is returned to service! Hoses must be replaced every two years. Failure to properly inspect and maintain the system may result in serious injury.

⚠ WARNING

Hydraulic systems are hot. **DO NOT TOUCH!** Serious personal injury may result from hot oil. When you have completed working on the hydraulic system, thoroughly clean any spilled oil from the equipment. Do not spill any hydraulic fluids on the ground. Clean any hydraulic fluids from your skin as soon as you have completed maintenance and repairs. Dispose of used oil and system filters as required by law.

⚠ WARNING

Use correct hoses, fittings, and adapters with the correct SAE rating when replacing hoses to prevent possible serious injury. Always replace hoses, fittings, and adapters with replacements that have a proper, suitable, working pressure rating. Replacement hoses must be of the correct length and must comply with the hose manufacturer's and Oilgear's installation guidelines and recommendations.

⚠ WARNING

Hydraulic hoses have the SAE ratings marked on the hose to assist you in selecting the correct hose. The same manufacturer must supply any replacement hydraulic hoses and fitting assemblies. As an example: Brand "X" hose and brand "Y" fitting will not normally be compatible. No "Twist" is allowed in the hydraulic hoses. "Twist" may result in premature hose failure. This can cause serious injury. Please contact Oilgear for assistance when required.

⚠ WARNING

Hydraulic cylinders can be holding a function in a certain position when the pump is OFF. An example of this is a function being held in the lift or partial lift position by the cylinders. If a hydraulic line is removed or the hydraulic circuits or controls are being worked on, gravity may allow the function being held in position to drop. All workers and personnel must remain clear of these areas when working on or operating the hydraulic system. Block and secure all devices and functions which apply before beginning work or operation. Failure to comply with this can result in serious injury or death.

⚠ WARNING

Any hydraulic pipe which is replaced must conform to SAE J1065 specifications. If incorrect hydraulic pipe is installed, the hydraulic system may fail, causing serious injury. Damaged or leaking fittings, pipes or hoses must be replaced before the system is returned to service.

⚠ WARNING

DO NOT heat hydraulic pipe. The carbon content of this steel tube is such that if heated for bending, and either water or air quenched, the pipe may lose its ductility and thereby be subject to failure under high pressure conditions. Serious injury can result. Damaged or leaking pipes must be replaced before the system is returned to service. Please contact Oilgear if you require assistance or have questions.

⚠ WARNING

All hydraulic pressure must be relieved from the hydraulic system prior to removing any components from the system. To relieve the hydraulic pressure from the hydraulic system, turn off the motor and operate the control panel with the key in the ON position. Failure to comply can result in serious injury. If you have any questions concerning relieving the hydraulic pressure from the system, please contact Oilgear.

⚠ WARNING

Hydraulic components can be heavy. Use caution while lifting these components. Serious personal injury can be avoided with proper handling of the components.

⚠ WARNING

Please contact Oilgear if you require assistance, when performing hydraulic test procedures, use the proper hydraulic gauges. Installing an incorrect test gauge could result in serious injury if the gauge fails. Use properly rated hydraulic hoses to allow the test gauge to be read away from moving parts and functions.

⚠ WARNING

Increasing hydraulic pressure beyond the recommendations may result in serious damage to the pump and system or serious personal injury and may void the Oilgear Warranty. If you have questions concerning hydraulic pressures or testing procedures, please contact Oilgear before attempting the test procedures or making adjustments.

⚠ WARNING

An Oilgear pump must not be modified in any way without authorization from Oilgear. Modifications may not comply with safety standards, including ANSI safety standards, and may result in serious personal injury. Please contact Oilgear if you require assistance.

⚠ WARNING

DO NOT enter under hydraulic supported equipment unless they are fully supported or blocked. Failure to follow this procedure can result in serious injury or death.

⚠ WARNING

Any Oilgear pump safety decals must be replaced anytime they are damaged, missing, or cannot be read clearly. Failure to have proper decals in place can result in serious injury or death. (If you require safety decals, please contact Oilgear for replacement safety decals, at no charge.)

⚠ WARNING

Be sure everyone is clear of the area around the hydraulic system before operating after servicing. Remain attentive at all times when operating to check your work until you are completely sure it is safe to return to service. Failure to heed this warning may result in serious personal injury or death.

⚠ WARNING

Wear the proper protective clothing when operating, servicing or maintaining the hydraulic system or the Oilgear pump. Wear the correct protective gear, safety glasses, gloves, and safety shoes. Serious injury can result without proper protective gear.

⚠ WARNING

Make sure to keep hands and feet and other parts of your body clear of revolving or moving parts. Failure to comply can cause serious injury.

⚠ WARNING

DO NOT wear watches, rings, or jewelry while working with electrical and mechanical equipment. These items can be hazardous and can cause serious and painful injuries if they come into contact with electrical wires, moving parts, or hydraulic equipment.

PREPARATION AND INSTALLATION

MOUNTING

Pump Without Reservoir - The pump can be mounted in any position. But, the recommended mounting position is with the drive shaft on a horizontal plane and the case drain port 1 on the top side. Secure the pump to a rigid mounting surface. Refer to the referenced Oilgear Piping Information Bulletin 90011.

Pump With Reservoir - These pumps are usually fully piped and equipped. It may be necessary to connect to a super-charge circuit when used. Mount reservoir on level foundation with the reservoir bottom at least six inches above floor level to facilitate fluid changes.

PIPING AND FITTINGS

Refer to the referenced Oilgear Piping Information Bulletin 90011 and individual circuit diagram before connecting the pump to the system. Inlet velocity must not exceed 5 fps (1,5 mps). Inlet should be unrestricted and have a minimum of fittings.

NOTE *DO NOT use an inlet strainer.*

Arrange line from "case drain" so the case remains full of fluid (non-siphoning). Case pressure must be less than 25 psi (1,7 bar). For higher case pressures, special shaft seals are required; contact our Customer Service. Each drain line must be a separate line, unrestricted, full sized and connected directly to the reservoir below the lowest fluid level. Make provisions for opening this line without draining (siphoning) reservoir.

WARNING

Running the pump in NEUTRAL position (zero delivery) for extended periods without a supercharge circuit can damage the pump. The system and pump must be protected against overloads by separate high pressure relief valves. Install bleed valve(s) at the highest point(s) in system.

POWER

Power is required in proportion to volume and pressure used. Motor size recommendations for specific applications can be obtained from The Oilgear Company. Standard low starting torque motors are suitable for most applications.

CAUTION

DO NOT start or stop unit under load unless system is approved by Oilgear. It may be necessary to provide delivery bypass in some circuits.

DRIVE

Verify rotation direction plate on the pump's housing. Clockwise pumps must be driven clockwise and counterclockwise pumps must be driven counterclockwise. Use direct drive coupling. Size and install coupling per manufacturer's instructions.

CAUTION

DO NOT drive the coupling onto the pump drive shaft. If it is too tight, it may be necessary to heat coupling for installation. Refer to manufacturer's instructions.

Misalignment of pump shaft to driver's shaft should not exceed 0.005 inches (0,13 mm) Total Indicator Readout (TIR) in any plane.

FILTRATION

Keep the fluid clean at all times to ensure long life from your hydraulic system. Refer to the referenced Oilgear Filtration Recommendations bulletin 90007 and Oilgear Contamination Evaluation Guide Bulletin 90004. Oilgear recommends use of a filter in the pressure or return line. Replace filter element(s) when the filter condition indicator reaches change area at normal fluid temperature. Drain and thoroughly clean filter case. Use replacement element(s) of same beta 10 ratio (normally a ratio of 4 with hydraulic oils).

FLUID COOLING

When the pump is operated continuously at the rated pressure or frequently at peak load, auxiliary cooling of the fluid may be necessary. Fluid temperature should not exceed limits specified in the referenced Oilgear Fluid Recommendations Bulletin 90000.

AIR BREATHER

On most installations, an air breather is mounted on top of fluid reservoir. It is important for the breather to be the adequate size to allow air flow in and out of reservoir as fluid level changes. Keep the breather case filled to the "fluid level" mark. About once every six months, remove cover, wash screen in solvent and allow screen to dry, clean and refill case to level mark and install screen. Refer to the manufacturer's recommendations.

FLUID, FILLING AND STARTING RECOMMENDATIONS

Refer to instruction plate on the unit, reservoir, machine and/or reference, Fluid Recommendations bulletin. Fire resistant fluids and phosphate ester fluids can be used in accordance with fluid manufacturer's recommendations.

1. Pump all fluid into reservoir through a clean (beta 10 ratio of 4 or more) filter. Fill reservoir to, but not above, "high level" mark on the sight gauge.
2. **Remove case drain line and fill pump case with hydraulic fluid.**
3. Turn drive shaft a few times by hand with a spanner wrench to make sure parts rotate. Torque to turn drive shaft should be 9 to 24 ft•lb (12 to 32 N•m).

With pump under "no load" or with pump control at NEUTRAL:

4. Turn drive unit ON and OFF several times before allowing pump to reach full speed. The system can usually be filled by running the pump and operating the control.
5. The fluid level in the reservoir should decrease. Stop the pump. **DO NOT** allow the fluid level to go beyond the "low level." If the level reaches "low level" mark, add fluid and repeat step.

NOTE

With differential (cylinder) systems, the fluid must not be above "high level" when the ram is retracted or below "low level" when extended. Bleed air from the system by loosening connections or opening petcocks at the highest point in the system. Close connections or petcocks tightly when solid stream of fluid appears.

CONSTRUCTION

See **Figure 3**.

1. A drive shaft (**301**) runs through the center line of pump housing (**001**) and valve plate (**401**) with the pump cylinder barrel (**101**) splined to it.
2. A bearing (**306**) supports the outboard end of the drive shaft.
3. The pump cylinder barrel is carried in a polymerous (journal type) cylinder bearing (**202**).
4. The valve plate (**401**) has two crescent shaped ports.
5. The pumping piston/shoe assemblies (**102**) in the cylinder barrel are held against a swashblock (**201**) by a shoe retainer (**104**).
6. The shoe retainer is held in position by the fulcrum ball (**103**) which is forced outward by the shoe retainer spring (**105**).
7. The spring acts against the pump cylinder barrel, forcing it against the valve plate while also forcing the piston shoes against the swashblock.
8. The semi-cylindrical shaped swashblock limits the piston stroke and can be swiveled in arc shaped saddle bearings (**204**).
9. The swashblock is swiveled by a control (included in referenced material). Refer to **PRINCIPLE OF OPERATION**.

PRINCIPLE OF OPERATION

The illustrations show the pump driven clockwise (right hand) from the top (plan) view.

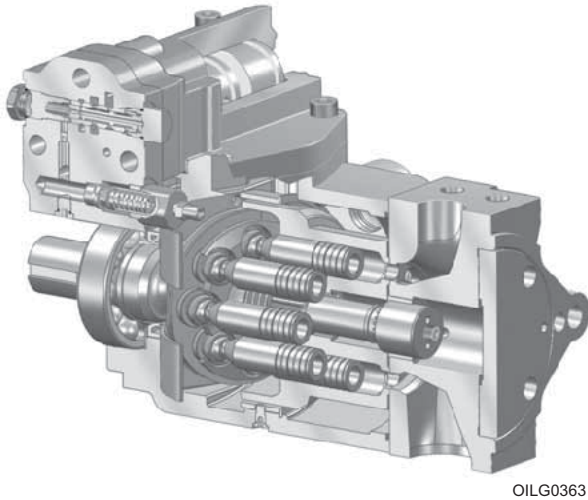

Figure 2. Cut-a-way of a Typical "PVG" Pump

Position B, Pump During Full Delivery From PORT B - Figure 3

Rotating the drive shaft (301) clockwise turns the splined cylinder, which contains the pumping pistons (102). When the cylinder rotates, the pistons move in and out within their bores as the shoes ride against the angled (C) swashblock (201).

As the cylinder rotates, the individual piston bores are connected, alternately, to the crescent shaped upper (port A) and lower (port B) in the valve plate. While connected to the upper side (suction) port A, each piston moves outward **OUT**, drawing fluid from port A into the piston bore until its outermost stroke (D) is reached. At this point, the piston bore passes from the upper crescent port A to the lower crescent port B.

While rotating across the lower crescent, each piston moves across the angled swashblock face and then each piston is forced inward **IN**. Each piston then displaces fluid through the lower crescent to port B until its innermost stroke (D) is reached. At this point, the piston bore passes from the lower to the upper crescent again and the cycle is repeated.

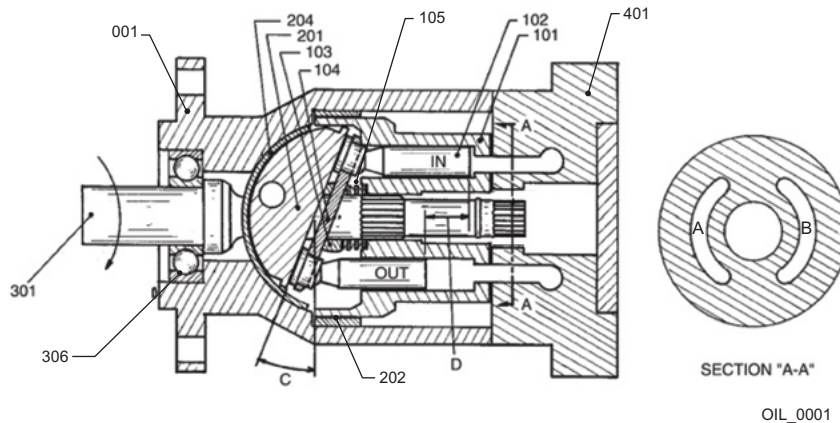

Figure 3. Position B, Pump During Full Delivery From Port B

Position B/2, Pump During One Half Delivery From PORT B - Figure 4

This illustration shows that the angle (E) of the swashblock determines the length of the piston stroke (F), (the difference between outermost and innermost position) which determines the amount of delivery from the pump. In this case, the stroke angle (E) is one-half of the stroke, which means the piston stroke is one-half and the pump delivery is one-half.

Position N, Pump In Neutral, No Stroke, No Delivery - Figure 5

Neutral position results when the control centers the swashblock. The swashblock angle (G) is now zero and swashblock face is parallel to the cylinder face. There is no inward or outward motion of the pump pistons as piston shoes rotate around the swashblock face. With no inward and outward motion or no stroke (H), **NEUTRAL** no fluid is being displaced from the piston bores to the crescents in the valve plate and there is no delivery from pump ports.

NOTE Illustration reference numbers match the part item number in the parts list.

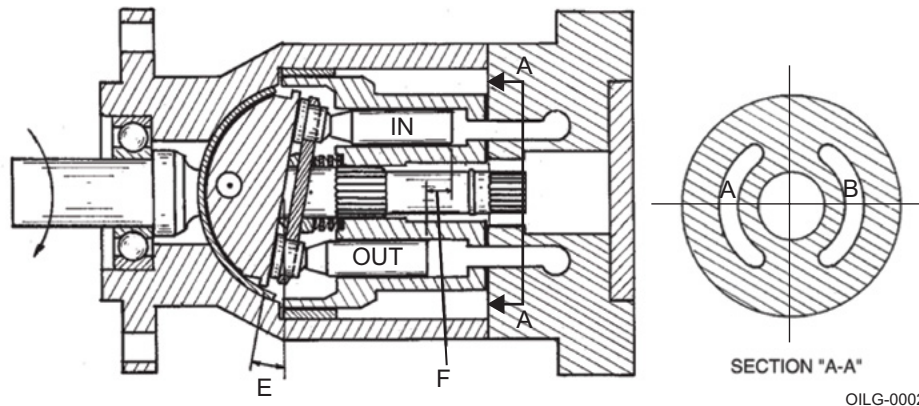

Figure 4. Position B/2, Pump During One Half Delivery From Port B

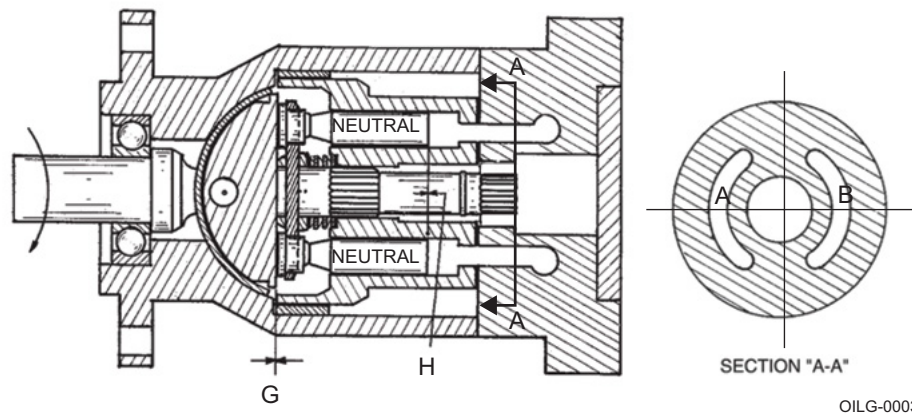

Figure 5. Position N, Pump In Neutral, No Stroke, No Delivery

Refer to **SPECIFICATIONS**

SPECIFICATIONS

NOTE Refer to reference material, pump control material and individual application circuit for exceptions.

Unit	THEORETICAL MAXIMUM DISPLACEMENT		RATED CONTINUOUS PRESSURE		PEAK PRESSURE		FLOW RATE at 1800 rpm rated continuous pressure and 14,7 psia (bar abs) inlet condition		MAXIMUM SPEED	POWER INPUT at rated continuous pressure & 1800 rpm	
	in 3/rev	ml/rev	psi	bar	psi	bar	gpm	l/mi	rpm	hp	kw
PVG 100	6.00	98,3	5000	344,8	5800	400,0	42.4	160,5	2400	150	111,9
PVG 130	7.94	130,2	3750	258,6	4250	293,1	57.6	218,0	2400	150	111,9

Case pressure should be less than 25 psi (1,7 bar). For higher pressure, consult factory.
 Higher speeds available - consult factory.

Table 1. Nominal Performance Data with 150-300 SSU viscosity fluids.

Unit	Length		Width		Height		Weight		Face Mounting
	inches	mm	inches	mm	inches	mm	lbs.	kg	
PVG 100, 130	13.0	330,5	8.4	213	7.3	185,7	115*	52	SAE "C" 2 bolt

All dimensions (without controls) are approximate. For detailed dimensions, contact your Oilgear Representative.
 * Weight with P Control and rear port valve plate

Table 2. Nominal Dimensions without controls.

Refer to installation drawings for more detailed dimensions and port configurations.

TROUBLESHOOTING		
PROBLEM	CAUSES	REMEDY
Unresponsive or Sluggish Control	Low control input (pilot) pressure for "R" and "V" volume type controls only.	Refer to referenced control instruction material.
	Swashblock saddle bearings (204) worn or damaged.	Inspect bearings. Replace.
Insufficient Pump Volume	Delivery limited by faulty control	Refer to appropriate control instruction material.
	Obstructed suction circuit or insufficient supercharge volume.	Inspect for obstruction and verify supercharge.
	Insufficient drive motor speed.	Refer to appropriate power material.
	Worn or grooved cylinder barrel (101) and/or valve plate (401) mating surfaces.	Inspect components. Replace.
	Worn piston/shoe assemblies (102) or piston bores in cylinder (101).	
Worn or damaged piston shoe or swashblock (201).		
Irregular or Unsteady Operation	Faulty control.	Inspect components. Replace. Refer to referenced pump control instruction materials.
	Fluid level in reservoir is low or supercharge is insufficient.	Verify fluid level and/or supercharge.
	Air entering hydraulic system.	Inspect system for leak.
	Worn axial piston pump.	Inspect components. Replace.
	Faulty output circuit components (cylinder, motors, valves or other related components).	Inspect components. Replace.
Loss of Pressure	Worn piston pump.	Inspect components. Replace.
	Worn or grooved cylinder barrel (101) and/or valve plate (401) mating surfaces.	
	Worn piston/shoe assemblies (102) or piston bores in cylinder.	
	Faulty output circuit components.	
Excessive or High Peak Pressure	Faulty output circuit components.	Check the relief valves.
Excessive Noise	Pump stopped or started incorrectly under load.	Verify operation procedure of pump.
	Low fluid level in reservoir or insufficient supercharge causing cavitation.	Verify fluid level and/or supercharge.
	Air entering hydraulic system.	Inspect system for leak.
	Fluid too cold or viscosity too high.	Verify fluid temperature and/or type.
	Suction line problem i.e.; obstructions in line, line too long, line diameter too small or too many bends and/or loops in line.	Inspect line for obstruction.
	Broken or worn piston/shoe assembly (102).	Inspect components. Replace.
	Pump rotating in wrong direction.	Inspect operation direction of pump.
Excessive Heating	Operating pump above rated or peak pressure.	Verify pump limitations.
	Low fluid level in reservoir or insufficient supercharge.	Verify fluid level and/or supercharge.
	Air entering hydraulic system.	Inspect system for leak.
	Worn piston pump.	Inspect components. Replace.
	Worn or grooved cylinder barrel (101) and/or valve plate (401) mating surfaces.	
	Faulty output circuit components (continuous blowing relief valves or "slip" through valves, cylinder or other components).	
	Insufficient cooling provision or clogged coolers.	Inspect for obstruction.

TESTING AND ADJUSTING

WARNING

Shut the pump OFF and release pressure from the system before disassembling components. Failure to comply with these instructions could result in personal injury or death. Blocking the pressure line between the pump and the system (or pump) high pressure relief valve will result in damage and could result in serious personal injury.

PISTON PUMP

To check for a worn piston pump, make a leak measurement test from the case drain while the pump is under pressure. After the unit is warm, either install a flow meter in the drain line or have the flow from the drain line directed into a large container or reservoir. The pump case must remain full of fluid during this test.

CAUTION

DO NOT run a pump on stroke against a blocked output unless it is protected by a high pressure relief valve and then run no longer than necessary to check slip. Limit discharge to prevent dropping reservoir fluid below low level.

With an accurate high pressure gauge in the pressure line, start the pump and stall (or block) output device to raise system pressure to maximum (as set by system relief valve). Read the measurement on the flow meter or time and measure the case drain flow to fill a known size container and calculate the flow rate.

NOTE *Additional leakage indicates wear, but does not become critical until it impairs performance.*

DISASSEMBLY

NOTE

The cleanliness of working on this pump or the hydraulic system is extremely important to the safety and reliability of the pump and the system.

When disassembling or assembling the pump, choose a clean, dry, dust and sand free area where no traces of abrasive particles are in the air which can damage the pump and system. DO NOT work near welding, sandblasting, grinding benches or similar conditions.

Always make sure the fittings are clean on the outside before removing them from their connections. Make sure they are capped and plugged when removed. Place them on a clean surface and in a clean rag or container until they are reinstalled. When cleaning parts which have been disassembled, it is important to use CLEAN cleaning solvents and parts are allowed to dry. All tools and gauges should be clean prior to working with the system and use new, CLEAN lint free rags to handle and dry parts.

WARNING

DO NOT attempt to remove or install any components or assembly while the pump and system is running. Always stop the pump, shut OFF the power and release pressure from the system before servicing or testing. Be sure provisions have been made so the case drain line can be disconnected from the unit without causing the line to drain (siphon) the reservoir.

(continued)

DISASSEMBLY (Continued)

1. Disconnect case drain line from port **1** or **1A**.
2. Drain pump case through the remaining (port **1** or **1A**) on the bottom of case. If plugs are inaccessible, it may be necessary to remove the pump from the mounting and drive motor before draining it.
3. After removing the pump from the mounting and before disassembly, cap or plug all ports and clean the outside of unit thoroughly to prevent dust from entering the system. See **Figures 8** and **9**.

NOTE

Depending on what part or parts are to be inspected, it may not be necessary to completely take apart all assemblies.

CONTROL GROUP

Refer to the reference material for the information which applies to the control your pump is equipped with. Some force is required to remove the control housing.

1. Remove socket head cap screws.
2. Lift the control group assembly, with control pin, straight up from the top of the pump assembly. The control pin may or may not remain in the swashblock (**201**).
3. Remove control O-rings from the pump housing.

VALVE PLATE GROUP

If another pump is coupled to thru-shaft pumps, it will be necessary to remove coupling half before removing valve plate.

1. Block the pump on a bench with the drive shaft facing down.
2. Remove the valve plate (**401**) by removing four hex head cap screws (**403**) and lifting it straight up.
3. Remove valve plate O-ring (**404**) and (**411**).

ROTATING GROUP

⚠ WARNING

The rotating group is heavy. Be careful not to damage cylinder wear surface which mates against the valve plate, bearing diameters or piston shoes. Use proper lifting techniques and assistance from others to prevent personal injury.

1. Place the pump in a horizontal position.
2. Remove the rotating group by turning shaft (301) slowly, while pulling the cylinder barrel (101) from the housing.
3. Identify (number) each pump piston shoe assembly (102) and its respective bore in the cylinder barrel (101) and shoe retainer (104) for easy reassembly.
4. See Figure 6. Lift out shoe retainer (104) with pistons (102) and remove the fulcrum ball (103) and shoe retainer spring (105).

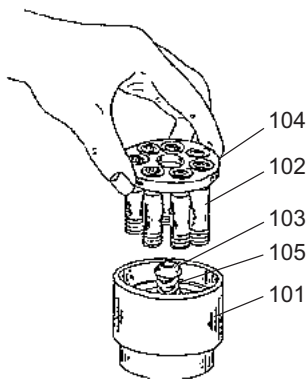

OILG-0004

Figure 6. Rotating Group Disassembly (5V-12015-L).

5. Remove retaining ring (208) and plug (205) and pull the hydrodynamic bearing (202) from the housing.

DRIVE SHAFT GROUP

1. Remove the drive key (303), if used and the drive shaft bearing retainer ring (305).
2. Grasp outboard end of drive shaft (301) and pull it out of the pump housing.
3. Remove the shaft seal retainer (302) and shaft seal (007) from the housing only if necessary.

SWASHBLOCK GROUP

Remove screws (206) and guide plate (203) first. Reach inside the case and remove the swashblock (201) and saddle bearings (204).

INSPECTION

Clean all parts thoroughly and allow them to dry. Inspect all seals and O-rings for hardening, cracking or deterioration. Replace if necessary or if you suspect damage. Check all locating pins for damage and springs for cracking or signs of wear.

⚠ WARNING

Wear proper protective gear when using solvents or compressed air, servicing or maintaining the hydraulic system or the Oilgear pump. Wear correct protective gear, safety glasses, gloves, and safety shoes. Serious injury can result without proper protective gear.

CONTROL GROUP

Refer to the reference material on pump controls. Be sure to carefully check the control pin for cracks and/or signs of fatigue. Check fit of the pin in the swashblock. It should be a slip-fit without side-play. Replace if necessary or if you suspect damage.

VALVE PLATE GROUP

Inspect the valveplate (401) surface which mates with the cylinder barrel (101) for excessive wear. Remove minor defects by lightly stoning the surface with a hard stone which is flat to within 0.001 inches (0,03 mm).

NOTE *Be sure to stone lightly. Any excessive stoning will remove the hardened surface. If wear or damage is extensive, replace the valve plate.*

ROTATING GROUP

Inspect cylinder barrel (101) piston bores and the face which mate with the valve plate for wear. Remove minor defects on the face by lightly stoning or lapping the surface.

Inspect the cylinder bearing (202) for damage and replace if necessary. Check all piston and shoe assemblies (102) to be sure they ride properly on the swashblock.

NOTE *Be sure to stone lightly. Any excessive stoning will remove the hardened surface. If wear or damage is extensive and defects cannot be removed, replace the cylinder barrel.*

See **Figure 7**. Check each shoe face for nicks and scratches, and the shoe for smooth pivot action on the piston.

NOTE *If one or more piston/shoe assembly needs to be replaced, replace all the piston/shoe assemblies. When installing new piston/shoe assemblies or the rotating group, make sure the pistons move freely in their respective bores.*

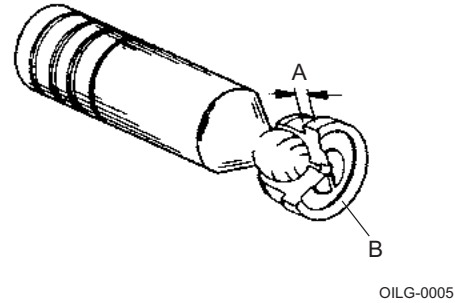

Figure 7. Piston and Shoe Inspection (5V-12015-L)

- (A) All shoes must be equal within 0.001 inches (0,025 mm) at this dimension.
- (B) All shoe faces must be free of nicks.

NOTE *End play should not exceed 0.003 inches (0,076 mm) when new or 0.006 inches (0,152 mm) when worn.*

SWASHBLOCK GROUP

Inspect the swashblock (201) for wear. If defects are minor, stone the swashblock lightly. If damage is extensive, replace the swashblock.

Check the small hole in the face of the swashblock. The hole provides “porting” for the hydrostatic balance fluid of the piston/shoe assembly to be channeled through the swashblock to the face of the saddle bearing, providing pressure lubrication.

Compare the saddle bearing (204) thickness in a worn area to thickness in an unworn area. Replace saddle bearings if the difference is greater than 0.015 inches (0,4 mm).

Check the mating surface of swashblock for cracks or excessive wear. The swashblock movement in the saddle bearings must be smooth. Replace if necessary.

NOTE *Be sure to stone lightly. Any excessive stoning will remove the hardened surface. If wear or damage is extensive and defects cannot be removed, replace if necessary or if you suspect them of being bad.*

DRIVE SHAFT GROUP

Check:

- the shaft seal **(007)** for deterioration or cracks. Replace if necessary (press-out).
- the shaft bearing **(306)** for galling, pitting, binding or roughness.
- the rear shaft bushing in valve plate.
- the shaft and its splines for wear. Replace any parts necessary.

ASSEMBLY

See **Figures 8** and **9**. Follow the disassembly procedures in reverse for re-assembling the pump.

During assembly, install new seals and O-rings. Apply a thin film of CLEAN grease or hydraulic fluid to sealing components to ease assembly. If a new rotating group is used, lubricate thoroughly with CLEAN hydraulic fluid. Apply fluid generously to all wear surfaces.

SWASHBLOCK GROUP

If removed,

1. Press shaft seal **(007)** into front of pump housing.
2. Place housing on a bench with the mounting flange side down.
3. Grease the back side of each saddle bearing **(204)** and place on the pin to locate the bearings in the pump case. Make sure the pins do not protrude.
4. The swashblock is inserted from the valve plate end. Insert swashblock **(201)** into the pump housing. Once in place, be sure the swashblock swivels in the saddle bearings. With new bearings, swiveling may be stiff and not always smooth. Assemble **(203)** and **(206)**.

5. The bearing **(202)** should be positioned with “scarf” cuts (PVG 130 only) positioned top and bottom. The bearing should fit into place with a little difficulty and be square to the axis of the pump.
6. Tap bearing into place if necessary using extreme care not to damage the bearing.
7. Insert retaining ring **(208)** to hold bearing in place. Assemble plug **(205)** with O-ring **(209)** into case.

DRIVE SHAFT GROUP

1. Place the housing on its side with the axis horizontal.
2. Install the seal retainer **(302)**.
3. Lubricate the shaft seal **(007)** and shaft.
4. Insert the drive shaft **(301)** and bearing assembly into the housing.
5. Lock in place with the drive shaft bearing retainer ring **(305)**.

ROTATING GROUP

See **Figure 6**.

1. Place the cylinder barrel **(101)**, wear surface down, on a clean cloth.
2. Place the shoe retainer spring **(105)** in the center of the barrel with the fulcrum ball **(103)** on top of it.
3. Insert the identified pistons **(102)** into their corresponding identified holes of the shoe retainer **(104)**. As a unit, fit the pistons into their corresponding, identified bores in the cylinder barrel. **DO NOT FORCE**. When parts are aligned properly, the pistons will fit smoothly.

⚠ WARNING

The rotating group weight is heavy. Be careful not to damage cylinder wear surface which mates against the valve plate, bearing diameters or piston shoes. Use proper lifting techniques and assistance from others to prevent personal injury.

The rotating group can now be carefully installed over the end of the drive shaft (301) and into the pump housing (001).

NOTE *When installing the rotating group, support the weight of the cylinder barrel (101), as cylinder spline is passed over the tailshaft, to avoid scratching or damage.*

4. Push cylinder forward until the cylinder spline reaches the drive shaft spline and rotate slightly to engage shaft splines. Continue to slide cylinder forward until it encounters the cylinder bearing (202). Lifting the rear of the shaft slightly helps the cylinder (101) and the cylinder bearing (202) engagement. Continue pushing the cylinder forward until the piston shoes contact the swashblock, the back of the cylinder should be located approximately 0.4 inches (10,2 mm) outside the back of the pump housing.

VALVE PLATE GROUP

1. Place the pump housing on a bench with the open end facing up.
2. Install new O-rings (404) and (411) on the housing.
3. Position the valve plate (401) on pins (005) and housing.
4. Hand-tighten the hex head cap screw (403) closest to O-ring (404) first, then alternately tighten the other cap screws. On thru-shaft units connected to another pump or device, install coupling (501).

Refer to **PREPARATION** and **INSTALLATION** when pump is ready to be returned to service.

PVG Pump	Fastener or Plug	Head Type/Size	Tightening Torque
100/130	002	1/4 int.	200 in•lb (23 N•m)
	004	5/8 int.	135 ft•lb (183 N•m)
	205	1/8 int.	45 in•lb (5 N•m)
	206	5/32 int.	87 in•lb (10 N•m)
	308	5/32 int.	87 in•lb (10 N•m)
	403	13/16 ext.	100 ft•lb (136 N•m)
	408	1/8 int.	45 in•lb (5 N•m)
	409	1/8 int.	45 in•lb (5 N•m)
	410	3/16 int.	120 in•lb (14 N•m)
	503	Depends on adapter	
	3/8 SHC	5/16 int.	45 ft•lb (61 N•m)
	3/8 HHC	9/16 ext.	15 ft•lb (20 N•m)
	1/2 HHC	3/4 ext.	37 ft•lb (50 N•m)
	5/8 HHC	15/16 ext.	74 ft•lb (100 N•m)
	507	5/16 int.	45 ft•lb (61 N•m)

Table 3. PVG Pump Torques

PARTS LIST

Parts used in these assemblies are per Oilgear specifications. Use only Oilgear parts to ensure compatibility with assembly requirements. When ordering replacement parts, be sure to include pump type and serial number, bulletin number and item number. Specify type of hydraulic fluid to assure seal and packing compatibility.

NOTE

Parts drawings may not be identical to Oilgear drawings referenced.

Item	Qty.	Description
HOUSING ASSEMBLY GROUP		
001	1	Housing, Pump
002	1	Plug
003	1	Nameplate, Identification
004	1	Plug
005	2	Pin, Roll
006	2	Pin, Roll
007	1	Seal, Shaft
008	2	Screw
009	2	Pin, Swashblock Bearing
010	1	Seal, O-ring
011	1	Seal, O-ring
ROTARY ASSEMBLY GROUP		
101	1	Barrel, Cylinder
102	9	Assembly, Piston/Shoe
103	1	Ball, Fulcrum
104	1	Retainer, Shoe
105	1	Spring, Shoe Retainer
SWASHBLOCK ASSEMBLY GROUP		
201	1	Swashblock
202	1	Bearing, Cylinder
203	1	Guide Plate
204	2	Bearing, Swashblock
205	1	Plug, Bearing Retainer
206	2	Screw
208	1	Ring, Retainer
209	1	Seal, O-ring

PARTS LIST drawings on pages 25 through 28.

Parts are common between pumps. Only the differences are shown.

**O-ring Sizes
 ARP 568 Uniform Size Number with
 Durometer**

Item Number	PVG Pump 100/130
010	916 - 70
011	906 - 90
404	013 - 90
405	902 - 90
406	903 - 90
407	904 - 90
411	257 - 70

Item	Qty.	Description
DRIVE SHAFT ASSEMBLY GROUP		
301	1	Drive Shaft
302	1	Retainer, Seal Side
303	1	Key, Drive Shaft (keyed shafts only)
304	1	Ring, Retainer, External
305	1	Ring, Retainer, Internal
306	1	Bearing, Front
VALVE PLATE ASSEMBLY GROUP		
401	1	Valve Plate
403	4	Screw, Hex Head Cap
404	1	Seal, O-ring
405	1	Seal, O-ring
406	1	Seal, O-ring (not required for all versions)
407	1	Seal, O-ring
408	1	Plug, #2 HP
409	1	Plug, #3 HP (not required for all versions)
410	1	Plug, #4 HP
411	1	Seal, O-ring

PARTS LIST drawings on pages 25 through 28.

Parts are common between pumps. Only the differences are shown.

Parts used in this assembly are per Oilgear specifications. Use only Oilgear parts to ensure the compatibility with the assembly requirements. When ordering replacement parts, be sure to include pump type and serial number, bulletin number and item number. To assure seal and packing compatibility, specify type of hydraulic fluid.

SERVICE KITS

PVG C Pump Service Kits

SERVICE KIT Drawings on pages 25 through 28.

Description	Kit No.	Design Series	Items Included (quantity is 1 unless noted)
Shaft & Bearing Kits			
Viton or Nitrile seals			
1.50" Dia. Keyed (Code Z) Short	L516175-301	All(B)	301, 302, 303, 304, 305, 306
1.50" Dia. Keyed (Code Y) Std	L516175-307	All(B)	301, 302, 303, 304, 305, 306
14T, 12/24 Spline (Code K) Std	L516175-305	All	301, 302, 304, 305, 306
17T, 12/24 Spline (Code S) Std	L516175-302	All	301, 302, 304, 305, 306
1.50" Dia. Keyed (Code Z) T-S Short	L516175-303	All(B)	301, 302, 303, 304, 305, 306
1.50" Dia. Keyed (Code Y) T-S	L516175-308	All(B)	301, 302, 303, 304, 305, 306
14T, 12/24 Spline (Code K) T-S	L516175-306	All	301, 302, 304, 305, 306
17T, 12/24 Spline (Code S) T-S	L516175-304	All	301, 302, 304, 305, 306
EPR Seals			
1.50" Dia. Keyed (Code Z) Short	L516175-328	All(B)	301, 302, 303, 304, 305, 306
1.50" Dia. Keyed (Code Y) Std	L516175-322	All(B)	301, 302, 303, 304, 305, 306
14T, 12/24 Spline (Code K) Std	L516175-324	All	301, 302, 304, 305, 306
17T, 12/24 Spline (Code S) Std	L516175-326	All	301, 302, 304, 305, 306
1.50" Dia. Keyed (Code Z) T-S Short	L516175-327	All(B)	301, 302, 303, 304, 305, 306
1.50" Dia. Keyed (Code Y) T-S	L516175-321	All(B)	301, 302, 303, 304, 305, 306
14T, 12/24 Spline (Code K) T-S	L516175-323	All	301, 302, 304, 305, 306
17T, 12/24 Spline (Code S) T-S	L516175-325	All	301, 302, 304, 305, 306
Std = Rear ported or Side ported w/o thru-shaft, T-S = Side ported w/ thru-shaft			
Swashblock			
All	K515794-010	All	201, 203, 206(2)
Saddle Bearing			
Standard	L516175-220	All	204A, 204B
High Temp	L516175-221	All	
Hydrodynamic Bearing Kit			
PVG-100			
Viton Seals	L516175-230	F1(D)	202, 205, 208, 209
PVG-130			
Viton Seals	L516275-230	F1(D)	202, 205, 208, 209
Rotating Group			
PVG-100	L516175-101	All	101, 102(9), 103, 104, 105
PVG-130	L516275-102	C2(C)	

PVG C Pump Service Kits

Reference: 516246-200 Ass'y Drwg

Description	Kit No.	Design Series	Items Included (quantity is 1 unless noted)
Valve Plate Kits			
PVG-100 Rear Port LH			
Viton Seals	L516175-401	All	401, 403(4), 404, 405, 407, 408, 410, 411
PVG-100 Rear Port RH			
Viton Seals	L516175-402	All	401, 403(4), 404, 405, 406, 407, 408, 409, 410, 411
PVG-100 Side Port LH			
Viton Seals	L516175-405	All	401, 403(4), 404, 405, 406, 407, 408, 409, 410, 411
PVG-100 Side Port RH			
Viton Seals	L516175-406	All	401, 403(4), 404, 405, 406, 407, 408, 409, 410, 411
PVG-100 Side Port, Thru-Shaft LH			
Viton Seals	L516175-403	All	401, 403(4), 404, 405(2), 406, 407, 408(2), 409, 410, 411
PVG-100 Side Port, Thru-Shaft RH			
Viton Seals	L516175-404	All	401, 403(4), 404, 405(2), 406, 407, 408(2), 409, 410, 411
PVG-130 Rear Port LH			
Viton Seals	L516275-401	C2(C)	401, 403(4), 404, 405, 407, 408, 410, 411
PVG-130 Rear Port RH			
Viton Seals	L516275-402	C2(C)	401, 403(4), 404, 405, 406, 407, 408, 409, 410, 411
PVG-130 Side Port LH			
Viton Seals	L516275-405	C2(C)	401, 403(4), 404, 405, 406, 407, 408, 409, 410, 411
PVG-130 Side Port RH			
Viton Seals	L516275-424	C2(C)	401, 403(4), 404, 405, 406, 407, 408, 409, 410, 411
PVG-130 Side Port, Thru-Shaft LH			
Viton Seals	L516275-403	C2(C)	401, 403(4), 404, 405(2), 406, 407, 408(2), 409, 410, 411
PVG-130 Side Port, Thru-Shaft RH			
Viton Seals	L516275-404	C2(C)	401, 403(4), 404, 405(2), 406, 407, 408(2), 409, 410, 411

PVG C Pump Service Kits

Reference: 516246-200 Ass'y Drwg

Description	Kit No.	Design Series	Items Included (quantity is 1 unless noted)
Basic Seal Kit			
Viton Seals	K516175-C11	All	007, 010, 011, 209, 404, 405(2), 406, 407, 411 Control 330, 313
Nitrile Seals	K516175-C12	All	
EPR Seals	K516175-C13	All	
Seal Kits for Options			
Standard Cover Plate			
Viton Seals	238270-145	All	505
Nitrile Seals	233370-145	All	
EPR Seals	242080-145	All	
SAE C Adapter			
Viton Seals	238270-049	All	505
Nitrile Seals	233370-049	All	
EPR Seals	242080-049	All	
SAE B Adapter			
Viton Seals	L250667-017	All	505, 506
Nitrile Seals	L250667-016	All	
EPR Seals	L250667-018	All	
SAE A Adapter			
Viton Seals	L250667-014	All	505, 506
Nitrile Seals	L250667-013	All	
EPR Seals	L250667-015	All	
Shaft Seal			
Viton Seals	51156-5	All	007
Nitrile Seals	51156-7	All	
EPR Seals	L51156-3RP	All	

PVG C Pump Service Kits

Reference: 516246-200 Ass'y Drwg

Description	Kit No.	Design Series	Items Included (quantity is 1 unless noted)
Cover Plate Kit			
Viton Seals	L319076-001	All	502, 503(4), 505
Nitrile Seals	L319076-013	All	
EPR Seals	L319076-301	All	
SAE C Adapter/Coupling Kit 14 Tooth			
Viton Seals	L319076	All	501, 503(2), 504(2), 505
Nitrile Seals	L319076-008	All	
EPR Seals	L319076-300	All	
SAE B-B Adapter/Coupling Kit 15 tooth			
Viton Seals	L319076-005	All	501, 502, 503(2), 504(2), 505, 506
Nitrile Seals	L319076-012	All	
EPR Seals	L319076-014	All	
SAE B Adapter/Coupling Kit 13 tooth			
Viton Seals	L319076-002	All	501, 502, 503(2), 504(2), 505, 506
Nitrile Seals	L319076-007	All	
EPR Seals	L319076-302	All	
SAE A Adapter/Coupling Kit 9 Tooth			
Viton Seals	L319076-003	All	501, 502, 503(2), 504(2), 505, 506, 507(4)
Nitrile Seals	L319076-011	All	
EPR Seals	L319076-303	All	
Name Tag & Screws			
All	L50921	All	003, 008(2)

Footnotes for Design Series

- (A) Not used
- (B) Code "Y" shaft is length of Code "Z" shaft for Design Series "A1"
 Parts are interchangeable between Design Series
- (C) PVG130 Valve plate and Rotating group must be matched
 A1, B1, C1 parts can be intermixed between series
 C2, D3, D4, E1, F1 parts can be intermixed between series
- (D) F1 pump case and hydrobearing are not interchangeable with previous design series
 F1 pump requires F1 control
 Pump cases are interchangeable prior to F1
 A1 series has #12 SAE threaded case drain connection
 B1, C1, C2, D3, D4, E1 have #16 SAE threaded case drain connection

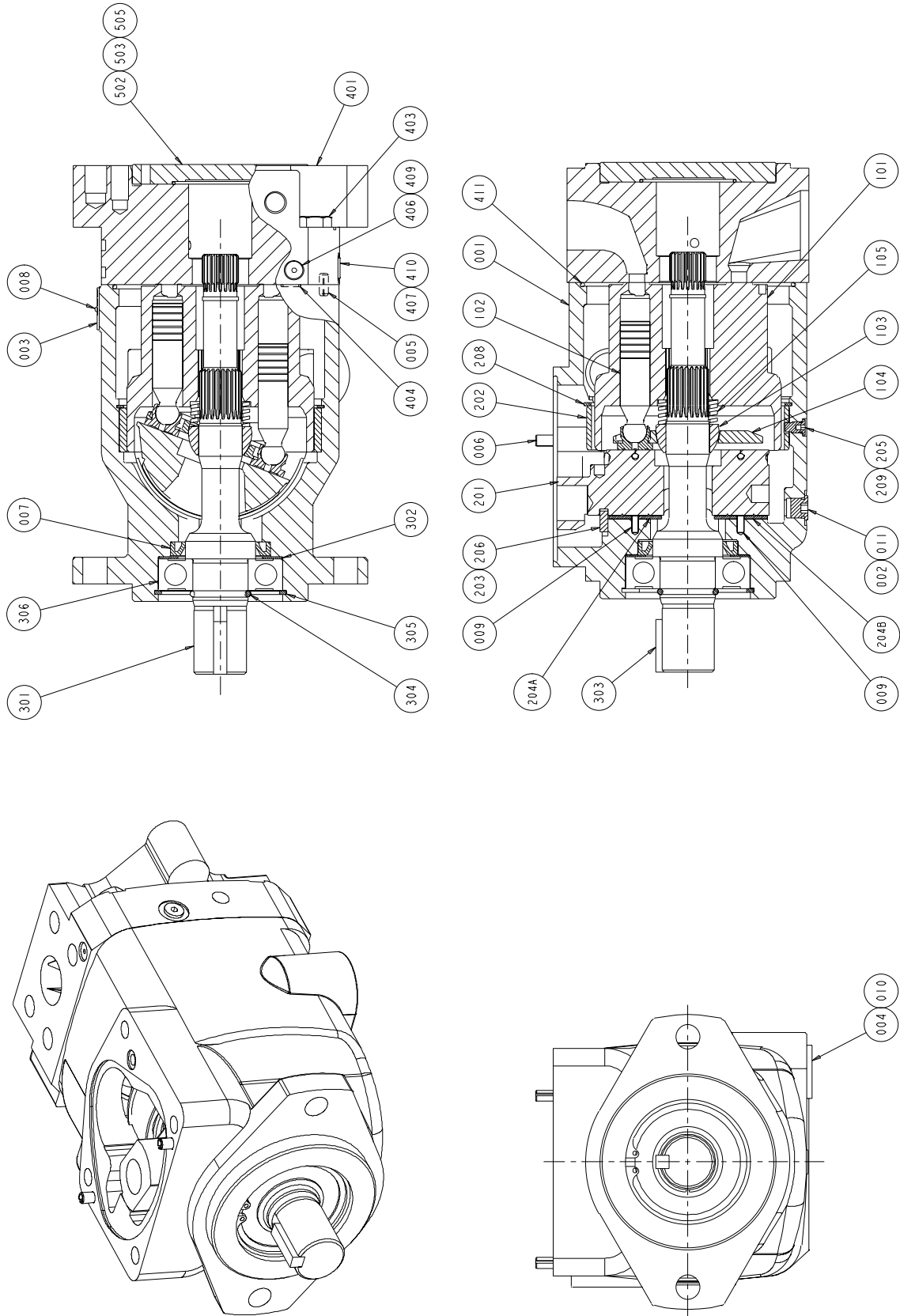

Figure 8. Cross Section and Exploded Parts Drawing for PVG 100 and 130 (516246-200 sheet 1 of 8)

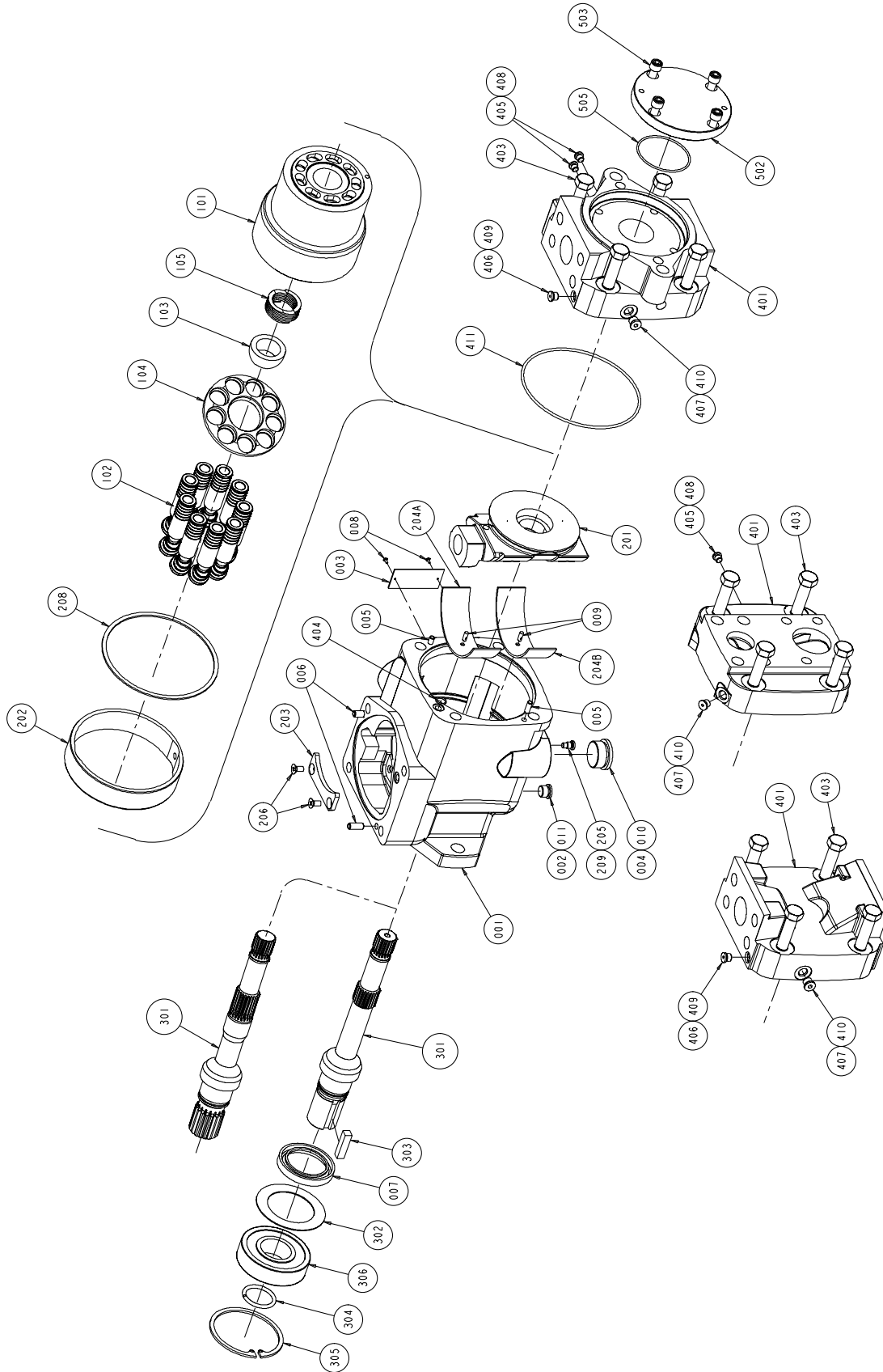
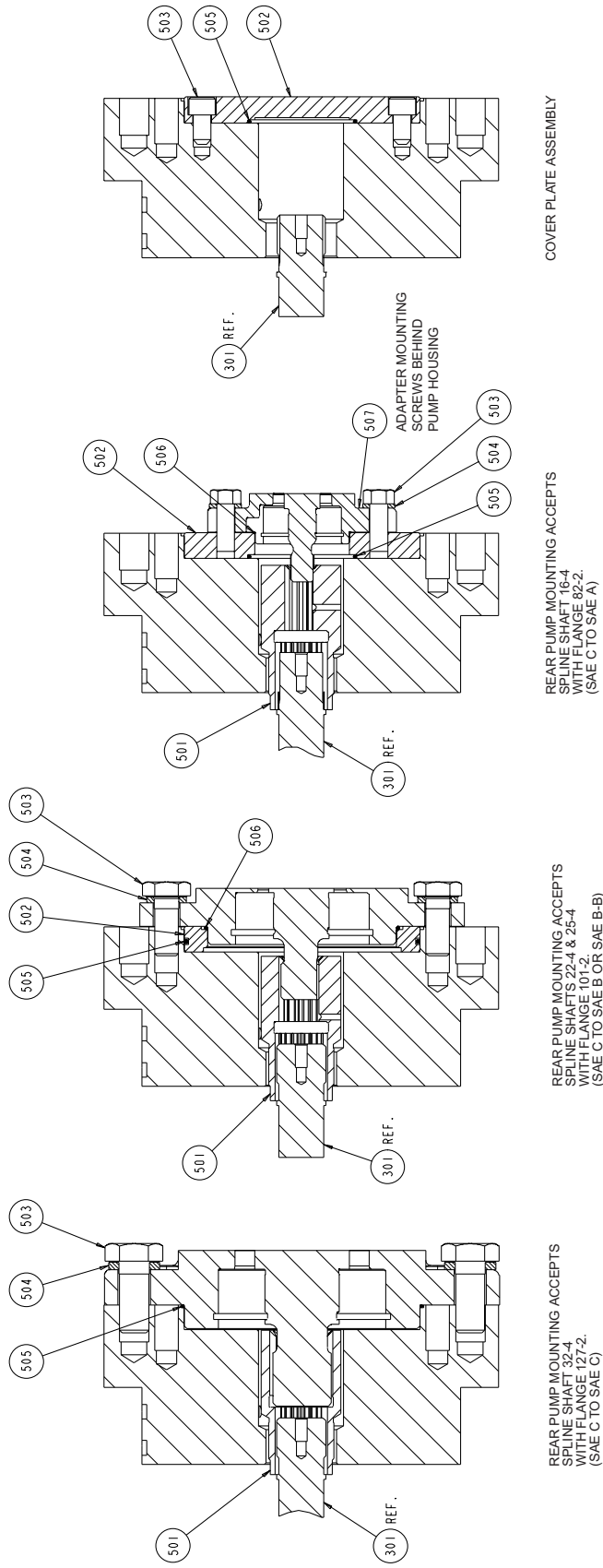

Figure 9. Exploded Parts Drawing for PVG 100 and 130 (516246-200 sheet 2 of 8)



COVER PLATE ASSEMBLY

REAR PUMP MOUNTING ACCEPTS
 SPLINE SHAFT 76-4
 WITH FLANGE 82-2.
 (SAE C TO SAE A)

REAR PUMP MOUNTING ACCEPTS
 SPLINE SHAFTS 22-4 & 25-4
 WITH FLANGE 101-2.
 (SAE C TO SAE B OR SAE B-B)

REAR PUMP MOUNTING ACCEPTS
 SPLINE SHAFT 32-4
 WITH FLANGE 127-2.
 (SAE C TO SAE C)

THRU-SHAFT OPTIONS

Figure 10. Cross Section Drawing for PVG 100 and 130 (516246-200 sheet 6 of 8)

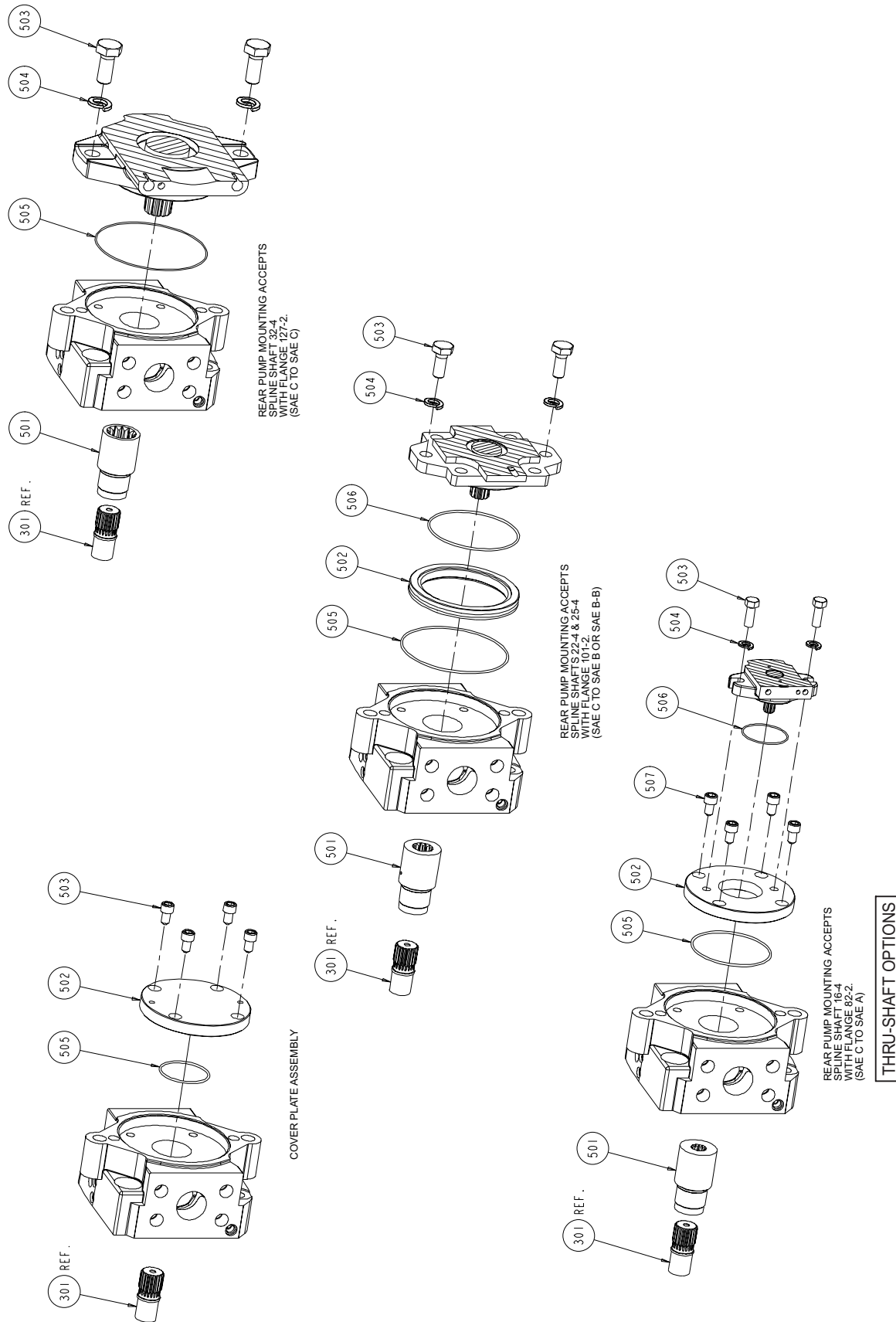

Figure 11. Cross Section and Exploded Parts Drawing for PVG 100 and 130 (516246-200 sheet 7 of 8)



SPARE PARTS AVAILABILITY

Prepare for your future needs by stocking Oilgear original factory parts. Having the correct parts and necessary skills “in-plant” enables you to minimize “down-time.” Oilgear has developed parts kits to cover likely future needs. Oilgear Field Service Technicians are also ready to assist you and your maintenance people in troubleshooting and repairing equipment.

THE OILGEAR COMPANY

905 South Downing Street
Fremont, NE 68025 USA
www.oilgear.com