

OILGEAR TYPE “PVV” PUMPS - 200/250/540 - B1 AND B2 SERIES SERVICE INSTRUCTIONS

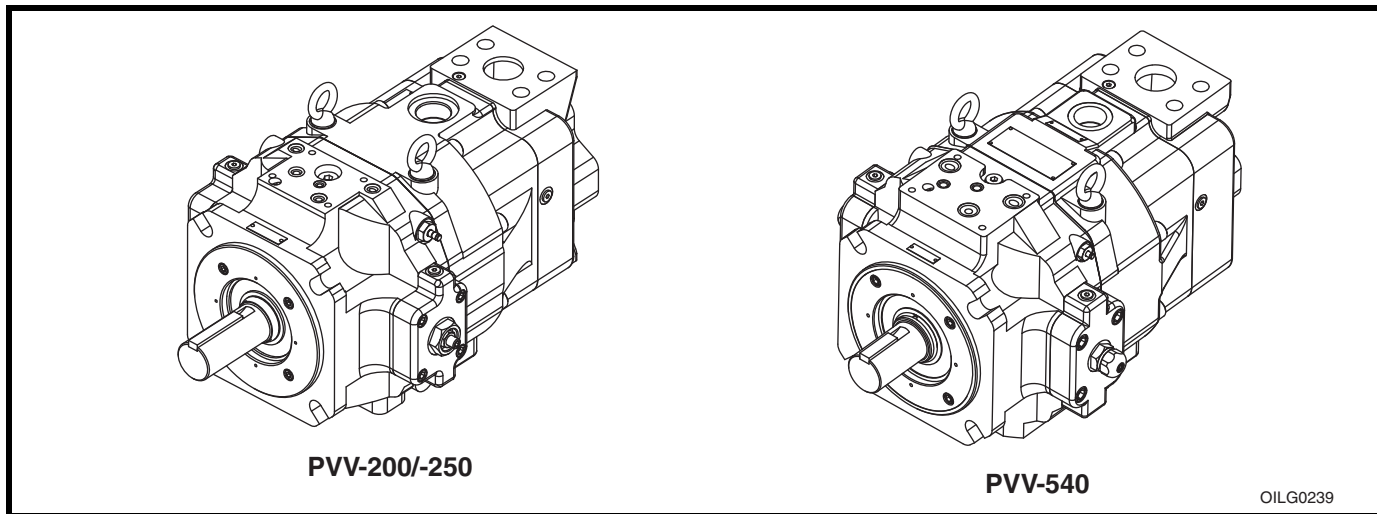

Figure 1. Oilgear “PVV-200/-250 and -540 B1 and B2 Series” Open Loop Pump

PURPOSE OF INSTRUCTIONS

These instructions will simplify the installation, operation, maintenance and troubleshooting of Oilgear type “PVV” pumps.

Become familiar with the construction, principle of operation and characteristics of your pump to help you attain satisfactory performance, reduce shut-down and increase the pump’s service life. Some pumps have been modified from those described in this bulletin and other changes may be made without notice.

REFERENCE MATERIAL

Fluid Recommendations	Bulletin 90000
Contamination Evaluation Guide	Bulletin 90004
Filtration Recommendations	Bulletin 90007
Piping Information	Bulletin 90011
Installation of Vertically Mounted Axial Piston Units	Bulletin 90014
PVV Open Loop Pumps Sales Brochure	Bulletin 47028-C

Pump Control Instructions

V-M Control, PVV-200/-250 ..Data Sheet 947739	F Control, PVV-200/-250.... Data Sheet 947129
V-M Control, PVV-540	F Control, PVV-540
V-R Control, PVV-200/-250 ..Data Sheet 947738	P Control, PVV-200/-250 ... Data Sheet 947529
V-R Control, PVV-540	P Control, PVV-540.....
R Control, PVV-200/-250	
R Control, PVV-540.....	

“A-1 and A-2” Series Service Kits are included in:
 Bulletin 947029 for PVV-200/250 “A-1” Series Pump Service Instructions
 Bulletin 947028 for PVV-540 “A-1 and A-2” Series Pump Service Instructions

Safety First

Read and understand this entire instruction sheet before repairing or adjusting your Oilgear product.

Those who use and maintain this equipment must be thoroughly trained and familiar with the product. If incorrectly used or maintained, this product and its equipment can cause severe injury.

SAFETY SYMBOLS

The following signal words are used in this instruction sheet to identify areas of concern where your safety may be involved. Carefully read the text and observe any instructions provided to ensure your safety.

DANGER

THIS SIGNAL WORD INDICATES AN IMMEDIATELY HAZARDOUS SITUATION WHICH, IF NOT AVOIDED, WILL RESULT IN DEATH OR SERIOUS INJURY.

WARNING

This signal word indicates a potentially hazardous situation which, if not avoided, could result in death or serious injury.

CAUTION

This signal word indicates that a potentially hazardous situation exists which, if not avoided, may result in damage to equipment or minor personal injury.

NOTE

While not directly relevant to the topic being discussed, the NOTE is used to emphasize information provided, or provide additional information which may be of benefit.

WARNING

This service information is designed for the maintenance of your Oilgear product. It contains the information on the correct procedures determined by Oilgear for the safe manner of servicing. Always keep this instruction sheet in a location where it is readily available for the persons who use and maintain the product. Additional copies of this instruction sheet are available through Oilgear. Contact us at 414-327-1700 or visit our website: www.oilgear.com. Please contact us if you have any questions regarding the information in this instruction bulletin.

NOTE

The cleanliness of working on this pump control or the hydraulic system is extremely important to the safety and reliability of the pump and the system. Always make sure the fittings are clean on the outside before removing them from their connections, are capped and plugged when removed, and are placed in a clean rag or container until they are reinstalled.

WARNING

Some service operations may require special tools or equipment. If you require information on these items, please contact Oilgear before attempting these repairs and service operations.

WARNING

Read, understand and follow the safety guidelines, dangers and warnings contained in this instruction sheet to promote reliable operation and prevent serious personal injury.

WARNING

DO NOT attempt to service this machinery in an environment where safety regulations are not established and in place.

WARNING

DO NOT operate the hydraulic system if a leak is present. Serious injury may result.

WARNING

Hydraulic systems operate under very high pressure. Hydraulic fluid escaping from a pressurized system can penetrate unprotected body tissue. DO NOT inspect for hydraulic leaks with bare hands or other exposed body parts. As a minimum, wear leather gloves prior to inspecting for leaks and use cardboard or wood. If leaks are present, relieve pressure and allow system to cool prior to servicing. If injured by escaping hydraulic oil, contact a physician immediately. Serious complications may arise if not treated immediately. If you have questions regarding inspecting for hydraulic leaks, please contact Oilgear prior to servicing.

⚠ WARNING

Hydraulic hoses and tubing must be inspected on a daily basis for leaks, cuts, abrasions, damage and improper clearance along any mounting frame for hidden damage before the unit is put into service. Replace damaged hoses or hoses you suspect are damaged before the system is returned to service! Failure to properly inspect and maintain the system may result in serious injury.

⚠ WARNING

Hydraulic systems are hot. **DO NOT TOUCH!** Serious personal injury may result from hot oil. When you have completed working on the hydraulic system, thoroughly clean any spilled oil from the equipment. Do not spill any hydraulic fluids on the ground. Clean any hydraulic fluids from your skin as soon as you have completed maintenance and repairs. Dispose of used oil and system filters as required by law.

⚠ WARNING

Use hoses, fittings and adapters with the correct SAE rating when replacing hoses to prevent possible serious injury. Always replace hoses, fittings and adapters with replacements that have a proper, suitable, working pressure rating. Replacement hoses must be of the correct length and must comply with the hose manufacturer's and Oilgear's installation guidelines and recommendations.

⚠ WARNING

Hydraulic hoses have the SAE ratings marked on the hose to assist you in selecting the correct hose. The same manufacturer must supply any replacement hydraulic hoses and fitting assemblies. As an example: Brand "X" hose and brand "Y" fitting will not normally be compatible. No "Twist" is allowed in the hydraulic hoses. "Twist" may result in premature hose failure. This can cause serious injury. Please contact Oilgear for assistance when required.

⚠ WARNING

Hydraulic cylinders can be holding a function in a certain position when the pump is off. An example of this is a function being held in the lift or partial lift position by the cylinders. If a hydraulic line is removed or the hydraulic circuits or controls are being worked on, gravity may allow the function being held in position to drop. All workers and personnel must remain clear of these areas when working on or operating the hydraulic system. Block and secure all devices and functions which apply before beginning work or operation. Failure to comply with this can result in serious injury or death.

⚠ WARNING

Any hydraulic pipe which is replaced must conform to SAE J1065 specifications. If incorrect hydraulic pipe is installed, the hydraulic system may fail, causing serious injury. Damaged or leaking fittings, pipes or hoses must be replaced before the system is returned to service.

⚠ WARNING

DO NOT heat hydraulic pipe. The carbon content of this steel tube is such that if heated for bending, and either water or air quenched, the pipe may lose its ductility and thereby be subject to failure under high pressure conditions. Serious injury can result. Damaged or leaking pipes must be replaced before the system is returned to service. Please contact Oilgear if you require assistance or have questions.

⚠ WARNING

All hydraulic pressure must be relieved from the hydraulic system prior to removing any components from the system. To relieve the hydraulic pressure from the hydraulic system, turn off the motor and operate the control panel with the key in the ON position. Failure to comply can result in serious injury. If you have any questions concerning relieving the hydraulic pressure from the system, please contact Oilgear.

WARNING

Hydraulic components can be heavy. Use caution while lifting these components. Serious personal injury can be avoided with proper handling of the components.

WARNING

Please contact Oilgear if you require assistance. When performing hydraulic test procedures, use the proper hydraulic gauges. Installing an incorrect test gauge could result in serious injury if the gauge fails. Use properly rated hydraulic hoses to allow the test gauge to be read away from moving parts and functions.

WARNING

Increasing hydraulic pressure beyond the recommendations may result in serious damage to the pump and system or serious personal injury, and may void the Oilgear Warranty. If you have questions concerning hydraulic pressures or testing procedures, please contact Oilgear before attempting the test procedures or making adjustments.

WARNING

An Oilgear pump or pump control must not be modified in any way without authorization from Oilgear. Modifications may not comply with safety standards, including ANSI safety standards, and may result in serious personal injury. Please contact Oilgear if you require assistance.

WARNING

DO NOT enter under hydraulic-supported equipment unless it is fully supported or blocked. Failure to follow this procedure can result in serious injury or death.

WARNING

Any Oilgear pump safety decals must be replaced anytime they are damaged, missing or cannot be read clearly. Failure to have proper decals in place can result in serious injury or death. (If you require safety decals, please contact Oilgear for replacement safety decals, at no charge.)

WARNING

Be sure everyone is clear of the area around the hydraulic system before operating after servicing. Remain attentive at all times when operating to check your work until you are completely sure it is safe to return to service. Failure to heed this warning may result in serious personal injury or death.

WARNING

Wear the proper protective clothing when operating, servicing or maintaining the hydraulic system or the Oilgear pump. Wear the correct protective gear, safety glasses, gloves and safety shoes. Serious injury can result without proper protective gear.

WARNING

Make sure to keep hands, feet and other parts of your body clear of revolving or moving parts. Failure to comply can cause serious injury.

WARNING

DO NOT wear watches, rings or jewelry while working with electrical and mechanical equipment. These items can be hazardous and can cause serious and painful injuries if they come into contact with electrical wires, moving parts or hydraulic equipment.

PREPARATION AND INSTALLATION

MOUNTING

Pump Without Reservoir - The pump can be mounted in any position, but the recommended mounting position is with the driveshaft on a horizontal plane and with case "Port 1" to the top side. Secure the pump to a rigid mounting surface. Refer to **PIPING AND FITTINGS**.

Pump with Reservoir - These pumps are usually fully piped and equipped. It may be necessary to connect to a super-charge circuit when used. Mount reservoir on level foundation with the reservoir bottom at least 6 inches (152,4 mm) above floor level to facilitate fluid changes.

PIPING AND FITTINGS

Refer to the referenced Oilgear Piping Information Bulletin 90011 and individual circuit diagram before connecting the pump to the system. Inlet velocity must not exceed 5 fps (1,5 mps). Inlet should be unrestricted and have a minimum of fittings.

If "suction" inlet line is used, it should reach within 1 to 2 times its diameter from the bottom of reservoir. Suction inlet should be unrestricted and have a minimum of fittings. Please contact Oilgear for assistance or for recommendations.

NOTE *DO NOT use an inlet strainer.*

Horizontal Mounting - Arrange line from the "case drain" so the case remains full of fluid (non-siphoning). Case pressure must be less than 25 psi (1,7 bar). Each drain line must be a separate line, unrestricted, full sized and connected directly to the reservoir below the lowest fluid level. Make provisions for opening this line without draining (siphoning) reservoir.

Vertical Mounting - Refer to referenced Oilgear Installation of Vertically Mounted Axial Piston Units Bulletin 90014.

WARNING

Running the pump in NEUTRAL position (zero delivery) for extended periods can damage the pump. The system and pump must be protected against overloads by separate high-pressure relief valves. Install bleed valve(s) at the highest point(s) in system.

POWER

Power is required in proportion to volume and pressure used. Motor size recommendations for specific applications can be obtained from The Oilgear Company. Standard low starting torque motors are suitable for most applications.

CAUTION

DO NOT start or stop unit under load unless system is approved by Oilgear. It may be necessary to provide delivery bypass in some circuits.

DRIVE

Verify rotation direction plate on the pump's housing. Clockwise pumps must be driven clockwise and counterclockwise pumps must be driven counterclockwise. Use direct drive coupling. Size and install coupling per manufacturer's instructions.

CAUTION

DO NOT drive the coupling onto the pump driveshaft. If it is too tight, it may be necessary to heat coupling for installation. Refer to manufacturer's instructions.

Misalignment of pump shaft to driver's shaft should not exceed 0.005 inches (0,13 mm) Total Indicator Readout (TIR) in any plane.

FILTRATION

Keep the fluid clean at all times to ensure long life from your hydraulic system. Refer to the referenced Oilgear Filtration Recommendations Bulletin 90007 and Oilgear Contamination Evaluation Guide Bulletin 90004. Oilgear recommends use of a filter in an auxiliary (pilot) pump circuit. Replace filter element(s) when the filter condition indicator reaches change area at normal fluid temperature. Drain and thoroughly clean filter case. Use replacement element(s) of same beta 10 ratio ($B_{10}(c) = 200$).

FLUID COOLING

When the pump is operated continuously at the rated pressure or frequently at peak load, auxiliary cooling of the fluid may be necessary. Fluid temperature should not exceed limits specified in the referenced Oilgear Fluid Recommendations Bulletin 90000.

AIR BREATHER

On most installations, an air breather is mounted on top of fluid reservoir. It is important for the breather to be the adequate size to allow air flow in and out of reservoir as fluid level changes. Refer to the manufacturer's recommendations for air breather maintenance.

FLUID, FILLING AND STARTING RECOMMENDATIONS

Refer to instruction plate on the unit, reservoir, machine and/or reference Fluid Recommendations bulletin. Fire-resistant fluids and phosphate ester fluids can be used in accordance with fluid manufacturer's recommendations. Specialized fluids may require the pump to be ordered with special seals.

1. Pump all fluid into reservoir through a clean ($B_{10}(c) = 200$) filter. Fill reservoir to, but not above, "high level" mark on the sight gauge.
2. **Remove case drain line and fill pump case with hydraulic fluid.**

With pump under "no load" or with pump control at NEUTRAL:

3. Turn drive unit on and off several times before allowing pump to reach full speed. The system can usually be filled by running the pump and operating the control.
4. The fluid level in the reservoir will decrease as the system fills. **DO NOT** allow the fluid level to drop below the "low level" mark on the reservoir sight gauge. If the level reaches "low level" mark, add fluid and repeat step.

NOTE

With differential (cylinder) systems, the fluid must not be above "high level" when the ram is retracted or below "low level" when extended. Bleed air from the system by loosening connections or opening petcocks at the highest point in the system. Close connections or petcocks tightly when solid stream of fluid appears.

CONSTRUCTION

PVV-200/-250

See **Figures 3** and **4**

1. A driveshaft (**301**) runs through the center of the front (**001**) and middle (**002**) pump housing and valve plate (**401**).
2. The front driveshaft bearing (**302**) supports one end of the shaft and the rear shaft bearing (**403**) supports the other end of the shaft. A cylinder barrel (**101**) is splined to the driveshaft.
3. Pumping piston/shoe assemblies (**102**) in the cylinder are held against the swashblock wear plate (**202**) by a shoe retainer (**104**) and a shoe hold down retainer (**203**).
4. A cylinder spring (**105**), bearing against an inner cylinder spring guide (**106**) and driveshaft (**301**), acts against the outer cylinder spring guide (**107**) secured by screws (**110**) to the cylinder barrel (**101**), forcing the cylinder and wear plate (**103**) against the port plate (**1**) and valve plate (**401**).
5. The semi-cylindrical swashblock (**201**) can be swiveled in the saddle bearings (**204**) by operator pistons (**501**) which are operated by a control (covered in reference material).
6. A stroke indicator assembly (**811 through 816**) and stem (**812**) gives a visual indication of swashblock position.
7. The port plate (**1**) has two crescent shaped ports; one crescent connects the pumping pistons (**102**) to the pump inlet port. The other crescent port connects the pistons to the pump outlet port.

PVV-540

See **Figures 6** and **7**

1. A driveshaft (**301**) runs through the center of the front (**001**) and middle (**002**) pump housing and the valve plate (**401**).
2. The front driveshaft bearing (**302**) supports one end of the shaft and the rear shaft bearing (**403**) supports the other end of the shaft. A cylinder barrel (**101**) is splined to the driveshaft.
3. Pumping piston/shoe assemblies (**102**) in the cylinder are held against the swashblock wear plate (**202**) by a shoe retainer (**104**) and a hold down retainer (**203**).
4. A cylinder spring (**105**), bearing against an inner cylinder spring guide (**106**) and driveshaft (**301**), acts against the outer cylinder spring guide (**107**) and a retaining ring (**108**), which is placed into the cylinder barrel (**101**), forcing the cylinder and wear plate (**103**) against the port plate (**1**) and valve plate (**401**).
5. The semi-cylindrical swashblock (**201**) can be swiveled in the saddle bearings (**204**) by operator pistons (**501**), which are operated by a control (covered in reference material).
6. A stroke indicator assembly (**811 through 816**) and stem (**812**) gives a visual indication of the swashblock position.
7. The port plate (**1**) has two crescent shaped ports; one crescent connects the pumping pistons (**102**) to the pump inlet port. The other crescent port connects the pistons to the pump outlet port.

SPECIFICATIONS

NOTE

Refer to reference material, pump control material and individual application circuit for exceptions.

UNIT SIZE	THEORETICAL MAXIMUM DISPLACEMENT		RATED CONTINUOUS PRESSURE		PEAK PRESSURE		RATED FLOW AT CONTINUOUS RATED PRESSURE										MAXIMUM SPEED
							NON-SUPERCHARGED								SUPER-CHARGED		
							1000 rpm		1200 rpm		1500 rpm		1800 rpm		1800 rpm		
	in ³ /rev	ml/rev	psi	bar	psi	bar	gpm	lpm	gpm	lpm	gpm	lpm	gpm	lpm	gpm	lpm	
200	12.2	200	6000	414	6500	450	47	178	58	219	72	273	86	326	86	326	1800
250	15.26	250	5000	345	5800	400	59	223	72	273	91	344	109	413	109	413	1800
540	33.00	540	5000	345	5800	400	129	488	155	587	-	-	-	-	-	-	1200

Table 1. Rated Flow

UNIT SIZE	POWER INPUT AT CONTINUOUS RATED PRESSURE							
	1000 rpm		1200 rpm		1500 rpm		1800 rpm	
	hp	kw	hp	kw	hp	kw	hp	kw
200	185	138	223	166	278	208	330	246
250	203	152	242	180	302	225	362	270
540	460	343	547	408	-	-	-	-

Table 2. Power Input at Continuous Rated Pressure

UNIT	WIDTH		LENGTH		HEIGHT		WEIGHT		FACE MOUNTING FLANGE
	in.	mm	in.	mm	in.	mm	lb	kg	
PVV-200/-250	16.31	414,3	17.14	435,4	12.01	305,1	355	161	ISO 200 4-Bolt or SAE "E"
PVV-540	21.11	536,2	20.93	531,6	15.40	391,2	735	333	ISO 250 4-Bolt

For detailed dimensions, contact your Oilgear Representative.
Refer to installation drawings for more detailed dimensions and port configurations.

Table 3. Nominal Dimensions and Weights Without Controls

TROUBLESHOOTING

PROBLEM	CAUSES	REMEDY
Unresponsive or Sluggish Control	Faulty or binding control pistons.	Inspect. Clean out if contaminated.
	Insufficient control circuit pressure and/or volume.	Review control pressure/volume requirements.
	Swashblock (201) binding in saddle bearings (204).	Inspect components. Replace.
	Swashblock saddle bearings (204) worn.	
Insufficient Pump Volume	Delivery limited by faulty control.	See appropriate control instruction bulletin.
	Maximum volume stop (701) limiting pump stroke.	Adjust maximum volume stop.
	Obstructed suction circuit or insufficient supercharge volume.	Check for obstructions/review supercharge requirements.
	Insufficient drive motor speed.	Inspect components. Replace.
	Worn or grooved cylinder wear plate (103) and/or port plate (1).	
	Worn pistons/shoe assemblies (102) or piston bores (101).	
	Worn or damaged piston/shoe assemblies (102), swashblock (201) or swashblock wear plate (202).	
Irregular or Unsteady Operation	Fluid level in reservoir is low or supercharge is insufficient.	Verify fluid level and/or supercharge.
	Air entering hydraulic system.	Inspect system for leak.
	Faulty control - an oscillating stroke indicator stem (812) is indicative of an unstable control.	Inspect components. Replace.
	Worn axial piston pump.	
	Faulty output circuit components (cylinders, motors, valves, etc.).	
Loss of Pressure	Worn piston pump.	Inspect components. Replace.
	Worn or grooved cylinder wear plate (103) and/or port plate (1); wear plate and/or port plate separation from cylinder, each other or valve plate (401).	
	Worn pistons/shoes not seated on swashblock wear plate (202).	
	Faulty output circuit components.	
Excessive or High Peak Pressures	Faulty output circuit components.	Inspect components. Replace.
	Worn or broken saddle bearing.	
Excessive Noise	Pump incorrectly being stopped or started under load.	Verify operation procedure of pump.
	Low fluid level in reservoir or insufficient supercharge resulting in cavitation.	Verify fluid level.
	Air entering hydraulic system.	Inspect system for leak.
	Fluid too cold or viscosity too high.	Verify fluid temperature and type.
	Incorrect suction line configuration.	Inspect components. Replace.
	Broken or worn piston/shoe assembly (102).	
	Worn or pitted bearings (302, 004, 403).	
Pump rotating in wrong direction.	Inspect operation direction of pump.	
Excessive Heating	Operating pump above rated or peak pressure.	Verify pump limitations.
	Low fluid level in reservoir or insufficient supercharge.	Verify fluid level and/or supercharge.
	Air entering hydraulic system.	Inspect system for leak.
	Worn piston pump.	Inspect components. Replace.
	Worn or grooved cylinder wear plate (103) and/or port plate (1).	
	Faulty output circuit components.	
Insufficient cooling provision or clogged coolers.	Inspect for obstruction.	

DISASSEMBLY

Refer to **Figures 3 through 8** for your series of pump.

NOTE

Cleanliness when working on this pump or the hydraulic system is extremely important to the safety and reliability of the pump and the system.

When disassembling or assembling the pump, choose a clean, dry and dust- and sand-free area where no traces of abrasive particles are in the air which can damage the pump and system. DO NOT work near welding, sandblasting, grinding benches or similar conditions.

Always make sure the fittings are clean on the outside before removing them from their connections. Make sure they are capped and plugged when removed. Place them on a clean surface and in a clean rag or container until they are reinstalled. When cleaning parts which have been disassembled, it is important to use CLEAN cleaning solvents and allow parts to dry. All tools and gauges should be clean prior to working with the system and use new, CLEAN lint-free rags to handle and dry parts.

WARNING

DO NOT attempt to remove or install any components or assembly while the pump and system are running. Always stop the pump, shut OFF the power and release pressure from the system before servicing or testing. Be sure provisions have been made so the case drain line can be disconnected from the unit without causing the line to drain (siphon) the reservoir.

1. Disconnect case drain line(s), suction, pressure and all auxiliary lines.
2. Drain pump case. If pump case drain plugs are inaccessible, it may be necessary to remove the pump from the mounting and drive motor before draining it.

WARNING

Seek assistance from others and use a crane or hoist and proper lifting techniques to prevent personal injury.

NOTE

Tag similar parts (particularly screws, plugs and O-rings) during disassembly to make sure they don't become confused with similar parts and to ensure they will be returned to their original location. Do not remove (locator) roll pins unless they are deformed or need to be replaced.

3. After removing the pump from the mounting and before disassembly, cap or plug all ports and clean the outside of unit thoroughly to prevent contaminant from entering the system.

NOTE

Depending on what part or parts are to be inspected, it may not be necessary to completely take apart all assemblies. Review entire disassembly procedure before starting.

PVV-200/-250

Refer to **Figures 3 and 4**

If **only** the port plate **(1)** is to be inspected, it is possible to remove valve plate group only. The driveshaft group can be removed, without disassembling the rest of the pump, to access the front driveshaft bearing **(302)** and/or shaft seal **(007)**.

CONTROL GROUP

See reference material for information which applies to the control on your unit.

1. Remove screws **(508)** and the control cap assemblies **(503)** and identify from which bore (right or left side facing shaft) the control cap assembly **(503)** is removed.
2. When removing the control piston shoe assemblies **(501)**, identify from which bore (right or left side facing the driveshaft) each piston **(501)** and each control cap assembly **(503)** is removed.

STROKE INDICATOR GROUP

To disassemble the rotating group and/or swashblock group, it will be necessary to unscrew and remove the stroke indicator gland **(811)** and the stroke indicator assembly **(811 through 816)**.

DRIVESHAFT GROUP

1. Position pump vertically, with driveshaft (301) pointing up and block securely in place.
2. Alternately back out screws (307) partially to relax the cylinder spring (105) until they can be loosened by hand, and then remove.
3. Lift out shaft retaining plate (303). The driveshaft (301) can be pulled upward from the front pump housing.
4. Remove key (306) if used, and if necessary, the shaft bearing retaining ring (305) can be removed and front driveshaft bearing (302) pulled from shaft. The seal retainer (304) and shaft seal (007) can also be removed if necessary.

NOTE *If the seal is removed it cannot be reused. It must be replaced.*

FRONT HOUSING GROUP

CAUTION

Damage to the equipment or personal injury can occur. Use the eye bolts and a hoist to support the weight of front housing assembly (001).

1. Position the pump in a horizontal position.
2. Screw out swashblock pins (005) for the **PVV-200/-250** or pins (005 and 006) for the **PVV-540** with O-ring (012) from bottom and top of front pump housing (001). Discard O-ring.
3. Move back to vertical position.
4. Remove the screws (014) and lift off front pump housing (001). The swashblock (201) will remain with the rotating group.
5. Remove saddle bearings (204) from pins (016) and from the front housing (identify which saddle bearing is the top and which is the bottom so they are returned to the same position). Pin (017) will stay in the front (001) housing.
6. For the B1 series pumps only, lift out O-ring with backup ring (011) and remove pump housing gasket (003) and discard.

SWASHBLOCK GROUP

1. Remove the screws (210) which hold the swashblock (201) to swashblock wear plate (202).
2. Using the eyebolts and a hoist to support the swashblock (201), pry the swashblock from swashblock wear plate (202) and the rotating group assembly. If necessary, the stroke indicator dowel pin (215) and roll pin (211) can be removed. Screws (214) and control piston wear plates (213) can also be removed if necessary.

ROTATING GROUP

WARNING

The rotating group is heavy. Damage to the equipment or personal injury can occur. Be careful not to damage cylinder wear surface which mates against the valve plate, bearing diameters or piston shoes. Use proper lifting techniques and assistance from others to prevent personal injury.

1. Thread eyebolts into swashblock wear plate (202) and use a hoist to lift wear plate/piston assembly from the cylinder.
2. Remove screws (209) and pull swashblock wear plate (202) from assembly.
3. Lift out and identify each piston/shoe assembly (102) to the corresponding hole in the shoe retainer (104) and cylinder bore.
4. Remove the shoe retainer (104) and the shoe hold down retainer (203).

PVV-200/-250

5. Using the threaded lifting holes, lift the pump cylinder barrel (101) from the middle pump housing (002). If necessary, the cylinder wear plate (103) can be removed. Remove screws (110), the cylinder spring outer guide (107), the cylinder spring (105) and inner cylinder spring guide (106). If necessary, the locating pins (109) can also be removed.

The pump cylinder bearing (004) is a pressed fit, but can be tapped out from inside the middle housing (002) after the next step. Note the location of cylinder bearing locating pin (025) so it can be returned to the same location when unit is reassembled.

PVV-540

- Using the threaded lifting holes, lift the pump cylinder barrel (101) from the middle pump housing (002). If necessary, the cylinder wear plate (103), the retaining ring (108), the outer cylinder spring guide (107), the cylinder spring (105) and inner cylinder spring guide (106) can be removed. If necessary, the locating pins (109) can also be removed.

The pump cylinder bearing (004) is a pressed fit, but can be tapped out from inside the middle housing (002) after the next step. Note the location of cylinder bearing locating pins (025) so they can be returned to the same location when unit is reassembled.

MIDDLE HOUSING GROUP

NOTE Screws (405) are torqued to a high value. To prevent damage to the middle housing, the housing must be secured before removing the screws.

- Back out screw (405) and separate valve plate (401) from pump middle housing (002). Use a hoist to lift the middle housing (002) from the valve plate.
- For the B2 series only, lift out O-ring with backup ring (011) and remove pump housing gasket (003) and discard.

VALVE PLATE GROUP

CAUTION

Damage to the equipment or personal injury can occur. Use the eye bolts and a hoist to support the weight of the valve plate. Do not damage the faces of the port plate and the matching faces of both the valve plate and cylinder barrel.

If only the valve plate is being removed from the complete pump assembly, the cylinder spring (105) holds the pump cylinder (101) and its wear plate (103) against port plate (1). To avoid damage to these parts, back out the screws (405) partially on alternate corners, until they can be loosened by hand, then remove the valve plate (401).

PVV-200/250

If the middle housing group is removed, back out screws (405) and separate valve plate (401) from middle pump housing (002). If necessary, lift port plate (1) from locating pin (408) and valve plate (401). Do not remove the rear shaft bearing (403) unless replacement is necessary. If removed, note the direction the slot faces. Remove the O-rings (019) and (407) from housing and valve plate. Discard O-ring.

PVV-540

If the middle housing group is removed, back out screws (405) and separate valve plate (401) from pump middle housing (002). If necessary, remove screws (404) and lift port plate (1) from valve plate (401). Do not remove the rear shaft bearing (403) unless replacement is necessary. If removed, note the direction of the slot faces. Remove the O-rings (019) and (407) from housing and valve plate. Discard O-ring.

INSPECTION

Clean all parts thoroughly and allow them to dry. Inspect all seals and O-rings for hardening, cracking or deterioration. Replace if necessary or if you suspect damage. Check all locating pins for damage and springs for cracking, signs of cracking or signs of wear.

⚠ WARNING

Wear proper protective gear when using solvents or compressed air and when servicing or maintaining the hydraulic system or the Oilgear pump. Wear correct protective gear, safety glasses, gloves and safety shoes. Serious injury can result without proper protective gear.

CONTROL GROUP

See reference material for information that applies to the control on your unit. Be sure to carefully check control piston (501) for cracks and/or signs of excessive wear, making sure it does not bind in the control cap assembly (503). Make sure the control piston does not show signs of excessive wear and it slides smoothly in the control cylinder bore.

VALVE PLATE GROUP

Inspect the valve plate (401), port plate (1) and cylinder wear plate (103) surfaces which mate with each other, and the rear of the cylinder barrel (101) for excessive wear (scuffing and polishing are normal). If the mating surfaces are not flat and smooth, the cylinder will "lift off" from the port plate and cause delivery loss and damage to the pump. Remove minor defects by lightly stoning the surface with a hard stone which is flat to within 0.001 inches (0,025 mm).

NOTE *Be sure to stone lightly. Any excessive stoning will remove the hardened surface. If wear or damage is extensive, replace the component(s).*

STROKE INDICATOR GROUP

Check:

- the stroke indicator stem (812) slides smoothly in its gland (811).
- the spring (813) is not cracked, binding or broken.

ROTATING GROUP

Inspect cylinder barrel (101) piston bores and the face which mates with the cylinder wear plate (103) for wear and scoring. Remove minor defects on the face by lightly stoning or lapping the surface.

Inspect the hydrodynamic cylinder bearing (004) for damage and replace if necessary. Check all piston and shoe assemblies (102) to be sure they ride properly on the swashblock wear plate (202).

NOTE *Be sure to stone lightly. Any excessive stoning will remove the hardened surface. If wear or damage is extensive and defects cannot be removed, replace the cylinder barrel.*

See **Figure 2**. Check each shoe face for nicks and scratches, and the shoe for smooth pivot action on the piston.

NOTE *If one or more piston/shoe assembly needs to be replaced, replace all the piston/shoe assemblies. When installing new piston/shoe assemblies or the rotating group, make sure the pistons move freely in their respective bores.*

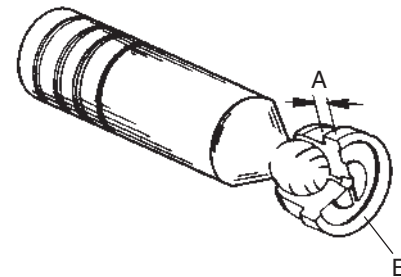

OILG-0005

Figure 2. Piston and Shoe Inspection

- (A) All shoes must be equal within 0.001 inches (0,025 mm) at this dimension.
- (B) All shoe faces must be free of nicks.

NOTE *End play should not to exceed 0.003 inches (0,076 mm) when new or 0.006 inches (0,152 mm) when worn.*

Inspect the cylinder bearing (004) and pump cylinder barrel (101) surfaces for galling, pitting or roughness, and replace if necessary.

SWASHBLOCK GROUP

Check:

- the swashblock wear plate (202) for scratches, grooves, cracks or uneven surfaces. The swashblock wear plate cannot be repaired if it is defective. It must be replaced.
- the saddle bearings (204) for evidence of tearing, wear-through or deterioration of bearing material.
- mating surface of swashblock for cracks or excessive wear; replace if necessary. The swashblock movement in saddle bearings (204) must be smooth.

DRIVESHAFT GROUP

Check:

- the shaft seal (007) for deterioration, cracks or its ability to seal. (It should hold its shape when it is pressed.) Replace if necessary (press-out).
- the shaft bearing (302) for galling, pitting, binding or roughness.
- the shaft and its splines for wear. Replace any parts necessary.

NOTE

If the driveshaft seal is removed, it cannot be reused. It must be replaced.

ASSEMBLY

NOTE

During reassembly, torque fasteners and plugs to specifications in Table 4. Refer to Table 4, Fastener and Plug Torque.

See Figures 3, 4 and 5 for PVV-200/-250 or Figures 6, 7 and 8 for PVV-540. Follow the disassembly procedures in reverse for re-assembling the pump.

During assembly, install new gaskets, seals and O-rings. Apply a thin film of CLEAN grease or hydraulic fluid to sealing components to ease assembly. If a new rotating group is used, lubricate thoroughly with CLEAN hydraulic fluid. Apply fluid generously to all wear surfaces.

VALVE PLATE GROUP AND MIDDLE HOUSING GROUP

WARNING

Avoid personal injury; use the eye bolts and a hoist to support the weight of the valve plate and seek assistance from others. Use proper lifting techniques.

CAUTION

Use extreme care not to damage the faces of the valve plate and matching faces of both the valve plate and cylinder barrel.

If gasket (903) is used, place new gasket on cover plate (901) and secure cover to valve plate (401) with screws (902).

1. Lay valve plate (401) on bench with machined surface facing up.
2. Press tailshaft bearing (403) into valve plate bore. When properly installed, bearing (403) **must protrude upward** 0.49 inches (12,4 mm) for the PVV-250/-250 or 0.60 inches (15,2 mm) for the PVV-540 from the machined face, with slot facing the same direction as original bearing.

NOTE

PVV-540 - Make sure the bearing (403) protrudes to the given dimension.

PVV-200/-250

3. Slide port plate (1) over tailshaft bearing to engage, locating dowel pin (408) which is pressed into valve plate.

PVV-540

3. Slide port plate (1) over tailshaft bearing and tap into position with a soft mallet. Position with shoulder screws (404); the screws should only position the port plate, not lock it tightly in position.

ALL UNITS

4. Install new O-ring (019) in groove on backside of pump middle housing (002).
5. Remove O-ring (407) in housing and discard; reinstall new O-ring.
6. Lubricate screws (405) and place in their respective bores in the valve plate before mounting valve plate. Secure valve plate (401) to middle pump housing (002). Torque screws (405) in an alternate and cross pattern to 240 ft-lb (325,4 N·m) for the PVV-200/-250 or 600 ft-lb (814 N·m) for the PVV-540.

NOTE

Final torquing may be easier after pump assembly is complete.

ROTATING GROUP

If locating pin (025) was removed, press locating pin into cylinder bearing (004) and slide or tap bearing into pump housing (002). Orient pin (025) to the same position it was in before disassembly.

1. Align the slots with screw holes in cylinder barrel and place the inner cylinder spring guide (106) with chamfered edge facing in, into the center bore of the pump cylinder (101). Follow the guide with the cylinder spring (105) and outer cylinder spring guide (107).

PVV-200/-250

2. Secure the assembly in the bore of pump cylinder (101) with screws (110).

PVV-540

2. Secure by snapping retaining ring (108) into groove in cylinder.

ALL UNITS

If locating pins (109) were removed, press locating pins into the rear end of the cylinder. Spread a coat of grease on the rear of the cylinder and locate cylinder wear plate (103) on the locating pins (109).

3. Lubricate port plate (1) and cylinder bearing (004) generously with hydraulic fluid. With middle pump housing (002) and valve plate (401) assembly on a bench, with the open end up, use eyebolts and a hoist to carefully lift cylinder (101) assembly up and carefully lower into bearing (004) and housing (002).
4. Place shoe hold down retainer (203) on bench blocks, insert the shoe retainer (104) with chamfered side down and lower each piston/shoe assembly (102) into its corresponding hole.

NOTE

A wooden frame with inside dimensions 8-1/4" x 8-1/4" x 5-1/2" deep for the PVV-540 and 6-1/4" x 6-1/4" x 5-1/2" deep for the PVV-200/-250.

5. Lubricate assembly liberally with hydraulic fluid.
6. Place swashblock wear plate (202), with locating pin (211) in it, on top of assembly and secure to hold down retainer (203) with new Nylock threaded screws (209). Make sure parts are centered, with outside diameters concentric before tightening screws (209). With screws (209) tightened, the pistons (102) and retainer (104) should rotate freely within the bolted wear plate (202) and hold down (203) assembly.
7. Place eyebolts in swashblock wear plate (202) and use a hoist to lift the assembly from the blocks. Make sure none of the pistons are binding in their shoes and swivel freely.
8. Lubricate bores in cylinder and the cylinder splines, and lower assembly slowly into pump case. Make sure pistons are returned to their original bores by working piston/shoe assemblies (102) into the cylinder while continuously lowering the wear plate assembly until the weight is no longer supported by the hoist.
9. Remove the eyebolts.
10. The locating pin (211) in the swashblock locates the position of the swashblock (201) on wear plate (202). Secure swashblock wear plate (202) with screws (210) to swashblock (201).

HOUSING GROUP

1. Place saddle bearing **(204)** on saddle bearing locating pins **(016)**. Make sure the locating pins' **(016)** inside diameters are clean and free of debris; they are a conduit for lubrication to the swashblock **(201)** and the swashblock liners **(204)**. If reinstalling original saddle bearings, make sure the one you identified for the "top" is returned to the upper location, and tap into place.
- 1a. If it was removed, a new roll pin **(017)** should be pressed into the front housing **(001)**.
2. B1 Series Only: Spread grease on housing surface and place a new pump housing gasket **(003)** and new O-ring with backup **(011)** in the pump front housing **(001)**.
B2 Series Only: Spread grease on housing surface and place a new pump housing gasket **(003)** and new O-ring with backup ring **(011)** in the pump middle housing **(002)**.
3. Using eyebolts and hoist, carefully lower pump front housing **(001)** onto the middle housing **(002)**. Make sure locating pin **(017)** engages mating hole in middle housing **(002)**. Simultaneously, the bearing **(004)** outside diameter must engage mating inside diameter in the front housing **(001)**, and the swashblock **(201)** liner races must engage the swashblock liner **(204)** cavity in the front housing **(001)**.

NOTE *At this point, there will still be a slight gap between the swashblock **(201)** and the swashblock liners **(204)**.*

ALL UNITS

4. Secure pump front housing **(001)** to middle pump housing **(002)** with screws **(014)** and torque to 110 ft·lb (149,1 N·m) for the **PVV-200/-250** or 240 ft·lb (325,1 N·m) for the **PVV-540**.

DRIVESHAFT GROUP

If seal **(007)** was removed, reinstall a new seal into the pump front housing **(001)** with "U" opening of the seal toward inside of housing. Press seal in until flush with top of seal gland.

1. Place seal retainer **(304)** over seal.
2. Press shaft bearing **(302)** onto driveshaft **(301)** and secure with retainer ring **(305)**.
3. Lubricate driveshaft **(301)** and lower the driveshaft so it passes through the front housing, cradle, cylinder barrel, cylinder wear plate, port plate and into the rear shaft bearing **(403)**. Gently rotate the driveshaft back and forth to help the splines on the driveshaft **(301)** engage the splines of the pump cylinder barrel **(101)**. The resistance of the cylinder spring **(105)** will keep the front driveshaft bearing **(302)** from seating completely in its bore.
4. Place shaft retainer plate **(303)** over front driveshaft bearing **(302)**.
5. Use screws **(307)** in an alternate cross pattern to "press" the retainer into its bore and compress the pump cylinder spring **(105)**. Continue to tighten screws **(307)** until it is firmly seated.
6. Insert eyebolts into the top-most, forward-most locations for bolts **(508)** in front housing **(001)** (one on each side of the pump). Lift pump just enough to tip to the horizontal position, then set pump back down on the bench.

SWASHBLOCK LOCATING PINS

PVV-200/-250

Place new O-rings **(012)** on the two swashblock locating pins **(005)** and make sure the swashblock is properly seated in the saddle bearings before installing the locating pins **(005)** into the front housing **(001)**.

It may be necessary to pull the swashblock toward the front of the pump to seat it against the saddle bearings, thus enabling the locating pins to be inserted. With the locating pins in place, the swashblock should swivel freely.

PVV-540

Place new O-rings **(012)** on the swashblock locating pins. The short pin **(005)** should be installed at the lower location on the front housing **(001)** and the longer pin **(006)** should be installed at the top location. Make sure the swashblock is properly seated in the saddle bearings before installing the locating pins.

It may be necessary to pull the swashblock toward the front of the pump to seat it against the saddle bearings, thus enabling the locating pins to be inserted. With the locating pins in place, the swashblock should swivel freely.

STROKE INDICATOR

1. Slide one backup ring **(816)**, a new O-ring **(815)** and second backup ring **(816)** onto stroke indicator stem **(812)**.
2. Slip stroke indicator spring **(813)** onto thinner end of stroke indicator stem.
3. Insert the smaller end of the stem assembly into the smaller end of the stroke indicator gland **(811)**. Install new O-ring **(814)** onto gland **(811)**.
4. Install gland assembly into same port on front housing **(001)** from which it was removed. Stem **(812)** must contact swashblock pin **(215)**.
5. Reach in through the control bores and swivel swashblock assembly to be sure the stroke indicator follows repositioning of the swashblock.

CONTROL GROUP

1. Remove O-rings **(009)** from front pump housing **(001)** and discard. Install new O-rings **(009)**.
2. Reinstall control piston/shoe assemblies **(501)** in the bores from which they were removed.
3. Use screws **(508)** to put control cap assemblies **(503)** back to the sides from which they were removed.

See reference material which applies to the control on your unit and appropriate control reference for control group mounting.

Unit Size	Fastener or Plug	Torque
PVV-200/-250	SCR, SHC, M16 X 120 MM LG. (014)	110 ft·lb (150 N·m)
	SCR, SHC, M5 X 20 MM LG, NYLOCK (110)	57 in·lb (6,5 N·m)
	SCR, SHC, M6 X 20 MM LG, NYLOCK (209)	87 in·lb (10 N·m)
	SCR, SHC, M5 X 40 MM LG, NYLOCK (210)	57 in·lb (6,5 N·m)
	SCR, SHC, M5 X 16 MM LG, NYLOCK (214)	57 in·lb (6,5 N·m)
	SCR, SHC, M8 X 25 MM LG. (307A)	15 ft·lb (20 N·m)
	SCR, SHC, M8 X 30 MM LG. (307B)	15 ft·lb (20 N·m)
	SCR, SHC, M20 X 75 MM LG. (405A)	240 ft·lb (325 N·m)
	SCR, SHC, M20 X 65 MM LG. (405B)	240 ft·lb (325 N·m)
	SCR, SHC, M6 X 20 MM LG. (902)	87 in·lb (10 N·m)
	SCR, SHC, M10 X 40 MM LG. (508)	35 ft·lb (47,5 N·m)
	1.25 BSP PLUG (015)	225 ft·lb (305 N·m)
	.375 BSP PLUG (028)	35 ft·lb (47,5 N·m)
	SAE #3 PLUG (030)	45 in·lb (5 N·m)
	SAE #4 PLUG (402 and 506)	120 in·lb (13,5 N·m)
	SAE #6 PLUG (519) B1	200 in·lb (23 N·m)
SAE #8 PLUG (026) and (519) B2	45 ft·lb (61 N·m)	
PVV-540	SCR, SHC, M20 X 160 MM LG. (014)	240 ft·lb (325 N·m)
	SCR, SHC, M6 X 25 MM LG, NYLOCK (209)	87 in·lb (10 N·m)
	SCR, SHC, M8 X 45 MM LG, NYLOCK (210)	15 ft·lb (20 N·m)
	SCR, SHC, M10 X 25 MM LG, NYLOCK (214)	35 ft·lb (47,5 N·m)
	SCR, SHC, M12 X 45 MM LG. (307)	68 ft·lb (92 N·m)
	SCR, SHLD, M10 X 16 MM LG. (404)	35 ft·lb (47,5 N·m)
	SCR, SHC, M24 X 100 MM LG. (405A)	600 ft·lb (814 N·m)
	SCR, SHC, M24 X 80 MM LG. (405B)	600 ft·lb (814 N·m)
	SCR, SHC, M6 X 20 MM LG. (902)	87 in·lb (10 N·m)
	SCR, SHC, M16 X 55 MM LG. (508)	138 ft·lb (187 N·m)
	1.50 BSP PLUG (015)	250 ft·lb (339 N·m)
	.375 BSP PLUG (028)	35 ft·lb (47,5 N·m)
	SAE #4 PLUG (030)	120 in·lb (13,5 N·m)
	SAE #6 PLUG (402 and 506)	200 in·lb (23 N·m)
	SAE #8 PLUG (026) and (519) B2	45 ft·lb (61 N·m)

Table 4. Fastener and Plug Torque

O-Ring Sizes
ARP 568 Uniform Size Number with Durometer

Item	Pump	
	PVV-200/-250	PVV-540
009	337-70	341-70
010	206-90	210-90
011	109-90*	114-90*
012	910-70	910-70
018	N/A	214-90
019	443-70	448-70
027	908-70	908-70
031	903-90	904-90
038	110-90	113-90
406	904-90	906-90
407	110-90	113-90
505	904-90	906-90
520	906-90	N/A
704	916-90	916-90
705	016-90	016-90
814	908-90	908-90
815	008-90	008-90

* Included in assembly with bronze backup ring

PARTS LIST

Parts used in these assemblies are per Oilgear specifications. Use only Oilgear parts to ensure compatibility with assembly requirements. When ordering replacement parts, be sure to include pump type and serial number, bulletin number and item number. Specify type of hydraulic fluid to assure seal and packing compatibility.

NOTE Parts drawings may not be identical to Oilgear drawings referenced.

Item	Qty.	Description
COMMON PARTS GROUP		
001	1	Housing, Pump, Front
002	1	Housing, Pump, Rear
003	1	Gasket, Pump Case
004	1	Bearing, Hydrodynamic
005	2	Pin, Swashblock - 200/250
	1	Pin, Swashblock, Lower - 540
006	1	Pin, Swashblock, Upper - 540
007	1	Seal, Shaft
008	2	Bolt, Lifting Eye
009	2	Seal, O-ring
010	8	Seal, O-ring - 200/250
	4	Seal, O-ring - 540
011	1	Seal, O-ring with Backup
012	2	Seal, O-ring
014	8	Screw
015	1	Plug, BSP
016	2	Pin, Roll
017	1	Pin, Roll
018	3	Seal, O-ring - 540
019	1	Seal, O-ring
020	8	Screw
021	1	Plate, Rotation Direction
023	1	Nameplate, Identification
024	1	Plate, Caution
025	1	Pin, Roll - 200/250
	2	Pin, Roll - 540
026	1	Plug, HP
027	1	Seal, O-ring
028	1	Plug, BSP
030	1	Plug, Edge Filter
031	1	Seal, O-ring
032	1	Plug, Orifice
034	2	Cover, Port
038	1	Seal, O-ring
050	1	Adapter, BSP to SAE (USA Pumps Only)

Parts are common between pumps. Only the differences are shown.

Item	Qty.	Description
ROTARY ASSEMBLY GROUP		
101	1	Cylinder Barrel
102	7	Assembly, Piston/Shoe - 200/250
	9	Assembly, Piston/Shoe - 540
103	1	Wear Plate, Cylinder
104	1	Retainer, Shoe
105	1	Spring, Cylinder
106	1	Spring Guide, Inner Cylinder
107	1	Retainer, Spring - 200/250
	1	Spring Guide, Outer Cylinder - 540
108	1	Retaining Ring - 540
109	2	Pin, Dowel
110	3	Screw - 200/250
SWASHBLOCK ASSEMBLY GROUP		
201	1	Swashblock
202	1	Wear Plate, Swashblock
203	1	Retainer, Hold Down Shoe
204	2	Liner, Swashblock
209	7	Screw - 200/250
	9	Screw - 540
210	2	Screw
211	1	Pin, Roll
213	2	Wear Plate, Control Piston/Shoe
214	8	Screw
215	1	Pin, Dowel
DRIVESHAFT ASSEMBLY GROUP		
301	1	Driveshaft
302	1	Bearing, Shaft
303	1	Plate, Retaining
304	1	Retainer, Seal
305	1	Ring, Special Retainer
306	1	Key, Shaft (keyed shafts only)
307	4	Screw
VALVE PLATE ASSEMBLY GROUP		
401	1	Valve Plate
402	2	Plug, HP
403	1	Bearing, Tailshaft
404	2	Screw, Shoulder - 540
405	4	Screw
406	2	Seal, O-ring
407	1	Seal, O-ring
408	1	Pin, Dowel - 200/250
	1	Pin, Roll - 540
STROKE INDICATOR ASSEMBLY GROUP		
811	1	Gland
812	1	Stem
813	1	Spring
814	1	Seal, O-ring
815	1	Seal, O-ring
816	2	Ring, Backup

Parts are common between pumps. Only the differences are shown.

Item	Qty.	Description
		COVER PLATE ASSEMBLY GROUP*
901	1	Cover Plate
902	4	Screw
903	1	Gasket
		PORT PLATE
1	1	Port Plate
		CONTROL CAPS
501	2	Assembly, Control Piston/Shoe
503	2	Assembly, Control Cap/Sleeve
505	4	Seal, O-ring - 200/250
	6	Seal, O-ring - 540
506	4	Plug, HP - 200/250
	6	Plug, HP - 540
508	8	Screw
519	2	Plug, HP - 200/250
520	2	Seal, O-ring - 200/250
		VOLUME STOPS
701	2	Stem
702	2	Gland
703	2	Locknut
704	2	Seal, O-ring
705	2	Seal, O-ring
706	2	Ring, Backup

Parts are common between pumps. Only the differences are shown.

* Cover plate assembly used on side-ported pumps only

SERVICE KITS

Service Kits for A Series Pumps are listed with the B Series Pump. Refer to Reference Information for A Series Bulletins.

PVV-200/-250 Basic Pump

Assembly drawings:
 517925 (A1)
 519104 (B1)
 519831 (B2)

Document Number: 519104-SK
 Revision: 1 (02/09)

Description	Kit No.	Design Series	Items Included (quantity is 1 unless noted)
Common Parts Kits			
Viton Seals, USA	K517925-002	A1	001, 002, 003, 004, 005(2), 007, 008(2), 009(2), 010(8), 011(3), 012(2), 013, 014(8), 015, 016(2), 017, 019, 020(8), 021, 023, 024, 025, 026, 027, 028, 029, 030(2), 031(2), 032, 033, 034(2), 035(2), 036(4)
Viton Seals, Metric	K517925-004	A1	001, 002, 003, 004, 005(2), 007, 008(2), 009(2), 010(8), 011(3), 012(2), 014(8), 015, 016(2), 017, 019, 020(8), 021, 023, 024, 025, 026, 027, 028, 030(2), 031(2), 032, 033, 034(2), 035(2), 036(4)
ISO Mount, Viton Seals, USA	K519104-001	B1	001, 002, 003, 004, 005(2), 007, 008(2), 009(2), 010(8), 011(3), 012(2), 014(8), 015, 016(2), 017, 019, 020(8), 021, 023, 024, 025, 026, 027, 028, 030, 031, 032, 034(2), 050
SAE Mount, Viton Seals, USA	K519104-003	B1	001, 002, 003, 004, 005(2), 007, 008(2), 009(2), 010(8), 011(3), 012(2), 014(8), 015, 016(2), 017, 019, 020(8), 021, 023, 024, 025, 026, 027, 028, 030, 031, 032, 034(2)
ISO Mount, Viton Seals, Metric	K519104-002	B1	001, 002, 003, 004, 005(2), 007, 008(2), 009(2), 010(8), 011(3), 012(2), 014(8), 015, 016(2), 017, 019, 020(8), 021, 023, 024, 025, 026, 027, 028, 030, 031, 032, 034(2)
SAE Mount, Viton Seals, Metric	K519104-004	B1	001, 002, 003, 004, 005(2), 007, 008(2), 009(2), 010(8), 011(3), 012(2), 014(8), 016(2), 017, 019, 020(8), 021, 023, 024, 025, 026, 027, 028, 030, 031, 032, 034(2), 050
ISO Mount, Viton Seals, USA	K519831-001	B2	001, 002, 003, 004, 005(2), 007, 008(2), 009(2), 010(8), 011(3), 012(2), 014(8), 016(2), 017, 019, 020(8), 021, 023, 024, 025, 026, 027, 028, 030, 031, 032, 034(2), 050
SAE Mount, Viton Seals, USA	K519831-003	B2	001, 002, 003, 004, 005(2), 007, 008(2), 009(2), 010(8), 011(3), 012(2), 014(8), 016(2), 017, 019, 020(8), 021, 023, 024, 025, 026, 027, 028, 030, 031, 032, 034(2)
ISO Mount, Viton Seals, Metric	K519831-002	B2	001, 002, 003, 004, 005(2), 007, 008(2), 009(2), 010(8), 011(3), 012(2), 014(8), 016(2), 017, 019, 020(8), 021, 023, 024, 025, 026, 027, 028, 030, 031, 032, 034(2)
SAE Mount, Viton Seals, Metric	K519831-004	B2	001, 002, 003, 004, 005(2), 007, 008(2), 009(2), 010(8), 011(3), 012(2), 014(8), 016(2), 017, 019, 020(8), 021, 023, 024, 025, 026, 027, 028, 030, 031, 032, 034(2)

PVV-200/-250 Basic Pump
Assembly drawings:
517925 (A1)
519104 (B1)
519831 (B2)

Document Number: 519104-SK
Revision: 1 (02/09)

Description	Kit No.	Design Series	Items Included (quantity is 1 unless noted)
Shaft & Bearing Kits (with Retainer & Bolts)			
USA			
1.97" Dia. Keyed (Code Y) T-S	K517925-301	A1	301, 302, 303, 304, 305, 306, 307
1.97" Dia. Keyed (Code Y)	K517925-302	A1	
2.00" Dia. Keyed (Code T) T-S	K517925-309	A1	
2.00" Dia. Keyed (Code T)	K517925-310	A1	
15T, 8/16 Spline (Code S) T-S	K517925-305	A1	301, 302, 303, 304, 305, 307
15T, 8/16 Spline (Code S)	K517925-306	A1	
Metric			
1.97" Dia. Keyed (Code Y) T-S	K517925-303	A1	301, 302, 303, 304, 305, 306, 307
1.97" Dia. Keyed (Code Y)	K517925-304	A1	
2.00" Dia. Keyed (Code T) T-S	K517925-311	A1	
2.00" Dia. Keyed (Code T)	K517925-312	A1	
15T, 8/16 Spline (Code S) T-S	K517925-307	A1	301, 302, 303, 304, 305, 307
15T, 8/16 Spline (Code S)	K517925-308	A1	
ISO Mount, USA & Metric			
1.97" Dia. Keyed (Code Y) T-S	K519104-301	B1 & B2	301, 302, 303, 304, 305, 306, 307
1.97" Dia. Keyed (Code Y)	K519104-302	B1 & B2	
1.75" Dia. Keyed (Code T) T-S	K519104-309	B1 & B2	
1.75" Dia. Keyed (Code T)	K519104-310	B1 & B2	
13T, 8/16 Spline (Code S) T-S	K519104-305	B1 & B2	301, 302, 303, 304, 305, 307
13T, 8/16 Spline (Code S)	K519104-306	B1 & B2	
SAE Mount, USA & Metric			
1.97" Dia. Keyed (Code Y) T-S	K519104-303	B1 & B2	301, 302, 303, 304, 305, 306, 307
1.97" Dia. Keyed (Code Y)	K519104-304	B1 & B2	
1.75" Dia. Keyed (Code T) T-S	K519104-311	B1 & B2	
1.75" Dia. Keyed (Code T)	K519104-312	B1 & B2	
13T, 8/16 Spline (Code S) T-S	K519104-307	B1 & B2	301, 302, 303, 304, 305, 307
13T, 8/16 Spline (Code S)	K519104-308	B1 & B2	
Shaft & Bearing Kits			
1.97" Dia. Keyed (Code Y) T-S	K517925-321	A1	301, 302, 304, 305, 306
1.97" Dia. Keyed (Code Y)	K517925-322	A1	
2.00" Dia. Keyed (Code T) T-S	K517925-329	A1	
2.00" Dia. Keyed (Code T)	K517925-330	A1	
1.97" Dia. Keyed (Code Y) T-S	K519104-321	B1 & B2	301, 302, 304, 305
1.97" Dia. Keyed (Code Y)	K519104-322	B1 & B2	
1.75" Dia. Keyed (Code T) T-S	K519104-329	B1 & B2	
1.75" Dia. Keyed (Code T)	K519104-330	B1 & B2	
15T, 8/16 Spline (Code S) T-S	K517925-325	A1	301, 302, 304, 305
15T, 8/16 Spline (Code S)	K517925-326	A1	
13T, 8/16 Spline (Code S) T-S	K519104-325	B1 & B2	
13T, 8/16 Spline (Code S)	K519104-326	B1 & B2	

T-S = Side ported with thru-shaft

PVV-200/-250 Basic Pump
Assembly drawings:
517925 (A1)
519104 (B1)
519831 (B2)

Document Number: 519104-SK
Revision: 1 (02/09)

Description	Kit No.	Design Series	Items Included (quantity is 1 unless noted)
Swashblock & Control Pin Kit			
USA	K517925-201	A1	201, 202, 203, 204(2), 209(7), 210(2), 211, 213(2), 214(8), 215
Metric	K517925-203	A1	
PVV200	K519104-202	B1 & B2	
PVV250	K519104-201	B1 & B2	
Swashblock Liners			
All	L319521	All	204(2)
Swashblock Wear Plate with Screws & Roll Pin			
USA	K408074-001	A1	202, 209(7), 210(2), 211
Metric	K408074-301	A1	
All		B1 & B2	
Control Piston Wear Plates with Screws			
USA	K251191-011	A1	213(2), 214(8)
Metric	K251191-001	A1	
All		B1 & B2	
Shoe Retainer & Hold-Down Ring with Screws			
PVV250, USA	K408072-000	A1	104, 203, 209(7)
PVV250, Metric	K408072-300	A1	
PVV200, USA	K408085-000	A1	
PVV200, Metric	K408085-300	A1	
All	K408085-004	B1 & B2	
Hydrodynamic Bearing Kit			
All	K319505	All	004, 025
Housing Gasket Kit			
All	K408124	A1	003, 011
All	K408124-001	B1 & B2	
Rotating Group			
PVV200, USA	K517925-101	A1	101, 102(7), 103, 104, 105, 106, 107, 109(2), 110(3)
PVV200, Metric	K517925-102	A1	
PVV250, USA	K517926-101	A1	
PVV250, Metric	K517926-102	A1	
PVV200	K519104-101	B1	
PVV250	K519104-102	B1	
PVV200	K519831-101	B2	
PVV250	K519831-102	B2	

PVV-200/-250 Basic Pump
Assembly drawings:
517925 (A1)
519104 (B1)
519831 (B2)

Document Number: 519104-SK
Revision: 1 (02/09)

Description	Kit No.	Design Series	Items Included (quantity is 1 unless noted)
Cylinder Barrel with Pins			
PVV200, USA	L517629-R11	A1	101, 109(2)
PVV200, Metric	L517629-311	A1	
PVV250, USA	L517614-R11	A1	
PVV250, Metric	L517614-311	A1	
PVV200	L517629-311	B1	
PVV250	L517614-002	B1	
PVV200	L517629-312	B2	
PVV250	L517614-005	B2	
Piston & Shoe Assembly			
PVV200	K319512-004	A1	102(7)
PVV250	K319502-004	A1	
PVV200	K319512-006	B1 & B2	
PVV250	K319502-006	B1 & B2	
Cylinder Wear Plate			
PVV200	517664-R01	A1 & B1	103
PVV250	517623-R01	A1	
PVV250	517623-004	B1	
PVV200	517664-001	B2	
PVV250	517623-010	B2	
Port Plate			
PVV200, Left-hand	517665-004	A1 & B1	Item 1
PVV200, Right-hand	517665-005	A1 & B1	
PVV250, Left-hand	517624-004	A1	
PVV250, Right-hand	517624-005	A1	
PVV250, Left-hand	517624-106	B1	
PVV250, Right-hand	517624-107	B1	
PVV200, Left-hand	517665-007	B2	
PVV200, Right-hand	517665-008	B2	
PVV250, Left-hand	517624-110	B2	
PVV250, Right-hand	517624-119	B2	

PVV-200/-250 Basic Pump
Assembly drawings:
517925 (A1)
519104 (B1)
519831 (B2)

Document Number: 519104-SK
Revision: 1 (02/09)

Description	Kit No.	Design Series	Items Included (quantity is 1 unless noted)
Valve Plate Kits			
PVV200, Rear Port, Viton, USA	K517925-407	A1	401, 402(4), 403, 405(4), 406(4), 407(2), 408
PVV200, Rear Port, Viton, Metric	K517925-415	A1	
PVV200, Side Port, Viton, USA	K517925-405	A1	
PVV200, Side Port, Viton, Metric	K517925-413	A1	
PVV250, Side Port, Viton, USA	K517926-405	A1	
PVV250, Side Port, Viton, Metric	K517926-413	A1	
Rear Port, Viton Seals, USA	K519104-402	B1	401, 402, 403, 405(4), 406, 407, 408
Rear Port, Viton Seals, Metric	K519104-404	B1	
Side Port, Viton Seals, USA	K519104-401	B1	401, 402(2), 403, 405(4), 406(2), 407, 408
Side Port, Viton Seals, Metric	K519104-403	B1	
Rear Port, Viton Seals, USA	K519831-402	B2	401, 402, 403, 405(4), 406, 407, 408
Rear Port, Viton Seals, Metric	K519831-404	B2	
Side Port, Viton Seals, USA	K519831-401	B2	401, 402(2), 403, 405(4), 406(2), 407, 408
Side Port, Viton Seals, Metric	K519831-403	B2	
Stroke Indicator			
Viton Seals	K519104-501	All	811, 812, 813, 814, 815, 816(2)
Basic Pump			
Viton Seals, USA	K517925-A01	A1	003, 007, 009(2), 010(8), 011(3), 012(2), 013, 019, 027, 029, 031(2), 406(4), 407(2), 505(4), 520(2), 704(2), 705(2), 706(2), 814, 815, 816(2), 903
Viton Seals, Metric	K517925-A03	A1	003, 007, 009(2), 010(8), 011(3), 012(2), 015, 019, 027, 028, 031(2), 406(4), 407(2), 505(4), 520(2), 704(2), 705(2), 706(2), 814, 815, 816(2), 903
Viton Seals, USA	K519104-A01	B1	003, 007, 009(2), 010(8), 011(3), 012(2), 015, 019, 027, 028, 031, 050, 406(2), 407, 505(4), 520(2), 704(2), 705(2), 706(2), 814, 815, 816(2), 903
Viton Seals, Metric	K519104-A11	B1	003, 007, 009(2), 010(8), 011(3), 012(2), 015, 019, 027, 028, 031, 406(2), 407, 505(4), 520(2), 704(2), 705(2), 706(2), 814, 815, 816(2), 903
Viton Seals, USA	K519831-A01	B2	003, 007, 009(2), 010(8), 011(3), 012(2), 019, 027, 028, 031, 050, 406(2), 407, 505(4), 520(2), 704(2), 705(2), 706(2), 814, 815, 816(2), 903
Viton Seals, Metric	K519831-A11	B2	003, 007, 009(2), 010(8), 011(3), 012(2), 019, 027, 028, 031, 406(2), 407, 505(4), 520(2), 704(2), 705(2), 706(2), 814, 815, 816(2), 903

PVV-200/-250 Basic Pump
Assembly drawings:
517925 (A1)
519104 (B1)
519831 (B2)

Document Number: 519104-SK
Revision: 1 (02/09)

Description	Kit No.	Design Series	Items Included (quantity is 1 unless noted)
Seal Kits for Options			
Cover Plate	319212	All	903
SAE A Adapter, Viton Seals	K319089-001	All	923, 924
SAE A-A Adapter, Viton Seals	K319089-002	All	
SAE B Adapter, Viton Seals	K319076-A05	All	
SAE C Adapter, Viton Seals	238270-049	All	923
Shaft Seal			
Viton Seals	251214	All	007
Driveshaft Bearing			
All	251185	All	302
Tailshaft Bearing			
All	215132-001	All	403
Cover Plate Kits			
USA	K517925-601	A1	901, 902(4), 903
Metric	K519104-601	A1	
All		B1 & B2	
Coupling & Adapter Kits			
SAE A, Viton, USA	K519104-622	All	921, 922, 923, 924, 925, 926(4) (plus 2 mtg. bolts & washers)
SAE A, Viton, Metric	K519104-632	All	
SAE A-A, Viton, USA	K519104-623	All	
SAE A-A, Viton, Metric	K519104-633	All	
SAE B, Viton, USA	K519104-624	All	921, 922, 923, 924, 925 (plus 2 mtg. bolts & washers)
SAE B, Viton, Metric	K519104-634	All	
SAE B-B, Viton, USA	K519104-625	All	
SAE B-B, Viton, Metric	K519104-635	All	
SAE C, Viton, USA	K519104-626	All	921, 922, 923 (plus 2 mtg. bolts & washers)
SAE C, Viton, Metric	K519104-636	All	
Nameplate & Screws			
All	233370-028	All	020(4), 023

PVV-540 Basic Pump
Assembly drawings:
515888 (A1)
518260 (A2)
519257 (B1)
519841 (B2)

Document Number: 519257-SK

Revision: 1 (02/09)

Description	Kit No.	Design Series	Items Included (quantity is 1 unless noted)
Common Parts Kits			
Viton Seals, USA	K518260-001	A2	001, 002, 003, 004, 005, 006, 007, 008(2), 009(2), 010(4), 011, 012(2), 013, 014(8), 015, 016(2), 017, 018(3), 019, 020(8), 021, 022, 023, 024, 025(2), 027, 033, 034(2), 035(4), 036(2), 037, 038(2), 039, 040(2), 041, 042, 043(2), 044, 045, 046
Viton Seals, Metric	K518260-002	A2	001, 002, 003, 004, 005, 006, 007, 008(2), 009(2), 010(4), 011, 012(2), 014(8), 015, 016(2), 017, 018(3), 019, 020(8), 021, 023, 024, 025(2), 026, 027, 028, 030, 031, 032, 034(2), 038(2), 050
ISO Mount, Viton Seals, USA	K519257-001	B1	001, 002, 003, 004, 005, 006, 007, 008(2), 009(2), 010(4), 011, 012(2), 014(8), 015, 016(2), 017, 018(3), 019, 020(8), 021, 023, 024, 025(2), 026, 027, 028, 030, 031, 032, 034(2), 038(2)
Viton Seals, Metric	K519257-002	B1	001, 002, 003, 004, 005, 006, 007, 008(2), 009(2), 010(4), 011, 012(2), 014(8), 015, 016(2), 017, 018(3), 019, 020(8), 021, 023, 024, 025(2), 026, 027, 028, 030, 031, 032, 034(2), 038(2), 050
ISO Mount, Viton Seals, USA	K519841-001	B2	001, 002, 003, 004, 005, 006, 007, 008(2), 009(2), 010(4), 011, 012(2), 014(8), 016(2), 017, 018(3), 019, 020(8), 021, 023, 024, 025(2), 026, 027, 028, 030, 031, 032, 034(2), 038(2), 050
Viton Seals, Metric	K519841-002	B2	001, 002, 003, 004, 005, 006, 007, 008(2), 009(2), 010(4), 011, 012(2), 014(8), 016(2), 017, 018(3), 019, 020(8), 021, 023, 024, 025(2), 026, 027, 028, 030, 031, 032, 034(2), 038(2)
Shaft & Bearing Kits			
2.48" Dia. Keyed (Code Y)	K518260-311	A1 & A2	301, 302, 304, 305, 306
2.48" Dia. Keyed (Code Y) T-S	K518260-312	A1 & A2	
2.50" Dia. Keyed (Code T)	K518260-315	All	
2.50" Dia. Keyed (Code T) T-S	K518260-316	All	
2.48" Dia. Keyed (Code Y)	K519257-312	B1 & B2	
2.48" Dia. Keyed (Code Y) T-S	K519257-311	B1 & B2	
29T, 12/24 Spline (Code S)	K519257-314	B1 & B2	301, 302, 304, 305
29T, 12/24 Spline (Code S) T-S	K519257-313	B1 & B2	

T-S = Side ported with thru-shaft

PVV-540 Basic Pump
Assembly drawings:
515888 (A1)
518260 (A2)
519257 (B1)
519841 (B2)

Document Number: 519257-SK

Revision: 1 (02/09)

Description	Kit No.	Design Series	Items Included (quantity is 1 unless noted)
Shaft & Bearing Kits (with Retainer & Bolts)			
USA			
2.48" Dia. Keyed (Code Y)	K518260-301	A1 & A2	301, 302, 303, 304, 305, 306, 307
2.48" Dia. Keyed (Code Y) T-S	K518260-302	A1 & A2	
2.50" Dia. Keyed (Code T)	K518260-305	A1 & A2	
2.50" Dia. Keyed (Code T) T-S	K518260-306	A1 & A2	
Metric			
2.48" Dia. Keyed (Code Y)	K518260-303	A1 & A2	301, 302, 303, 304, 305, 306, 307
2.48" Dia. Keyed (Code Y) T-S	K518260-304	A1 & A2	
2.50" Dia. Keyed (Code T)	K518260-307	A1 & A2	
2.50" Dia. Keyed (Code T) T-S	K518260-308	A1 & A2	
USA & Metric			
2.48" Dia. Keyed (Code Y)	K518260-307	B1 & B2	301, 302, 303, 304, 305, 306, 307
2.48" Dia. Keyed (Code Y) T-S	K518260-308	B1 & B2	
2.50" Dia. Keyed (Code T)	K519257-302	B1 & B2	
2.50" Dia. Keyed (Code T) T-S	K519257-301	B1 & B2	
29T, 12/24 Spline (Code S)	K519257-304	B1 & B2	301, 302, 303, 304, 305, 307
29T, 12/24 Spline (Code S) T-S	K519257-303	B1 & B2	
Swashblock Kits			
USA	K515888-201	A1	201, 202, 203, 204(2), 205(2), 206(2), 207(2), 208, 209(9), 210(2), 211, 212
Metric	K515888-202	A1	
USA	K518260-201	A2	201, 202, 203, 204(2), 205(2), 206(2), 208, 209(9), 210(2), 211, 212
Metric	K518260-202	A2	
Left Hand (CCW) Rotation	K519257-201	B1 & B2	201, 202, 203, 204(2), 209(9), 210(2), 211, 213(2), 214(8), 215
Right Hand (CW) Rotation	K519257-202	B1 & B2	
Swashblock Liners			
All	L407773	All	204(2)6
Swashblock Wear Plate with Screws & Roll Pin			
USA	K515881-003	A2	202, 209(9), 210(2), 211
Metric	K515881-303	A2	
All	K515881-330	B1	
All	K515881-335	B2	
Control Piston Wear Plates with Screws			
All	K251541	B1 & B2	213(2), 214(8)
Shoe Retainer & Hold-Down Ring with Screws			
USA	K515882-000	A1 & A2	104, 203, 209(9)
Metric	K515882-300	A1 & A2	
All	K515882-300	B1 & B2	
Hydrodynamic Bearing Kit			
All	K318912	All	004, 025(2)
Housing Gasket Kit			
All	K407772	A1 & A2	003, 011, 037
All	K407772-001	B1 & B2	003, 011

T-S = Side ported with thru-shaft

PVV-540 Basic Pump
Assembly drawings:
515888 (A1)
518260 (A2)
519257 (B1)
519841 (B2)

Document Number: 519257-SK

Revision: 1 (02/09)

Description	Kit No.	Design Series	Items Included (quantity is 1 unless noted)
Rotating Group			
All	K518260-111	A1 & A2	101, 102(9), 103, 104, 105, 106, 107, 108, 109(2)
All	K519257-111	B1	
All	K519841-101	B2	
Cylinder Barrel with Pins			
All	L515718	A1 & A2	101, 109(2)
All	L515718-301	B1 & B2	
Piston & Shoe Assembly			
All	K318923-006	A1, A2, B1	102(9)
All	K318923-018	B2	
Cylinder Wear Plate			
All	515880	A1 & A2	103
All	515880-001	B1 & B2	
Port Plate Kits			
Left-hand, USA	K723635	A1 & A2	Item 1, 404(2)
Right-hand, USA	K723635-001	A1 & A2	
Left-hand, Metric	K723635-300	A1 & A2	
Right-hand, Metric	K723635-301	A1 & A2	
Left-hand	K723635-307	B1	
Right-hand	K723635-308	B1	
Left-hand	K723635-322	B2	
Right-hand	K723635-318	B2	
Valve Plate Kits			
Rear Port, Viton Seals, USA	K515888-401	A1	401, 402(3), 403, 404(2), 405(4), 406(3), 407(2)
Rear Port, Viton Seals, Metric	K515888-403	A1	
Side Port, Viton Seals, USA	K515888-402	A1	401, 402, 403, 404(2), 405(4), 406
Side Port, Viton Seals, Metric	K515888-404	A1	
Rear Port, Viton Seals, USA	K518260-401	A2	401, 402(4), 403, 404(2), 405(4), 406(4), 407(2), 410
Rear Port, Viton Seals, Metric	K518260-403	A2	
Side Port, Viton Seals, USA	K518260-402	A2	401, 402(3), 403, 404(2), 405(4), 406(3), 407(2), 408, 409, 410
Side Port, Viton Seals, Metric	K518260-404	A2	
Side Port, Viton Seals, USA	K519257-401	B1 & B2	401, 402(2), 403, 404(2), 405(4), 406(2), 407, 408
Side Port, Viton Seals, Metric	K519257-403	B1 & B2	
Rear Port, Viton Seals, USA	K519257-402	B1 & B2	401, 402, 403, 404(2), 405(4), 406, 407, 408
Rear Port, Viton Seals, Metric	K519257-404	B1 & B2	
Stroke Indicator			
Viton Seals	K518260-812	A1 & A2	801, 802, 803, 804, 805, 806, 807, 808, 809
Viton Seals	K519257-501	B1 & B2	811, 812, 813, 814, 815, 816(2)

PVV-540 Basic Pump
Assembly drawings:
515888 (A1)
518260 (A2)
519257 (B1)
519841 (B2)

Document Number: 519257-SK

Revision: 1 (02/09)

Description	Kit No.	Design Series	Items Included (quantity is 1 unless noted)
Basic Pump Seal Kits			
Viton Seals	K515888-A11	A1	003, 007, 009(2), 010(4), 011, 012(2), 013, 018(3), 019, 028, 037, 038, 207(2), 407(2), 505(9), 704(2), 705(2), 706(2), 804, 805, 903
Viton Seals	K518260-A21	A2	003, 007, 009(2), 010(4), 011, 012(2), 013, 018(3), 019, 028(2), 037, 038(2), 039, 040(3), 207(2), 407(2), 505(12), 704(2), 705(2), 706(2), 804, 805, 903
Viton Seals, USA	K519257-A01	B1	003, 007, 009(2), 010(4), 011, 012(2), 015, 018(3), 019, 027(2), 028, 031, 050, 407(3), 505(9), 704(2), 705(2), 706(2), 815, 816(2), 903
Viton Seals, Metric	K519257-A11	B1	003, 007, 009(2), 010(4), 011, 012(2), 015, 018(3), 019, 027(2), 028, 031, 407(3), 505(9), 704(2), 705(2), 706(2), 815, 816(2), 903
Viton Seals, USA	K519841-A01	B2	003, 007, 009(2), 010(4), 011, 012(2), 018(3), 019, 027(2), 028, 031, 050, 407(3), 505(9), 704(2), 705(2), 706(2), 815, 816(2), 903
Viton Seals, Metric	K519841-A11	B2	003, 007, 009(2), 010(4), 011, 012(2), 018(3), 019, 027(2), 028, 031, 407(3), 505(9), 704(2), 705(2), 706(2), 815, 816(2), 903
Seal Kits for Options			
Cover Plate	319212	All	903
SAE B Adapter, Viton Seals	K319076-A05	All	923, 924
SAE C Adapter, Viton Seals	238270-049	All	923
Shaft Seal			
Viton Seals	250486-001	All	007
Driveshaft Bearing			
All	250487	All	302
Tailshaft Bearing			
All	250797	All	403
Coverplate Kits			
USA	K518260-901	A1 & A2	901, 902(4), 903
Metric	K519257-601	A1 & A2	
All	K519257-601	B1 & B2	
Coupling & Adapter Kits			
SAE B, Viton, USA	K519257-622	All	921, 922, 923, 924, 925 (plus 2 mtg. bolts & washers)
SAE B, Viton, Metric	K519257-632	All	
SAE C, Viton, USA	K519257-623	All	921, 922, 923 (plus 2 mtg. bolts & washers)
SAE C, Viton, Metric	K519257-633	All	
Nameplate & Screws			
All	K312665-001	All	020(4), 023

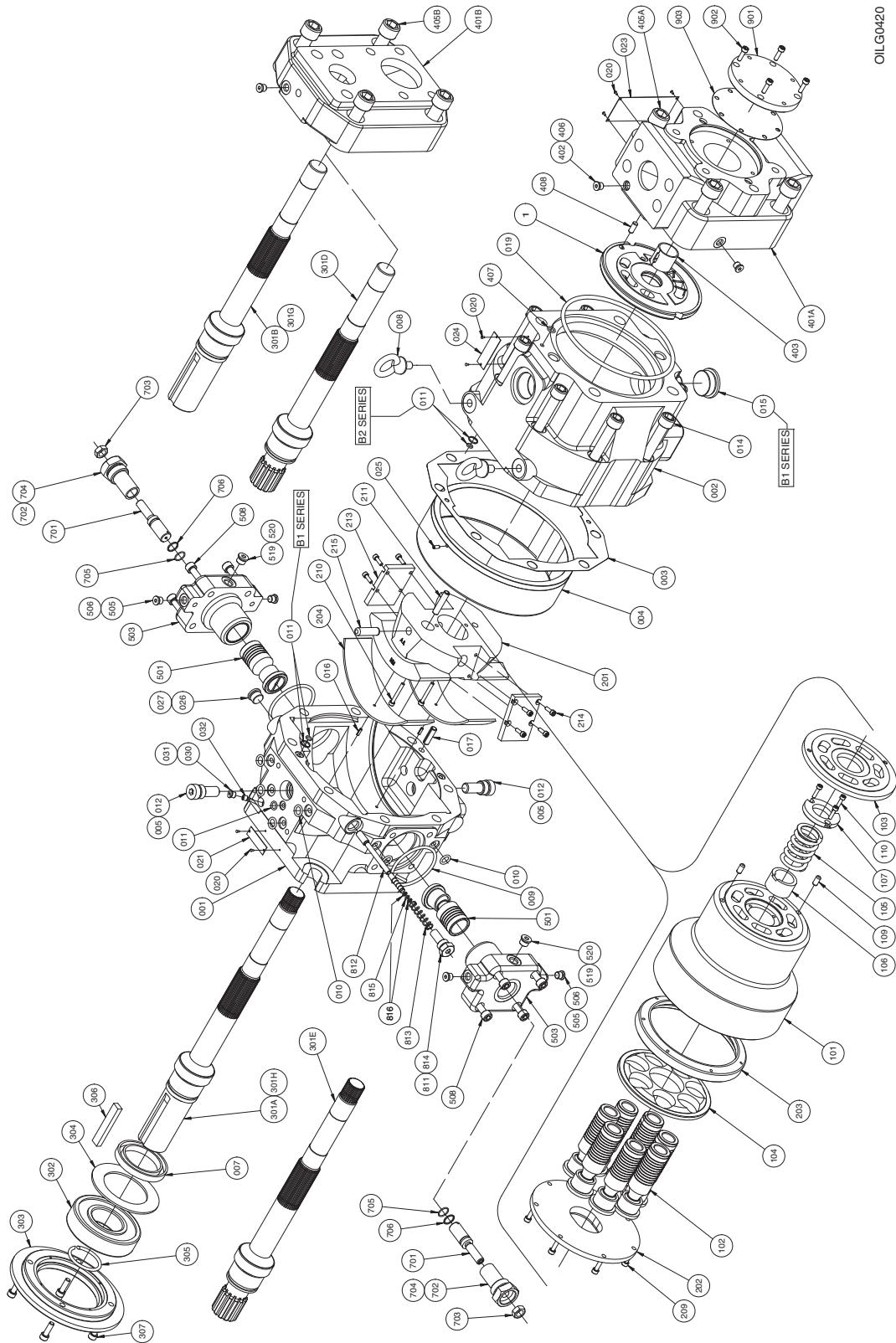

OILG0420

**Figure 3. Exploded Parts Drawing for PVV-200/-250 B1 and B2
(B1 519104 sheet 2, B2 519831 sheet 2)**

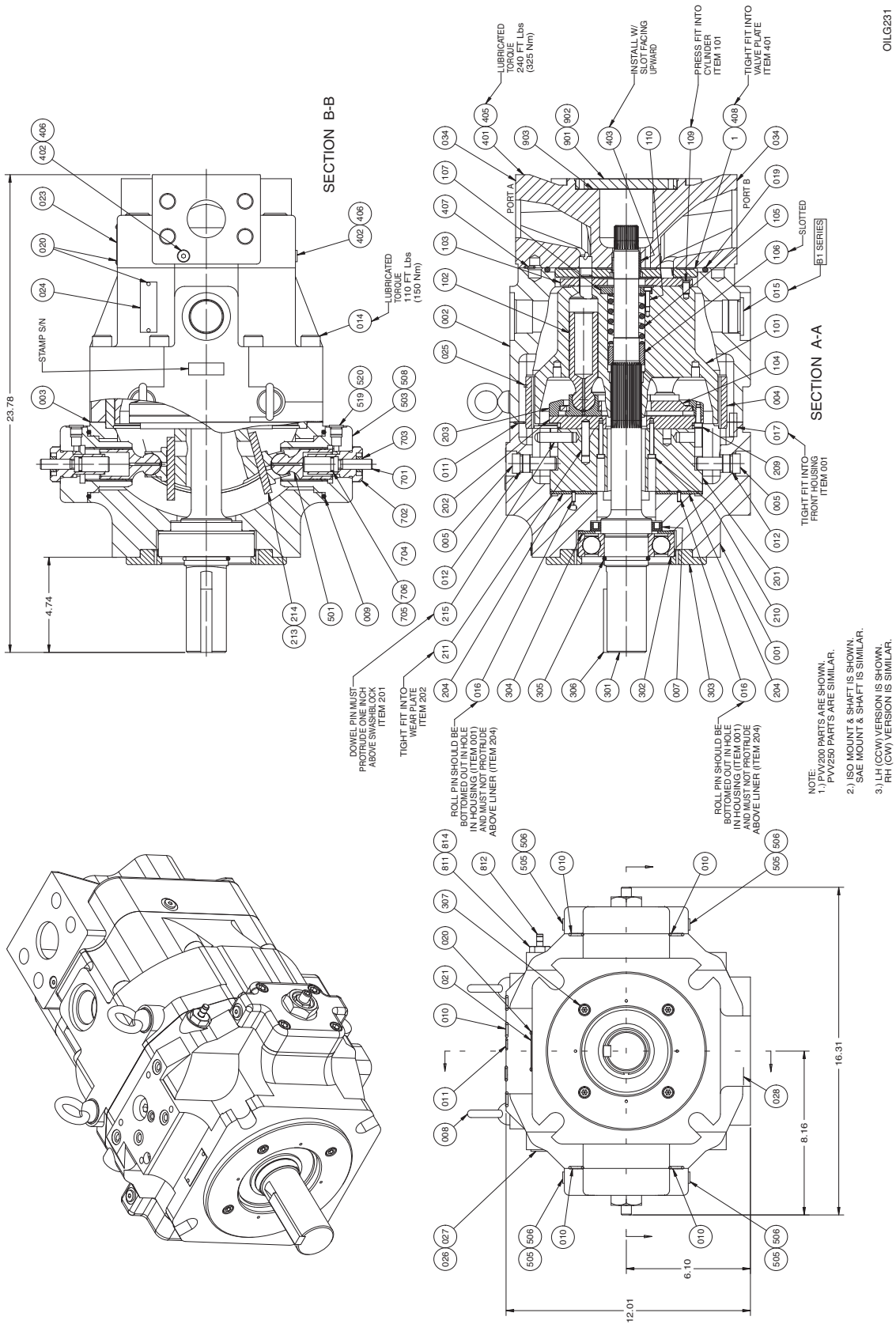

Figure 4. Exploded Parts Drawing for PVV-200/-250 B1 and B2
(PVV-200 shown [B1 519104 sheet 1, B2 519831 sheet 1])

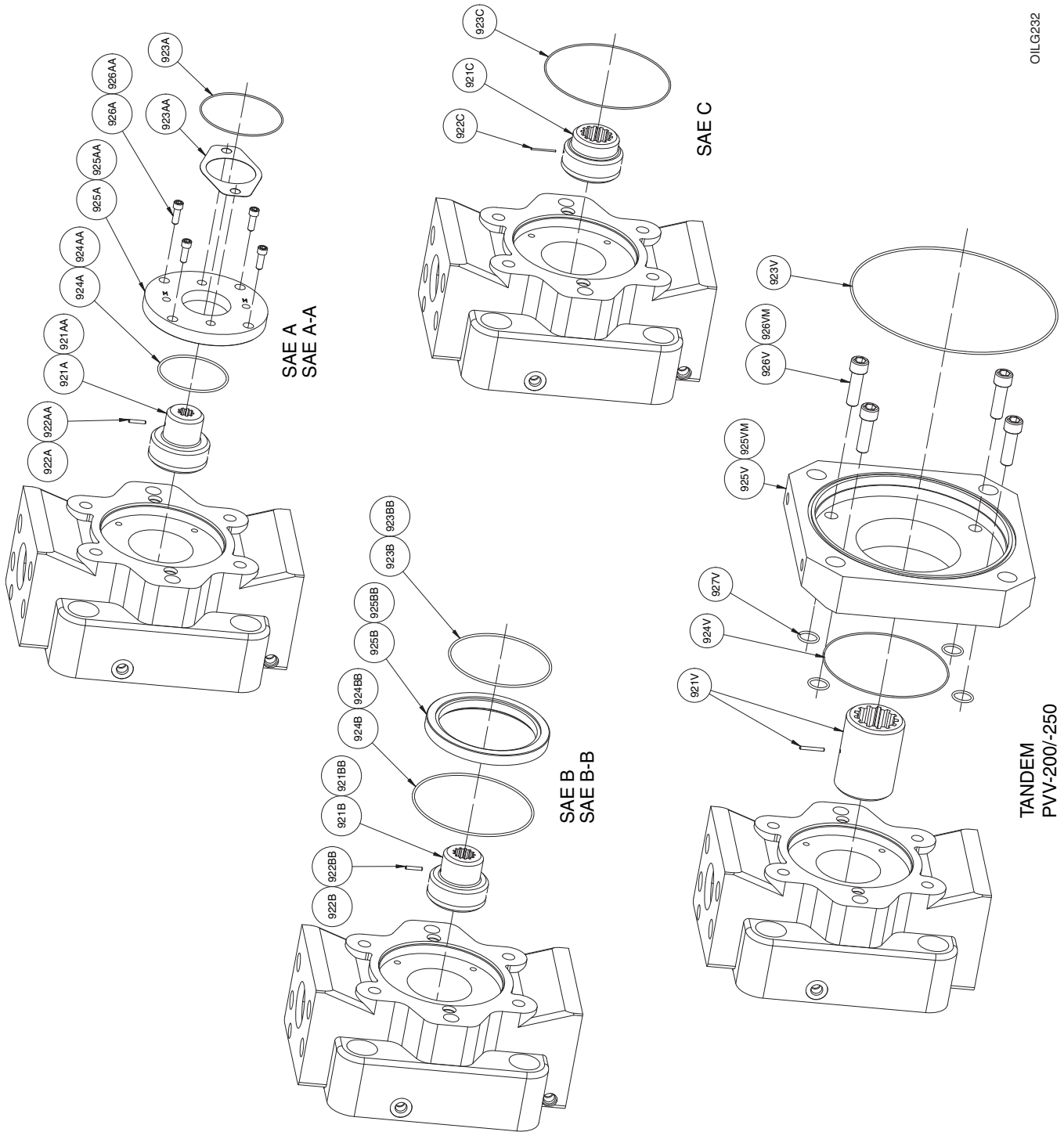
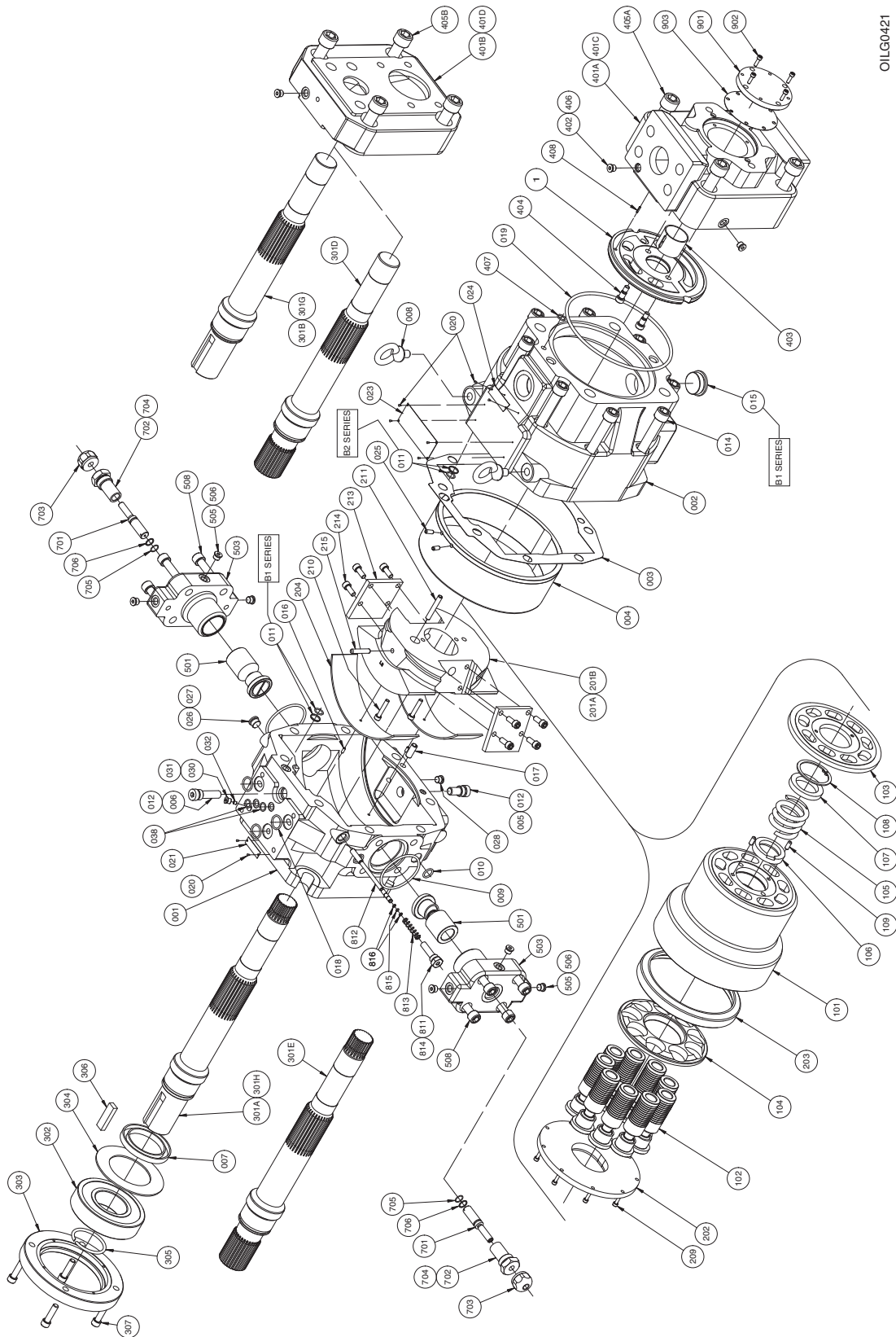

Figure 5. Adapter and Coupling Assemblies for PVV-200/-250 B1 and B2 (B1 519104 sheet 4, B2 519831 sheet 4)
The SAE adapters are designed to mount splined, 2-bolt pumps only to the back of PVV-200/-250 pumps.



OILG0421

**Figure 6. Exploded Parts Drawing for PVV-540 B1 and B2
(LH [CCW] rotation is shown [B1 519257 sheet 2, B2 519841 sheet 2])**

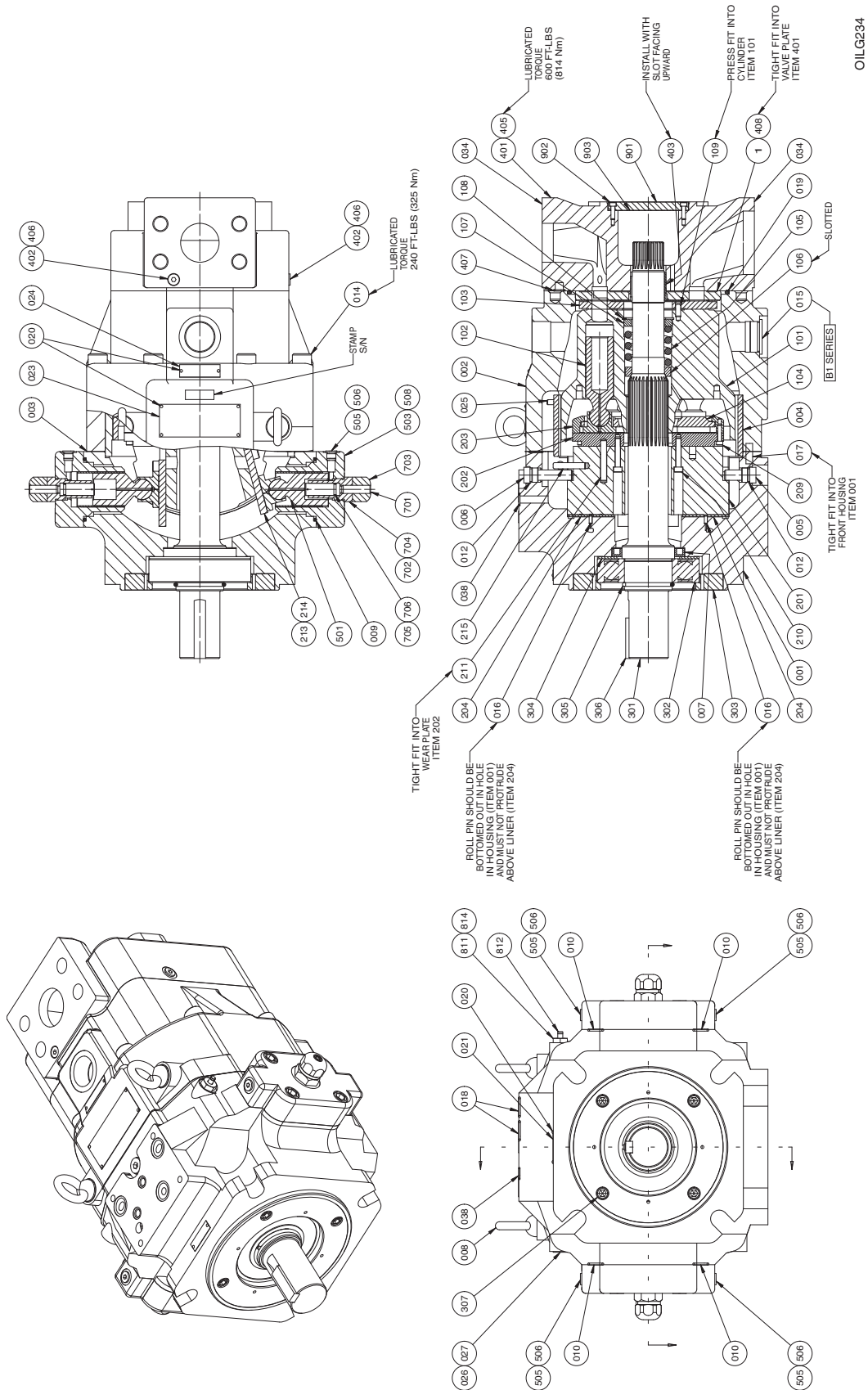

Figure 7. Exploded Parts Drawing for PVV-540 B1 and B2 (B1 519257 sheet 1, B2 519841 sheet 1)

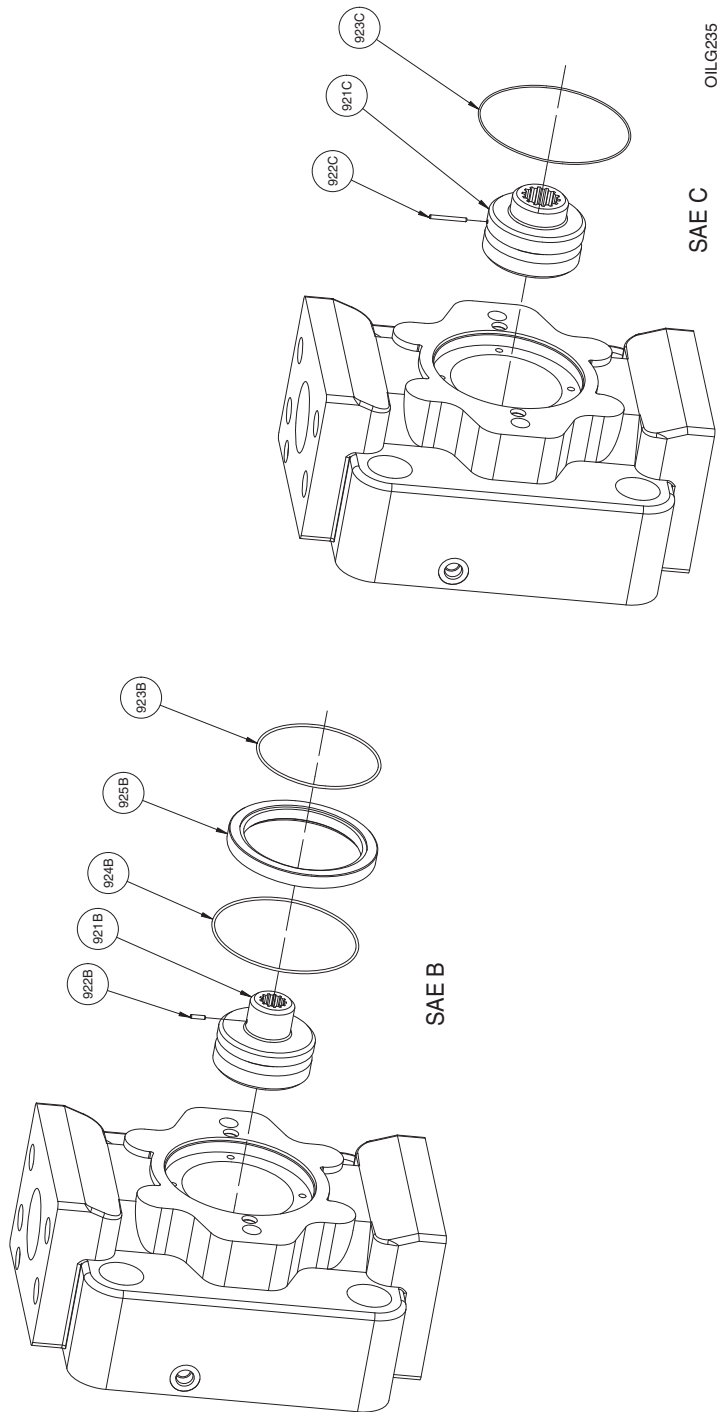

Figure 8. Adapter and Coupling Assemblies for PVV-540 B1 and B2 (B1 519257 sheet 4, B2 519841 sheet 4)
The SAE adapters are designed to mount splined, 2-bolt pumps only to the back of PVV-540 pumps.

AFTER SALES SERVICES

At Oilgear we build products to last. It is the nature of this type of machinery to require proper maintenance regardless of the care we put into manufacturing. Oilgear has several service programs in place to help you.

STAY-ON-STREAM SERVICE

By signing up for Oilgear's Stay-On-Stream program, you can prepare for problems before they happen. Certain field tests such as fluid testing, slip testing and electronic profile recording comparisons can be performed by our field service people or your own factory trained personnel. These tests can indicate problems before they become "down-time" difficulties.

SERVICE SCHOOLS

Oilgear conducts training to train your maintenance personnel. "General" hydraulic or electronic training is conducted at our Milwaukee, Wisconsin plant on a regular basis. "Custom" training, specifically addressing your particular hydraulic and electro-hydraulic equipment can be conducted at your facilities.

SPARE PARTS AVAILABILITY

Prepare for your future needs by stocking Oilgear original factory parts. Having the correct parts and necessary skills "in-plant" enables you to minimize "down-time." Oilgear has developed parts kits to cover likely future needs. Oilgear Field Service Technicians are also ready to assist you and your maintenance people in troubleshooting and repairing equipment.

