

# OILGEAR TYPE "DHH" PUMPS

TYPE DHH  
DUAL GEAR PUMP

\*ITEMS 16 & 117 ARE FURNISHED  
ONLY AS COMPLETE ASSEMBLY.

\*ITEMS 73 & 74 ARE FURNISHED  
ONLY AS COMPLETE ASSEMBLY.

NOTE:  
WHEN ORDERING PARTS BE SURE TO  
GIVE SERIAL NUMBER STAMPED ON  
NAMEPLATE.

16669	DRAWING
OILGEAR TYPE "DHH" PUMPS	PART SLIP
CH. 27	3A
APP. 27	SLIP

ISSUED 12/15/56

THE OILGEAR COMPANY  
MILWAUKEE 4, WISCONSIN, U.S.A.

DS-947450

39991

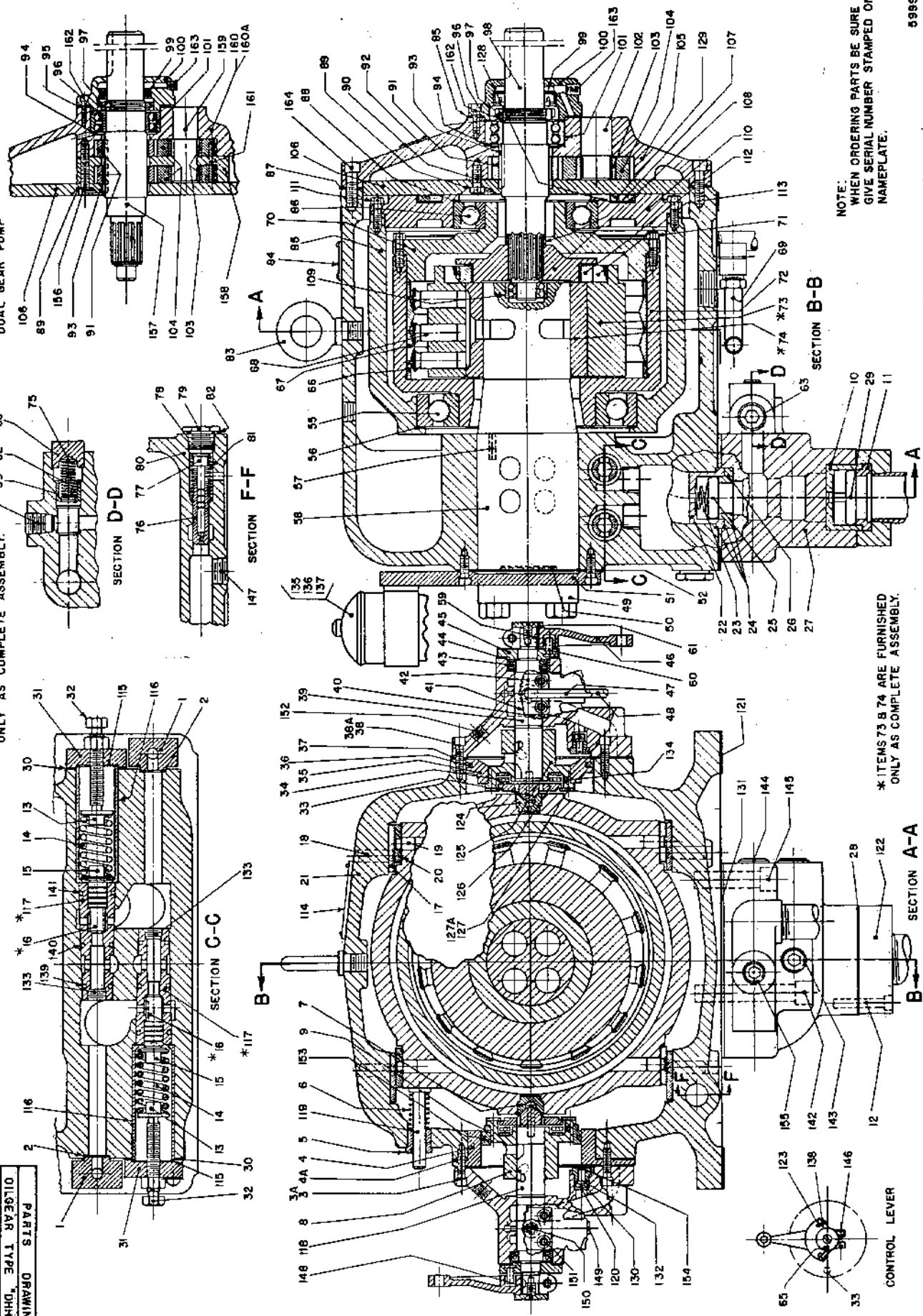

## PARTS LIST

OILGEAR TYPE "DHH" PUMPS

Sheet 1 of 1 Sheet

## RECORD

No.	PART	NO.	PART	NO.	PART
1.	Flange, Auxiliary	52.	Gasket, Pintle Cover	106.	Cover, Gear Pump
2.	Gasket, Flange	53.	Plunger, B.P.R.V.	107.	Spacer, Coupling
3.	Housing, Fast Control	54.		108.	Flange, Coupling
3A.	Screw, Sock. Hd. Cap	55.	Bearing, Rear Rotor	109.	Bearing, Rear Shaft
4.	Adapter, Control Piston	56.	Shim, Rear Rotor Bearing	110.	Cover, Slide Block
4A.	Gasket, Adapter	57.	Key, Pintle	111.	Screw, Slide Block Cover
5.	Bushing, Indicator	58.	Pintle	112.	Ring, Coupling
6.	Spring, Indicator	59.	Key, Woodruff	113.	Roller, Coupling
7.	Cup, Thrust	60.	Pin, Stop	114.	Plate, Instruction
8.	Sleeve, Fast Control	61.	Washer, Retainer	115.	Shim, H.P.R.V. Retainer
9.	Piston, Small Control	62.	Spring, B.P.R.V.	116.	Bushing, Retainer
10.	Cage, Check Valve	63.	Cover, B.P.R.V.	*117.	Bushing, H.P.R.V.
11.	Seat, Check Valve	64.	Plug, Pipe	118.	Plunger, Control
12.	Screw, Hex. Head, Cap	65.	Pin, Retainer Washer	119.	Stem, Indicator
13.	Guide, H.P.R.V. Spring	66.	Ring, Spacer	120.	Cage, Check Valve
14.	Spring, H.P.R.V.	67.	Ring, Thrust	121.	Gasket, Pump Mounting
15.	Seat, H.P.R.V. Spring	68.	Piston, Pump	122.	Flange, Suction
*16.	Plunger, H.P.R.V.	69.	Tubing, Gear Pump	123.	Screw, Set
17.	Liner, Case	70.	Cover, Rotor	124.	Cup, Thrust
18.	Dowel, Case Liner	71.	Screw, Rotor Cover	125.	Sleeve, Control
19.	Dowel, Slide Block Liner	72.	Rotor	126.	Plate, Thrust
20.	Liner, Slide Block	*73.	Cylinder, Pump	127.	Ring, Retainer
21.	Case, Pump	*74.	Bushing, Cylinder	127A.	Screw, Retainer Ring
22.	Cage, Check Valve	75.	Shim, B.P.R.V.	128.	Shim, Slide Block Spacer Ring
23.	Spring, Check Valve	76.	Plunger, G.P.R.V.	129.	Ring, Slide Block Spacer
24.	Gasket, Check Valve	77.	Plunger, G.P.R.V. Dashpot	130.	Spring, Check Valve
25.	Disc, Check Valve	78.	Shim, G.P.R.V.	131.	Gasket, Suction Valve
26.	Seat, Check Valve	79.	Cap, G.P.R.V.	132.	Disc, Check Valve
27.	Body, Suction Valve	80.	Spacer, G.P.R.V.	133.	Plug, Pipe
28.	Gasket, Flange	81.	Spring, G.P.R.V.	134.	Spring, Thrust Bearing
29.	Disc, Check Valve	82.	Gasket, G.P.R.V. Cap	135.	Filter, Oil
30.	Gasket, H.P.R.V. Cap	83.	Eyebolt	136.	Valve, Flow Control
31.	Cap, H.P.R.V.	84.	Nameplate	137.	Gage, Filter
32.	Screw, H.P.R.V. Adjusting	85.	Slide Block	138.	Pin, Locking
33.	Pin, Guide	86.	Bearing, Front Rotor	139.	Packing, O' Ring (See list)
34.	Bearing, Thrust	87.	Gasket, G.P. Housing	140.	Packing, O' Ring (See list)
35.	Piston, Large Control	88.	Shim, Front Rotor Bearing	141.	Packing, O' Ring (See list)
36.	Ring, Large Control Piston	89.	Gasket, G.P. Cover Screw	142.	Screw, Sock. Hd. Cap
37.	Gasket, Control Housing	90.	Screw, G.P. Cover	143.	Plug Pipe
38.	Housing, Control	91.	Gear, G.P. Driver	144.	Plug, Pipe
38A.	Screw, Sock. Hd. Cap	92.	Plate, Rotation Direction	145.	Screw, Sock. Hd. Cap
39.	Plunger, Control	93.	Key, G.P. Drive	146.	Screw, Sock. Hd. Cap
40.	Flange, Angle	94.	Shim, Front Shaft Bearing	147.	Plug, Pipe
41.	Gasket, Flange	95.	Gasket, Seal Housing	148.	Screw, Lever Retaining
42.	Flange, Straight	96.	Washer, Lock	149.	Plug, Pipe
43.	Seal, Plunger Oil	97.	Nut, Lock	150.	Plug, Pipe
44.	Shim, Gland	98.	Shaft, Drive	151.	Screw, Sock. Hd. Cap
45.	Gland, Oil Seal	99.	Seal, Shaft	152.	Plug, Pipe
46.	Lever, Control	100.	Housing, Shaft Seal	153.	Ring, Small Control Piston
47.	Tube, L.H. Control	101.	Bearing, Front Shaft	154.	Seat, Check Valve
48.	Tube, R.H. Control	102.	Shaft, G.P. Stub	155.	Plug, Pipe
49.	Flange, Pipe	103.	Bearing, G.P. Roller	156.	Screw, Sock. Hd. Cap
50.	Gasket, Flange	104.	Gear, G.P. Driven	157.	Shaft, Drive
51.	Cover, Pintle	105.	Housing, Gear Pump	158.	Housing, Scavenger G.P.

## O' RING SIZES

## DHH-35

139. Packing, O'Ring (1/8x 1-1/4x 1-1/2)  
 140. Packing, O'Ring (1/8x 1-3/8x 1-5/8)  
 141. Packing, O'Ring (1/8x 1-7/16x 1-11/16)

## DHH-60

140. Packing, O'Ring (1/8x 1-1/2x 1-3/4)  
 141. Packing, O'Ring (1/8x 1-5/8x 1-7/8)

Note: When ordering O'Rings for other than hydraulic oil service, specify name of fluid. Specify O'Rings of 70 durometer hardness.

\* Parts No. 16 & 117 and No. 73 and No. 74 are furnished only as assemblies.

DS-947450

When ordering parts be sure to include serial number of pump.