

TYPE "DP" PUMP

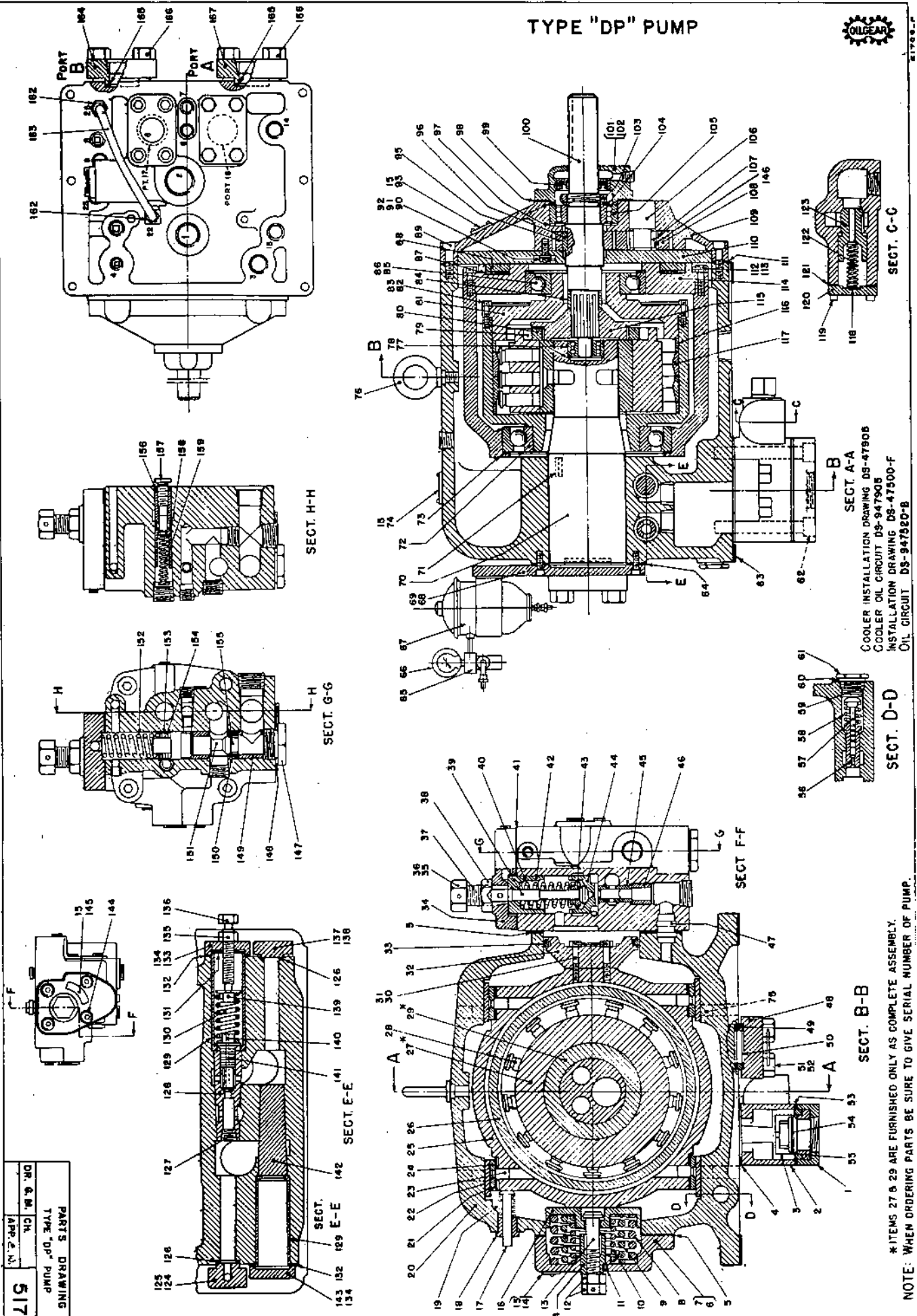

DR. & M. CH.
PARTS DRAWING
TYPE "DP" PUMP
51722-C
APP. 2-1-51

REISSUED JAN 8, 1951

THE OILGEAR COMPANY
MILWAUKEE 4, WISCONSIN, U.S.A.

DS-947500-C

COOLER INSTALLATION DRAWING DS-4780B
COOLER OIL CIRCUIT DS-94790B
INSTALLATION DRAWING DS-47500-F
OIL CIRCUIT DS-94792-B

* ITEMS 27 & 29 ARE FURNISHED ONLY AS COMPLETE ASSEMBLY.
NOTE: WHEN ORDERING PARTS BE SURE TO GIVE SERIAL NUMBER OF PUMP.

PARTS LIST
OILGEAR "DP" PUMPS

NO.	PARTS	NO.	PARTS	NO.	PARTS
1.	Flange, Suction	57.	Plunger, G.P.R.V. Dashpot	113.	Wire, Lock
2.	Body, Suction Valve	58.	Spring, G.P.R.V.	114.	Cover, Slide Block
3.	Cage, Check Valve	59.	Shim, G.P.R.V.	115.	Flange, Coupling
4.	Gasket, Suction Valve Body	60.	Gasket, G.P.R.V. Cap	116.	Ring, Spacer
5.	Gasket, Control Cyl. Cover	61.	Cap, G.P.R.V.	117.	Ring, Thrust
6.	Cover, Control Cylinder	62.	Screw, Suction Valve	118.	Shim, B.P.R.V.
7.	Screw, Cover	63.	Gasket, Reservoir	119.	Screw, Cap
8.	Spring, Large Control	64.	Gasket, Pintle Cover	120.	Cap, B.P.R.V.
9.	Spring, Intermed. Control	65.	Valve, Flow Control	121.	Gasket, B.P.R.V. Cap
10.	Spring, Small Control	66.	Gage, Change Indicator	122.	Spring, B.P.R.V.
11.	Screw, Bushing Lock	67.	Filter, Oil	123.	Plunger, B.P.R.V.
12.	Nut, Stroke Adj. Stop	68.	Cover, Pintle	124.	Flange, Auxiliary
13.	Screw, Stroke Adjusting	69.	Screw, Cover	125.	Screw, Flange
14.	Nameplate, Control	70.	Pintle	126.	Gasket, Flange
15.	Screw, Drive	71.	Key, Pintle	127.	Plug, Pipe
16.	Cage, Control Spring	72.	Bearing, Rear Rotor	128.	Bushing, H.P.R.V.
17.	Stem, Indicator	73.	Shim, Rear Rotor Brg.	129.	Retainer, H.P.R.V. Bushing
18.	Bushing, Indicator	74.	Nameplate	130.	Spring, H.P.R.V.
19.	Spring, Indicator	75.		131.	Shim, Retainer
20.	Case, Pump	76.	Eyebolt	132.	Gasket, Cap
21.	Shim, Liner	77.	Bearing, Rear Shaft	133.	Cap, H.P.R.V.
22.	Liner, Case	78.	Shim, Rear Shaft Brg.	134.	Screw, Cap
23.	Dowel, Slide Block Liner	79.	Roller, Coupling	135.	Nut, Lock
24.	Liner, Slide Block	80.	Ring, Coupling	136.	Screw, H.P.R.V. Adjusting
25.	Block, Slide	81.	Cover, Rotor	137.	Flange, Auxiliary
26.	Rotor	82.	Screw, Rotor Cover	138.	Screw, Flange
27.	Cylinder*	83.	Wire, Lock	139.	Seat, Spring
28.	Piston	84.	Spacer, Coupling	140.	Seat, Spring
29.	Bushing, Cylinder*	85.	Bearing, Front Rotor	141.	Plunger, H.P.R.V.
30.	Screw, Piston	86.	Shim, Front Rotor Brg.	142.	Plug, Dummy
31.	Wire, Lock	87.	Shim, Spacer Ring	143.	Cap, Blind
32.	Piston, Control	88.	Ring, Slide Block Spacer	144.	Screw, Spring Cap
33.	Ring, Control Piston	89.	Screw, Gear Pump Housing	145.	Plate, Control Name
34.	Cover, Spring	90.	Screw, Gear Pump Cover	146.	Spacer, Bearing
35.	Nut, Limit	91.	Gasket, G.P. Cover Screw	147.	Cap, Pilot R.V.
36.	Pin, Adjusting Screw	92.	Wire, Lock	148.	Gasket, Cap
37.	Screw, Pilot R.V. Adj.	93.	Plate, Rotation Direction	149.	Spacer, Bushing
38.	Nut, Lock	94.	Bushing, Control Screw	150.	Bushing, Pilot R.V.
39.	Guide, Pilot R.V. Spring	95.	Gear, G.P. Driver	151.	Plunger, Pilot R.V.
40.	Spring, Pilot R.V.	96.	Key, G.P. Driver	152.	Spring, Pilot R.V.
41.	Gasket, Spring Cover	97.	Shim, Front Shaft Brg.	153.	Shim, Pilot R.V.
42.	Piston, Pilot R.V. Guide	98.	Gasket, Oil Seal Housing	154.	Shim, Pilot R.V.
43.	Seat, Spring	99.	Seal, Oil	155.	Seat, Pilot R.V.
44.	Plunger, Pilot R.V.	100.	Shaft, Drive	156.	Nut, Neutral Stop Lock
45.	Bushing, Pilot R.V.	101.	Housing, Oil Seal	157.	Screw, Neutral Stop
46.	Spacer, Bushing	102.	Screw, Housing	158.	Plunger, Neutral Stop
47.	Bushing, H.P. Inlet	103.	Nut, Bearing Lock	159.	Spring, Neutral Stop
48.	Flange, Blind	104.	Washer, Bearing Lock	160.	
49.	Spacer, Flange	105.	Bearing, Front Shaft	161.	
50.	Gasket, Spacer	106.	Shaft, G.P. Stub	162.	Fitting, Weatherhead
51.	Screw, Flange	107.	Bearing, Driven Gear	163.	Tube, Back Pressure
52.	Wire, Lock	108.	Gear, G.P. Driven	164.	Flange, Port B. Connection
53.	Gasket, Suction Flange	109.	Housing, Gear Pump	165.	Gasket, Flange
54.	Disc Check Valve	110.	Cover, Gear Pump	166.	Screw, Flange
55.	Seat, Check Valve	111.	Gasket, G.P. Housing	167.	Flange, Port A. Connection
56.	Plunger, G.P.R.V.	112.	Screw, Slide Block Cover		

*Parts 27 and 29 furnished only as a complete assembly.

NOTE: When ordering parts be sure to give the serial number of pump.