

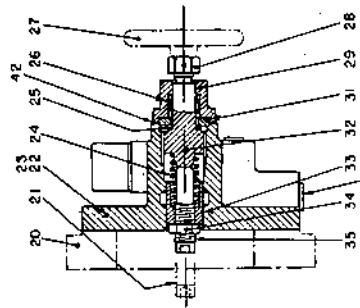

TYPE "DP" PUMP WITH REMOTE CONTROL

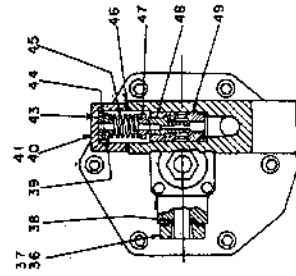

CONTROL FOR 60 & 100 H.P. PUMPS

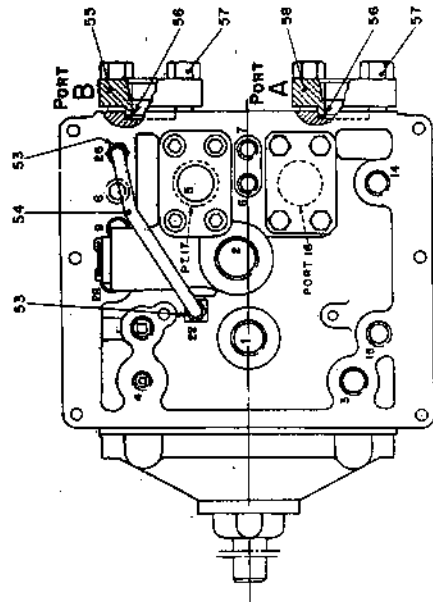
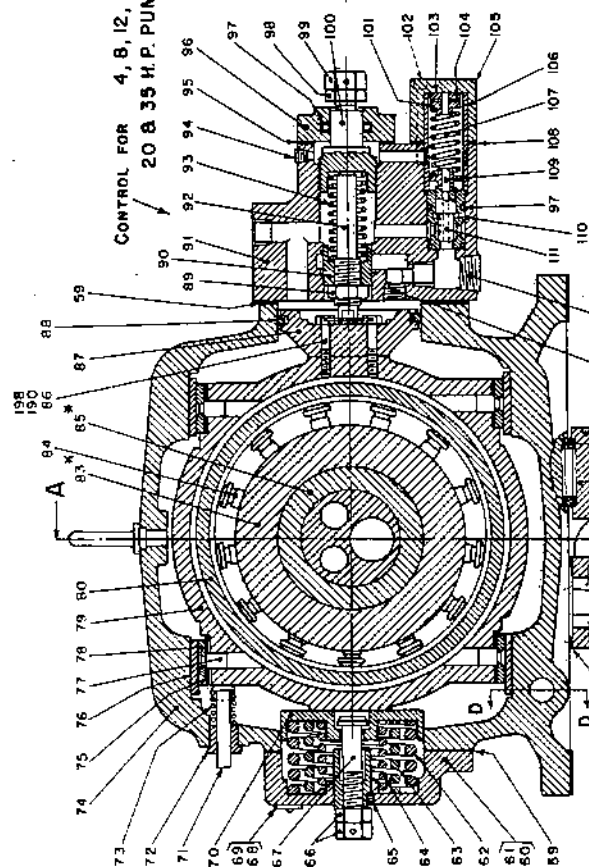
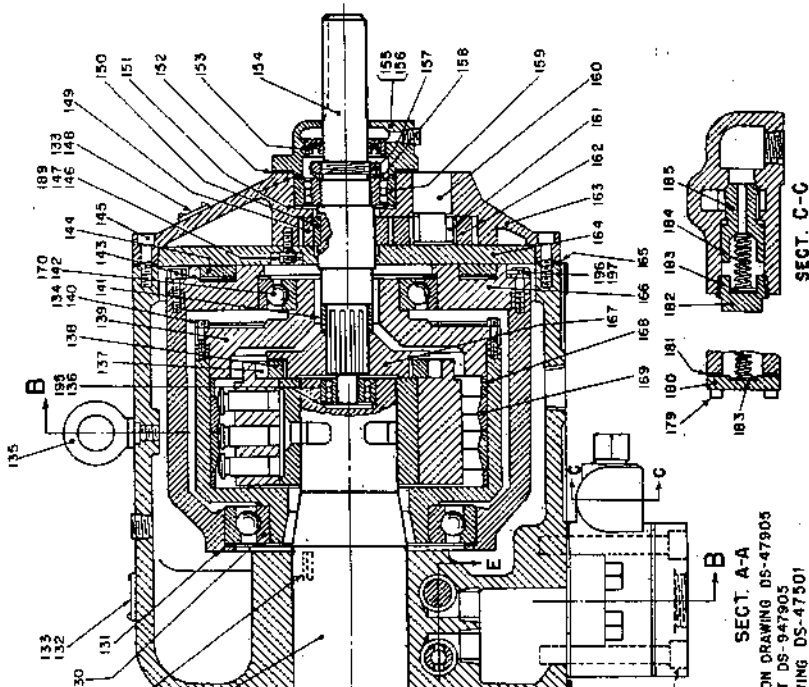

CONTROL FOR 20 & 35 H.P. PUMPS

57228A
APPROVED
CHK
DR. & M.
PARTS DRAWING
TYPE "DP" PUMP WITH
REMOTE CONTROL

ISSUED JAN. 6 1951

THE OILGEAR COMPANY MILWAUKEE 4, WISCONSIN, U.S.A.

DS-94750I-A

* ITEMS 85 & 86 ARE FURNISHED ONLY AS COMPLETE ASSEMBLY. NOTE: WHEN ORDERING PARTS BE SURE TO GIVE SERIAL NUMBER OF PUMP.

COOLER INSTALLATION DRAWING DS-47903
COOLER OIL CIRCUIT DS-947905
INSTALLATION DRAWING DS-47501
OIL CIRCUIT: SINGLE DS-94752H, DUAL DS-94752Z

SECT. B-B

SECT. A-A

SECT. D-D

SECT. C-C

PARTS LIST
OILGEAR "DP" PUMPS WITH REMOTE CONTROL

NO.	PARTS	NO.	PARTS	NO.	PARTS
1.	Flange, Auxiliary	67.	Screw, Stroke Limit	133.	Screw, Drive
2.	Screw, Flange	68.	Nameplate, Control	134.	Wire, Locking
3.	Gasket, Flange	69.	Screw, Drive	135.	Eyebolt
4.	Plug, Pipe	70.	Guide, Control Spring	136.	Bearing, Rear Shaft
5.	Bushing, H.P.R.V.	71.	Stem, Indicator	137.	Roller, Coupling
6.	Retainer, H.P.R.V. Bushing	72.	Bushing, Indicator	138.	Ring, Coupling
7.	Spring, H.P.R.V.	73.	Spring, Indicator	139.	Cover, Rotor
8.	Shim, H.P.R.V.	74.	Case, Pump	140.	Screw, Rotor Cover
9.	Gasket, H.P.R.V. Cap	75.	Shim, Slide Block Liner	141.	Spacer, Coupling
10.	Cap, H.P.R.V.	76.	Liner, Case	142.	Bearing, Front Rotor
11.	Screw, H.P.R.V. Cap	77.	Dowel, Slide Block Liner	143.	Shim, Slide Block
12.	Nut, Lock	78.	Liner, Slide Block	144.	Ring, Slide Block Spacer
13.	Screw, H.P.R.V. Adjusting	79.	Block, Slide	145.	Screw, Gear Pump Housing
14.	Plug, Pipe	80.	Rotor	146.	Screw, Gear Pump Cover
15.	Flange, Auxiliary	81.		147.	Gasket, G.P. Cover Screw
16.	Seat, H.P.R.V. Spring	82.		148.	Plate, Rotation Direction
17.	Seat, H.P.R.V. Spring	83.	Cylinder*	149.	Gear, G.P. Driver
18.	Plunger, H.P.R.V.	84.	Piston	150.	Key, Gear Pump
19.	Plug, Dummy	85.	Bushing, Cylinder*	151.	Shim, Front Shaft Bearing
20.	Adapter, Control	86.	Screw, Piston, Control	152.	Gasket, Seal Housing
21.	Screw, Adjusting	87.	Piston, Control	153.	Seal, Shaft, Oil
22.	Housing, Control	88.	Ring, Piston	154.	Shaft, Drive
23.	Screw, Housing	89.	Nut, Lock	155.	Housing, Shaft Seal
24.	Spring, Neutral Stop	90.	Plunger, Neutral Stop	156.	Screw, Housing
25.	Shim, Full Stroke Stop	91.	Housing, Control	157.	Nut, Lock
26.	Packing, Adjusting Screw	92.	Screw, Neutral Stop Adj.	158.	Washer, Lock
27.	Handwheel, Control	93.	Spring, Neutral Stop	159.	Bearing, Front Shaft
28.	Nut, Stroke Adj. Screw	94.	Plug, Pipe	160.	Shaft, G.P. Stub
29.	Gland, Adjusting Screw	95.	Gasket, Gland	161.	Bearing, G. P. Roller
30.	Screw, Gland	96.	Gland, Adjusting Screw	162.	Gear, G.P. Driven
31.	Ring, Centralizing	97.	Packing, O'Ring	163.	Housing, Gear Pump
32.	Screw, Stroke Adjusting	98.	Nut, Lock	164.	Cover, Gear Pump
33.	Plunger, Neutral Stop	99.	Nut, Adjusting Screw	165.	Gasket, G.P. Housing
34.	Nut, Lock	100.	Screw, Stroke Adjusting	166.	Cover, Slide Block
35.	Screw, Neutral Stop Adj.	101.	Seat, Outer Spring	167.	Flange, Coupling
36.	Flange, Pipe	102.	Screw, Cap	168.	Spacer, Thrust Ring
37.	Screw, Flange	103.	Shim, Control R.V.	169.	Ring, Thrust
38.	Gasket, Flange	104.	Shim, Control R.V.	170.	Shim, Front Rotor Brg.
39.	Seat, Control R.V. Spring	105.	Cover, Control R.V.	171.	Screw, Valve Mounting
40.	Cap, Control R.V.	106.	Sleeve, Retaining	172.	Gasket, Reservoir
41.	Screw, Cap	107.	Spring, Control R.V.	173.	Plunger, G.P.R.V.
42.	Gasket, Gland	108.	Gasket, Cover	174.	Plunger, G.P.R.V. Dashpot
43.	Shim, Control R.V.	109.	Seat, Inner Spring	175.	Spring, G.P.R.V.
44.	Shim, Control R.V.	110.	Bushing, Control R.V.	176.	Shim, G.P.R.V.
45.	Spring, Control R.V.	111.	Plunger, Control R.V.	177.	Gasket, G.P.R.V. Cap
46.	Gasket, Cap	112.	Plug, Pipe	178.	Cap, G.P.R.V.
47.	Seat, Control R.V. Spring	113.	Plug, Pipe	179.	Screw, B.P.R.V. Cap
48.	Plunger, Control R.V.	114.	Flange, Blind	180.	Cap, B.P.R.V.
49.	Bushing, Control R.V.	115.	Spacer, Gasket	181.	Gasket, B.P.R.V. Cap
50.	Plug, Pipe	116.	Gasket, Suction Flange	182.	Plug, B.P.R.V.
51.		117.	Screw, Flange	183.	Shim, B.P.R.V.
52.		118.	Gasket, Suction Flange	184.	Spring, B.P.R.V.
53.	Fitting, Weatherhead	119.	Disc, Check Valve	185.	Plunger, B.P.R.V.
54.	Fitting, Copper	120.	Seat, Check Valve	186.	Valve, Flow Control
55.	Flange, Connection	121.	Flange, Suction	187.	Gage, Change Indicator
56.	Gasket, Connection Flange	122.	Body, Suction Valve	188.	Filter, Oil
57.	Bolt Flange	123.	Cage, Check Valve	189.	Wire, Locking
58.	Flange, Connection	124.	Pin, Taper	190.	Gasket, Piston Screw
59.	Gasket, Connection Flange	125.	Handwheel	191.	Wire, Locking
60.	Cover, Control Spring	126.	Cover, Pintle	192.	Cap, Relief Valve Blind
61.	Screw, Cover	127.	Screw, Cover	193.	Screw, Flange
62.	Spring, Large Control	128.	Pintle	194.	Gasket, Pintle Cover
63.	Spring, Intermed. Control	129.	Key, Pintle	195.	Shim, Rear Shaft Brg.
64.	Spring, Small Control	130.	Bearing, Rear Rotor	196.	Screw, Slide Block Cover
65.	Screw, Set	131.	Shim, Rear Rotor Bearing	197.	Wire, Locking
66.	Nut, Control Screw	132.	Nameplate	198.	Wire, Locking

*Parts 83 and 85 furnished only as a complete assembly.

NOTE: When ordering parts be sure to give serial number of pump.