

# TYPE "DR-2011" PUMP

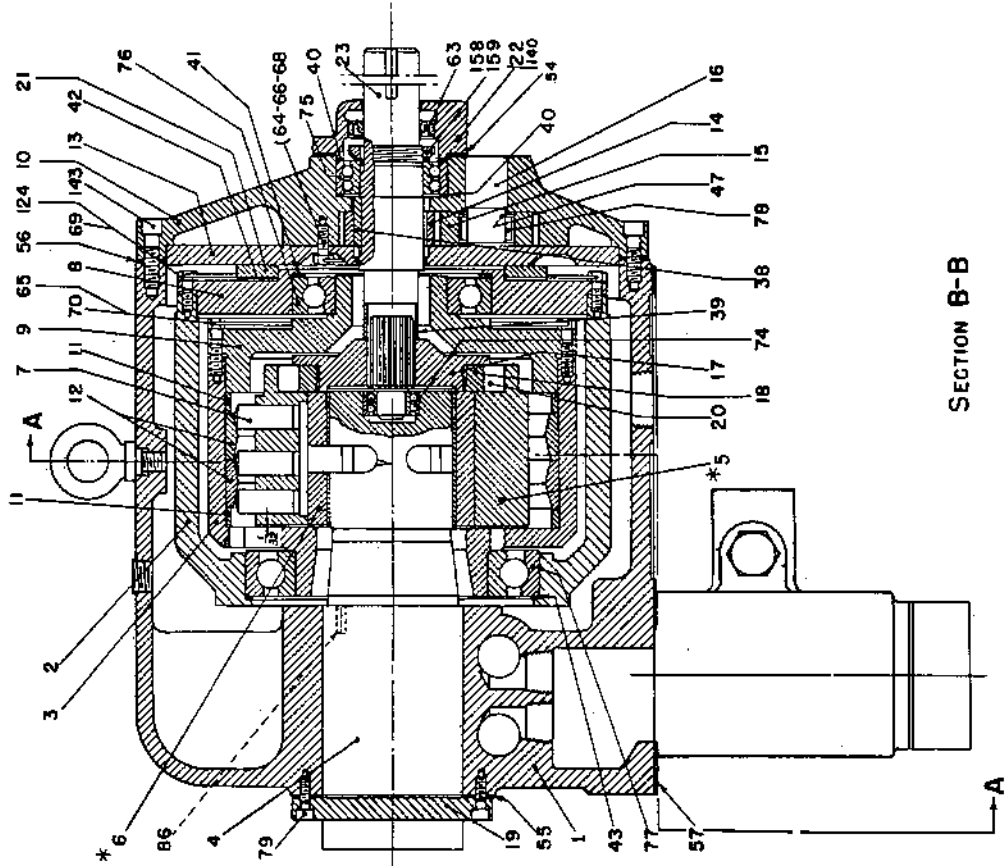

58736



SECTION B-B

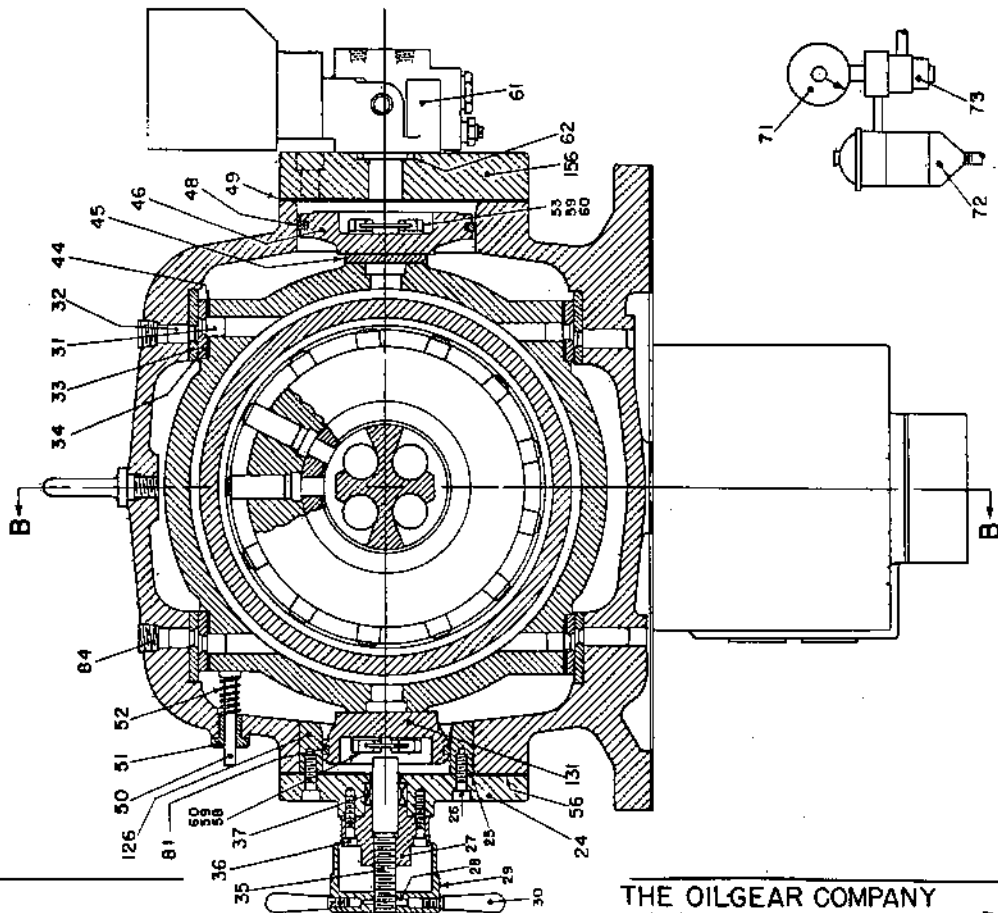

SECTION A-A

\* ITEMS 5 & 6 ARE FURNISHED ONLY AS COMPLETE ASSEMBLIES

PARTS DRAWING	
SPECIAL DR-2011 PUMP	
DR. G. M.	CH. G. M.
APP. 2	NO. 58
58736	

2 SH. NO. 58  
1 CH. NO. 58

ISSUED MAY 15, 1954

THE OILGEAR COMPANY  
MILWAUKEE 4, WISCONSIN, U.S.A.

DS-947605

## PARTS LIST

OILGEAR TYPE "DR-2011" PUMP

SH.NO.1  
NO.SH.2

NO.	PARTS	NO.	PARTS
1.	Case, Pump	46.	Piston, Control
2.	Slide Block	47.	Retainer, G.P. Bearing
3.	Rotor, Pump	48.	Ring, Piston
4.	Pintle, Pump	49.	Gasket, Head, Control
5.	Cylinder, Pump*	50.	Stem, Indicator
6.	Bushing, Cylinder*	51.	Bushing, Indicator
7.	Piston, Pump	52.	Spring, Indicator
8.	Cover, Slide Block	53.	Screw, Piston, Control
9.	Cover, Rotor	54.	Gasket, Seal Housing
10.	Housing, Gear Pump	55.	Gasket, Cover, Pintle
11.	Ring, Spacer	56.	Gasket, Housing, Control
12.	Ring, Thrust	57.	Gasket, Oil Reservoir
13.	Cover, Gear Pump	58.	Screw, Piston, Control
14.	Gear, G.P. Driver	59.	Gasket, Screw, Piston
15.	Gear, G.P. Driven	60.	Wire, Lock
16.	Shaft, G.P. Stub	61.	Valve, Pilot, Electric(DS-980)
17.	Flange, Coupling	62.	Gasket, "O" Ring
18.	Ring, Coupling	63.	Seal, Shaft
19.	Cover, Pintle	64.	Screw, Cover, G.P.
20.	Roller, Coupling	65.	Screw, Cover, Rotor
21.	Ring, Slide Block Spacer	66.	Gasket, Cover Screw, G.P.
22.	Housing, Shaft Seal	68.	Wire, Lock
23.	Shaft, Drive	69.	Wire, Lock
24.	Head, Control	70.	Wire, Lock
25.	Gasket, Adapter	71.	Gage, Filter
26.	Screw, Control Adapter	72.	Filter, Oil
27.	Gland, Control	73.	Valve, Flow Control
28.	Pin, Taper	74.	Bearing, Rear Shaft
29.	Knob, Control	75.	Bearing, Front Shaft
30.	Handle, Adjusting, Control	76.	Bearing, Front Rotor
31.	Dowel, Liner, Slide Block	77.	Bearing, Rear Rotor
32.	Dowel, Liner, Case	78.	Bearing, G.P. Roller
33.	Liner, Case	79.	Screw, Pintle Cover
34.	Liner, Slide Block	81.	Ring, Piston, Control
35.	Screw, Adjusting, Control	84.	Plug, Pipe
36.	Screw, Gland, Control	86.	Key, Pintle
37.	Packing, Control	124.	Screw, Cover, Slide Block
38.	Key, G.P. Drive	126.	Adapter, Piston, Control
39.	Spacer, Coupling	131.	Piston, Control
40.	Shim, Front Shaft Bearing	140.	Screw, Cap, Sock. Hd.
41.	Shim, Front Rotor Bearing	143.	Screw, Housing, G.P.
42.	Shim, Slide Block Spacer	156.	Head, Control
43.	Shim, Rear Bearing, Rotor	158.	Washer, Lock
44.	Shim, Liner, Slide Block	159.	Nut, Lock
45.	Spacer, Piston, Control		

\*Parts 5 and 6 are furnished only as a complete assembly.

NOTE: When ordering parts be sure to give serial number of pump.