

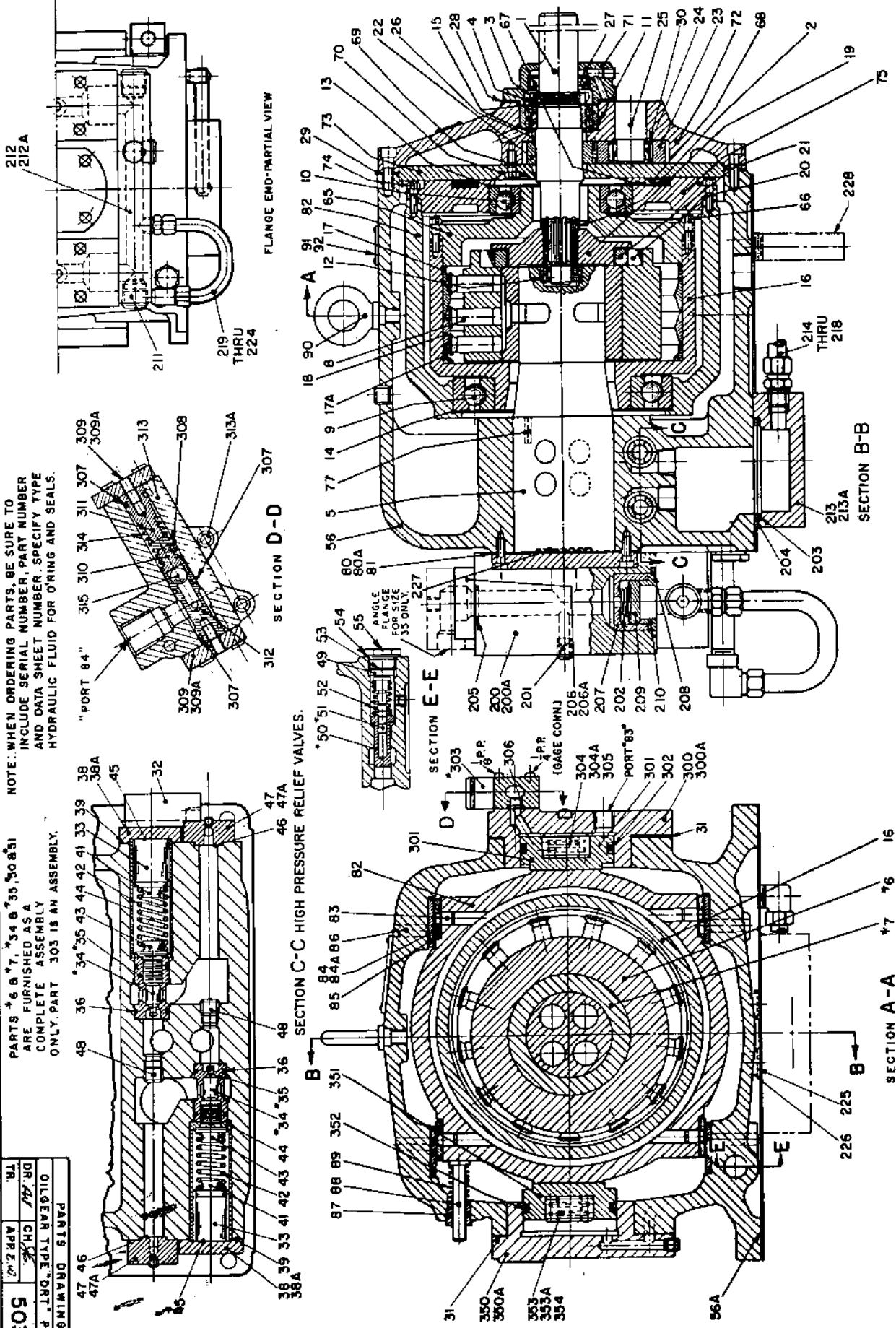

# OILGEAR SPECIAL TWO-WAY VARIABLE DELIVERY PUMPS

"DRT"



TR.	DATE	BY	CHKD.	APPROV.
OILGEAR DRAWING				
503146				
OILGEAR TYPE PUMPS				
SAUNDERS LEO. CO.				

ISSUED MAY, 1961

THE OILGEAR COMPANY  
MILWAUKEE 4, WISCONSIN, U.S.A.

DS-947614

LITCO, INC. U.S.A. 503146  
1962

PARTS LIST  
OILGEAR SPECIAL "DR" VARIABLE DISPLACEMENT PUMP

PART NO.	DESCRIPTION	PART NO.	DESCRIPTION	PART NO.	DESCRIPTION
1.	Shaft, Drive	*50.	Plunger, Dash-pot	211.	Plug, Pipe
2.	Spacer, Coupling	*51.	Plunger, G. P. R. V.	212.	Manifold, Pressure
3.	Nut, Lock	52.	Spring, G. P. R. V.	212A.	Screw, Sock. Hd. Cap
4.	Washer, Lock	53.	Shims, G. P. R. V.	213.	Flange, Suction
5.	Pintle	54.	Gasket, G. P. R. V.	213A.	Screw, Sock. Hd. Cap
*6.	Cylinder	55.	Cap, G. P. R. V.	214.	Nut, Ermeto Coupling
*7.	Bushing, Cylinder	56.	Case, Pump	215.	Sleeve, Ermeto Coupling
8.	Piston, Radial	56A.	Gasket, Pump Mounting	216.	Connector, Ermeto
9.	Bearing, Rear Rotor			217.	Elbow, Ermeto
10.	Bearing, Frt. Rotor	65.	Head, Rotor	218.	Tubing, Steel
11.	Bearing, Frt. Dr. Shaft	66.	Screw, Rotor Head	219.	Nipple, Pipe
12.	Bearing, Rear Dr. Shaft	67.	Shims, Slideblock Cover	220.	Elbow, Ermeto
13.	Shim, Frt. Rotor Brg.	68.	Ring, Slideblock Spacer	221.	Nut, Ermeto
14.	Shim, Rear Rotor Brg.	69.	Screw, Gear Pump Cover	222.	Sleeve, Ermeto
15.	Shim, Frt. Dr. Shaft Brg.	70.	Gasket, G. P. Cover Screw	223.	Tubing, Steel
16.	Rotor	71.	Housing, Oil Seal	224.	Connector, Ermeto
17.	Ring, Spacer	72.	Housing, Gear Pump	225.	Retainer
17A.	Ring, Spacer	73.	Cover, Gear Pump	225.	Seal, O'Ring
18.	Ring, Thrust	74.	Screw, Slideblock Cover	227.	Seal, O'Ring
19.	Flange, Coupling	75.	Head, Slideblock	228.	Pipe, G. P. Suction
20.	Roller, Coupling	77.	Key, Pintle		
21.	Ring, Coupling	80.	Cover, Pintle End	300.	Head, Control
22.	Gear, Driving	80A.	Screw, Sock. Hd. Cap	300A.	Screw, Sock. Hd. Cap
23.	Gear, Driven	81.	Gasket, Pintle Cover	301.	Piston, Control
24.	Bearing, Roller	82.	Slideblock	302.	Seal, Block Vee
25.	Shaft, Stub	83.	Pin, Dowel	303.	Assembly, Relief Valve
26.	Key, Drive Shaft	84.	Liner, Slideblock	304.	Spacer, Adjustable
27.	Seal, Oil	84A.	Shims, Liner	304A.	Screw, Sock. Hd. Cap
28.	Gasket, Front Cover	85.	Liner, Case	305.	Screw, Adj.
29.	Gasket, Gear Pump Hsg.	86.	Pin, Dowel	306.	Seal, O'Ring
30.	Spacer, Bearing	87.	Bushing, Indicator	307.	Seal, O'Ring
31.	Gasket, Control Mounting	88.	Stem, Indicator	308.	Seal, O'Ring
32.	Flange, Port 11	89.	Spring, Indicator	309.	Cap, Relief Valve
33.	Spacer, H. P. R. V.	90.	Eyebolt	309A.	Screw, Sock. Hd. Cap
*34.	Plunger, H. P. R. V.	91.	Nameplate	310.	Cage, Spring
*35.	Bushing, H. P. R. V.	92.	Screw, Drive	311.	Guide, Spring
36.	Seal, O'Ring			312.	Seat, Relief Valve
38.	Cap, H. P. R. V.	200.	Flange	313.	Body, Valve
38A.	Screw, Sock. Hd. Cap	200A.	Screw, Sock. Hd. Cap	313A.	Screw, Sock. Hd. Cap
39.	Gasket, H. P. R. V.	201.	Plug, Pipe	314.	Spring, Relief Valve
41.	Guide, Spring	202.	Spring, Check Valve	315.	Ball, Steel
42.	Spring, H. P. R. V.	203.	Seal, O'Ring		
43.	Guide, Spring	204.	Retainer, Seal		
44.	Retainer, Bushing	205.	Seal, O'Ring	350.	Head, Control Cylinder
45.	Shim, Retainer	206.	Flange, Port	350A.	Screw, Sock. Hd. Cap
46.	Gasket, Aux. Port	206A.	Screw, Sock. Hd. Cap	351.	Piston, Control
47.	Flange, Aux. Port	207.	Cage, Check Valve	352.	Ring, Piston
47A.	Screw, Sock. Hd. Cap	208.	Seal, O'Ring	353.	Spacer, Adj.
48.	Plug, Pipe	209.	Disc, Check Valve	353A.	Screw, Sock. Hd. Cap
49.	Spacer, G. P. R. V.	210.	Seat, Disc	354.	Screw, Adj.

O'RING SIZES

Part No.	Cross Section	x	I. D.	x	O. D.	Duro ± 5	Part No.	Cross Section	x	I. D.	x	O. D.	Duro ± 5
36.	1/8	x	1-1/2	x	1-3/4	90	227.	1/8	x	2-1/2	x	2-3/4	90
203.	3/16	x	3-1/2	x	3-7/8	70	306.	3/32	x	9/16	x	3/4	70
205.	1/8	x	1-1/2	x	1-3/4	90	307.	3/32	x	7/16	x	5/8	70
208.	3/16	x	3	x	3-3/8	90	308.	1/16	x	3/8	x	1/2	70
226.	3/16	x	2-1/2	x	2-7/8	90							

\* Note: Part numbers 6 & 7, 34 & 35, 50 & 51, are furnished only as an assembly.

When ordering repair parts, be sure to include pump serial number, part number and data sheet number. Specify type of fluid for seals.

THE OILGEAR COMPANY  
Milwaukee 4 Wisconsin