

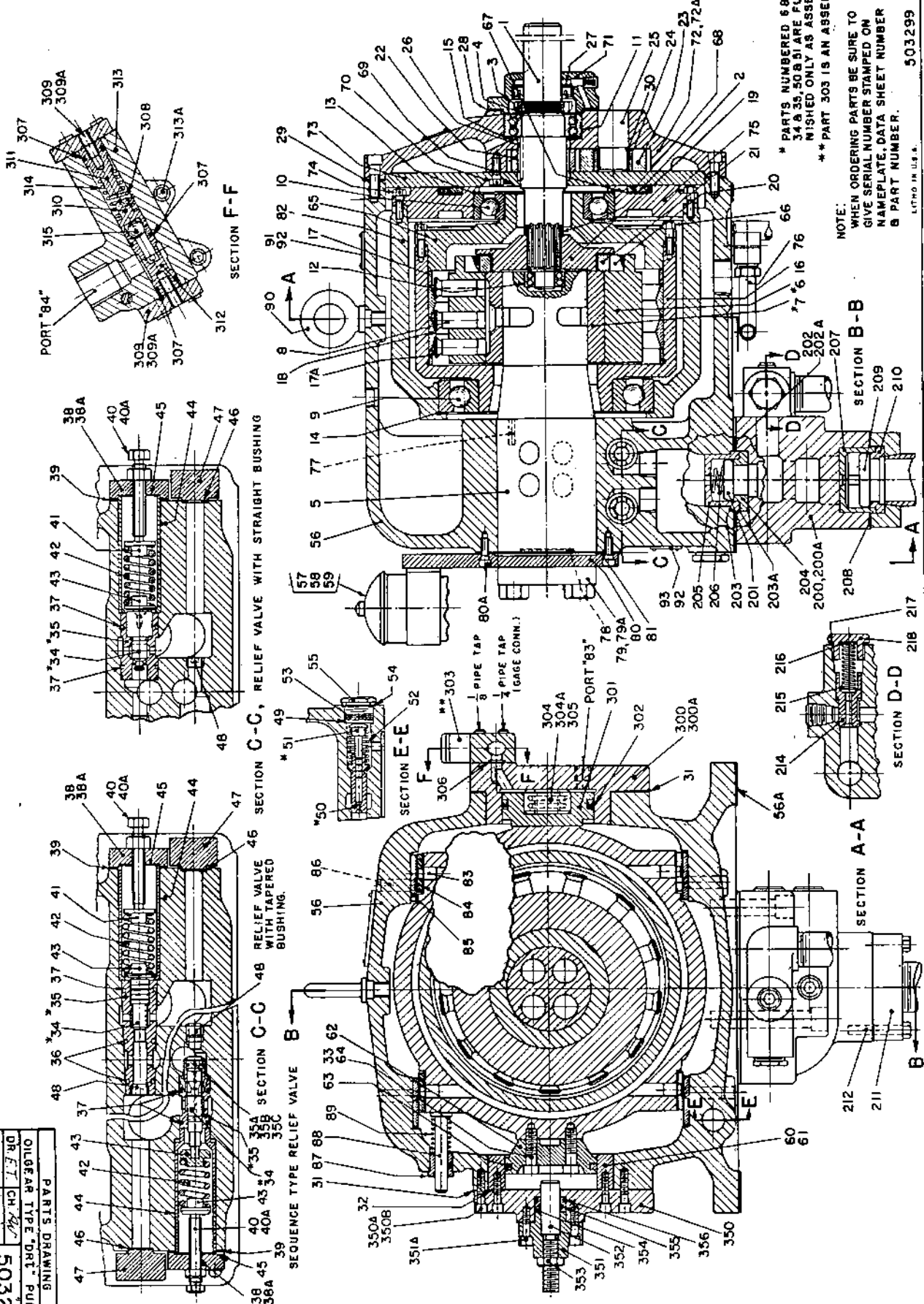

# OILGEAR SPECIAL TYPE "DR" PUMPS

SIZES B THRU 60

662205	503222
DR	TR
CH	APP
APP	APP
PARTS DRAWING	
OILGEAR "DR" TYPE PUMP	



\* PARTS NUMBERED 69, 74 & 85, 80B ARE PURCHASED ONLY AS ASSEMBLIES. \*\* PART 303 IS AN ASSEMBLY.

NOTE: WHEN ORDERING PARTS BE SURE TO GIVE SERIAL NUMBER STAMPED ON NAMEPLATE, DATA SHEET NUMBER & PART NUMBER.

LITHO IN U.S.A. 503299

ISSUED: SEPT. 1961

THE OILGEAR COMPANY  
MILWAUKEE 4, WISCONSIN U.S.A.

DS-947615

PARTS LIST  
OILGEAR TYPE "DRT" PUMPS

Part No.	Description	Part No.	Description	Part No.	Description
1.	Shaft, Drive	48.	Plug Pipe	200.	Body, Suction Valve
2.	Spacer, Coupling	49.	Spacer G. P. R. V.	200A.	Screw, Sock. Hd. Cap
3.	Nut, Lock	* 50.	Plunger, Dashpot	201.	Disc., Check Valve
4.	Washer, Lock	* 51.	Plunger, G. P. R. V.	202.	Gasket, H. P. Exhaust
5.	Pintle	52.	Spring, G. P. R. V.	202A.	Retainer, H. P. Exhaust
* 6.	Cylinder	53.	Shims, G. P. R. V.	203.	Gasket, Upper Cage
* 7.	Bushing, CyHinder	54.	Gasket, G. P. R. V.	203A.	Retainer, Gasket
8.	Piston, Radial	55.	Cap, G. P. R. V.	204.	Seat, Check Valve
9.	Bearing, Rear Rotor	56.	Case, Pump	205.	Cage, Check Valve
10.	Bearing, Front Rotor	56A.	Gasket, Pump Mtg.	206.	Spring, Check Valve
11.	Bearing, Frt. Dr. Shaft.	57.	Filter, Oil	207.	Cage, Suction Flange
12.	Bearing, Rear Dr. Shaft.	58.	Valve, Flow Control	208.	Gasket, Suction Flange
13.	Shim, Front Rotor Brg.	59.	Gage, Filter	209.	Disc., Suct. Check Valve
14.	Shim, Rear Rotor Brg.	60.	Adapter, Control Cyl.	210.	Seat, Suct. Check Valve
15.	Shim, Front Drive Shaft. Brg	61.	Screw, Control Piston Adapt.	211.	Flange, Suction
16.	Rotor	62.	Piston, Control	212.	Screw, Suct. Flange
17.	Ring, Spacer	63.	Ring, Piston	214.	Plunger, B. P. R. V.
17A.	Ring, Spacer	64.	Screw, Control Piston	215.	Spring, B. P. R. V.
18.	Ring, Thrust	65.	Head, Rotor	216.	Shim, B. P. R. V.
19.	Flange, Coupling	66.	Screw, Rotor Head	217.	Gasket, B. P. R. V.
20.	Roller, Coupling	67.	Shims, Slideblock Cover	218.	Cap, B. P. R. V.
21.	Ring, Coupling	68.	Ring, Slideblock Spacer		
22.	Gear, G. P. Driving	69.	Screw, G. P. Cover	300.	Housing, Control
23.	Gear, G. P. Driven	70.	Gasket, G. P. Cover Screw	300A.	Screw, Sock Hd. Cap
24.	Bearing, Roller	71.	Gland, Oil Seal	301.	Piston, Control
25.	Shaft, Stub	72.	Housing, Gear Pump	302.	Packing, Block "Vee"
26.	Key, Drive Shaft	72A.	Screw, Sock. Hd. Cap	** 303.	Assembly, Relief Valve
27.	Seal, Oil	73.	Cover, Gear Pump	304.	Spacer, Adj.
28.	Gasket, Front Cover	74.	Screw, Slideblock Cover	304A.	Screw, Sock. Hd. Cap
29.	Gasket, G. P. Housing	75.	Head, Slideblock	305.	Screw, Adjusting
30.	Spacer, Bearing	76.	Tubing W/Fittings	306.	Seal, O'ring
31.	Gasket, Control Mtg.	77.	Key, Pintle	307.	Seal, O'ring
32.	Gasket, Control Adapter	78.	Gasket, Flange	308.	Seal, O'ring
33.	Gasket, Piston Screw	79.	Flange, Pipe	309.	Cap, Relief Valve
* 34.	Plunger, H. P. R. V.	79A.	Screw, Sock. Hd. Cap	309A.	Screw, Sock. Hd. Cap
* 35.	Bushing, H. P. R. V.	80.	Cover, Pintle End	310.	Cage, Spring
35A.	Plug, Bushing	80A.	Screw, Sock. Hd. Cap	311.	Guide, Spring
35B.	Seal, O'ring	81.	Gasket, Pintle Cover	312.	Seat, Relief Valve
35C.	Ring, Retaining	82.	Slideblock	313.	Body, Relief Valve
36.	Seal, O'ring	83.	Pin, Dowel	313A.	Screw, Sock. Hd. Cap
37.	Seal, O'ring	84.	Liner, Slideblock	314.	Spring, Relief Valve
38.	Cap, H. P. R. V.	84A.	Shims, Liner	315.	Ball, Hard. Steel
38A.	Screw, Sock. Hd. Cap	85.	Liner, Case	350.	Housing, Control
39.	Gasket, H. P. R. V.	86.	Pin, Dowel	350A.	Screw, Sock. Hd. Cap
40.	Screw, H. P. R. V. Adj.	87.	Bushing, Indicator	350B.	Screw, Sock. Hd. Cap
40A.	Nut, Adj. Screw Lock	88.	Stem, Indicator	351.	Gland, Control
41.	Guide, Spring	89.	Spring, Indicator	351A.	Screw, Sock. Hd. Cap
42.	Spring, H. P. R. V.	90.	Eye, Bolt	352.	Screw, Adjusting
43.	Guide, Spring	91.	Plate, Name	353.	Nut, Lock.
44.	Retainer, Bushing	92.	Screw, Drive	354.	Retainer
45.	Shim, Retainer	93.	Plate, Instruction	355.	Seal, O'ring
46.	Gasket, Aux. Port			356.	Seal, O'ring
47.	Flange, Aux. Port				

NOTE: When ordering replacement parts be sure to include pump serial number, data sheet (DS) number, and part number. Specify type of hydraulic fluid for O'rings, packings & Seals.

\* Parts Numbered 6 & 7, 34 & 35, 50 & 51 are furnished only as assemblies.

\*\* Part 303 is an Assembly.

O'RING SIZES  
( Cross Section x O.D. Duro ± 5)  
Pump Size

Part No.	8 - 12	20 - 35	60	Controls (All Sizes)
	Tapered Bushing H. P. R. V.			
36.	3/32 x 7/8 70	1/8 x 1 - 1/2 70	1/8 x 1 - 3/4 70	306. 3/16 x 1/2 70
37.	3/32 x 15/16 70	1/8 x 1 - 11/16 70	1/8 x 1 - 1 - 7/8 70	307. 3/32 x 5/8 70
	Straight Bushing H. P. R. V.			
37.	3/32 x 7/8 70	1/8 x 1 - 3/4 70	1 - 1/8 x 1 - 7/8 70	308. 3/32 x 3/4 70
	Sequence Type H. P. R. V.			
35B.			3/32 x 13/16 70	355. 3/32 x 15/16 90
37.			1/8 x 1 - 7/8 70	356. 1/8 x 1 - 1/4 90
	Suction Valve			
202.		3/16 x 3 - 7/8 90	1/8 x 4 - 5/8 90	
203.		3/16 x 2 - 3/4 90	3/16 x 3 - 5/8 90	
208.		1/8 x 3 - 1/2 90		
217.		1/8 x 1 - 7/16 90		