

# PARTS DRAWING SPECIAL "DXP" PUMP

OIL CIRCUIT DS-947829  
COOLER INSTALLATION  
DRAWING DS-47905  
COOLER OIL CIRCUIT  
DS-947905

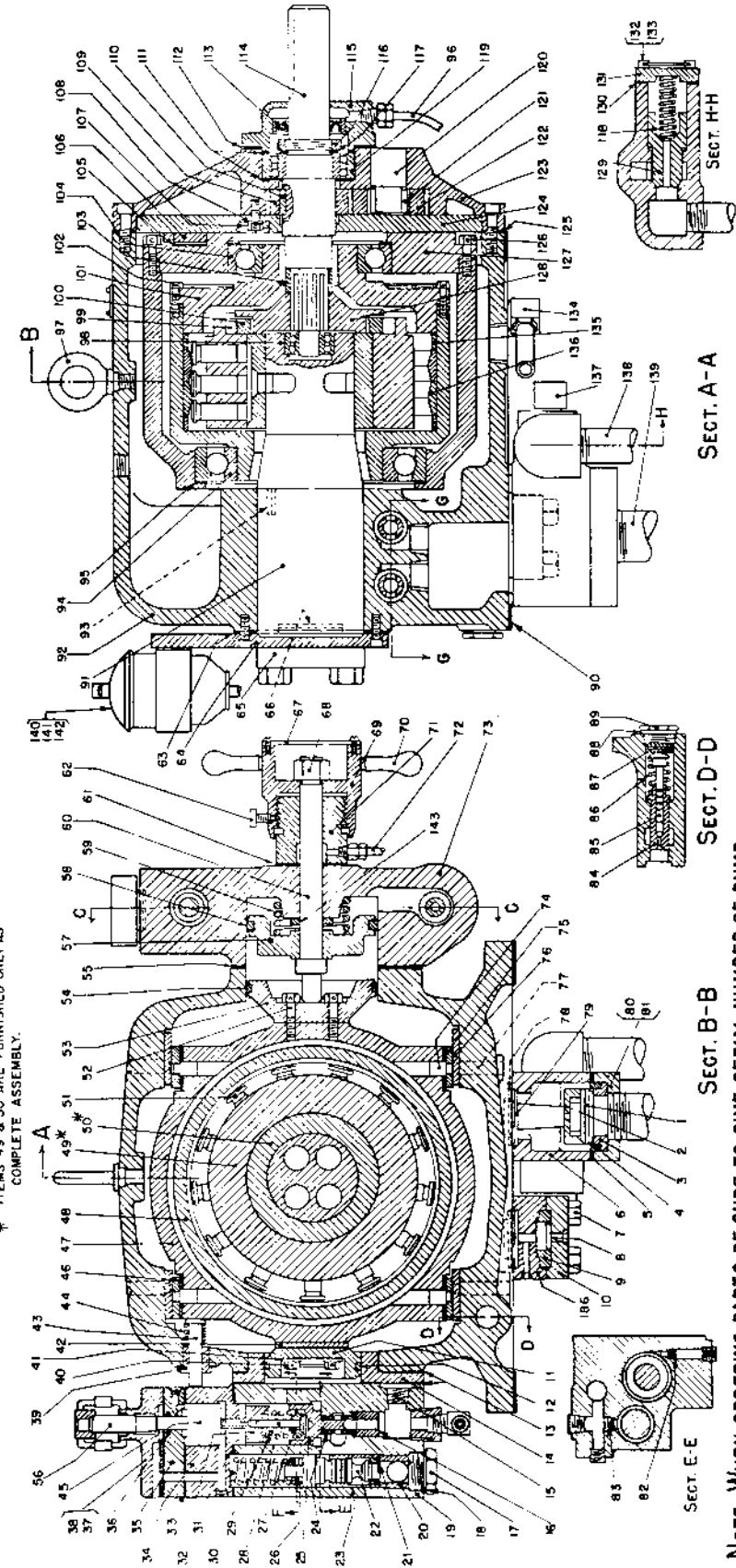

57963

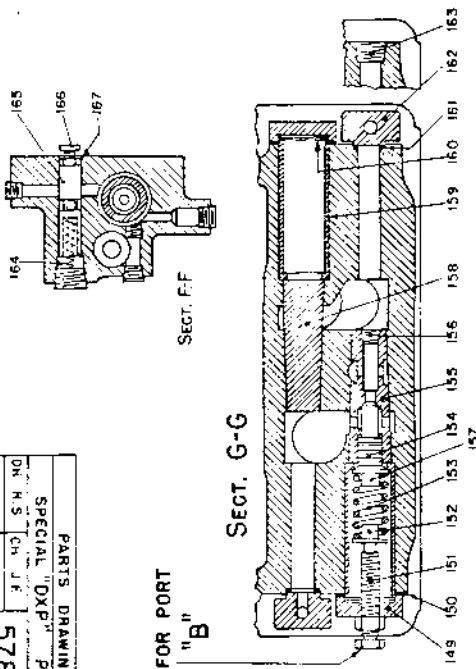
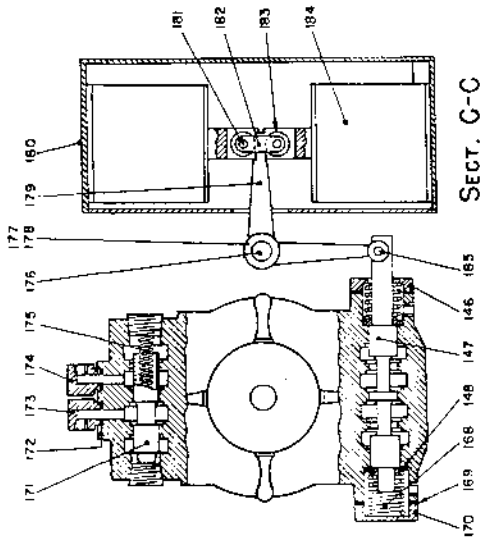
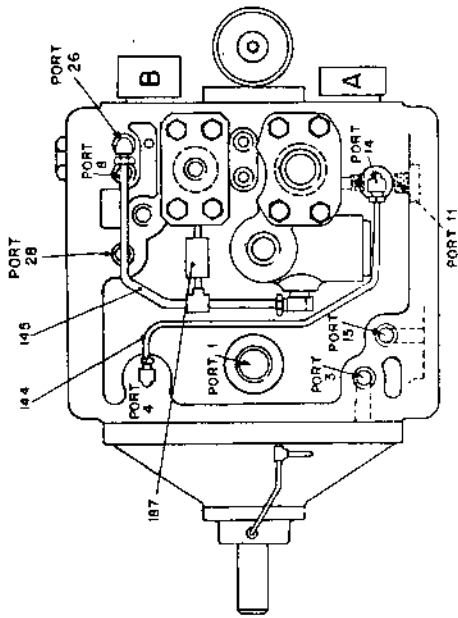

\* ITEMS 49 & 50 ARE FURNISHED ONLY AS COMPLETE ASSEMBLY.

57963	Part 2
CH J.F.	1/24/51
DN H.S.	
PARTS DRAWING SPECIAL "DXP" PUMP	

NOTE: WHEN ORDERING PARTS BE SURE TO GIVE SERIAL NUMBER OF PUMP

PARTS LIST  
OILGEAR SPECIAL "DXP" PUMPS

NO.	PARTS	NO.	PARTS	NO.	PARTS
1.	Disc, Check Valve	63.	Gasket, Pintle Cover	124.	Cover, Gear Pump
2.	Cage, Check Valve	64.	Cover, Pintle	125.	Gasket, G.P. Housing
3.	Seat, Check Valve	65.	Flange, Connection	126.	Screw, Slide Block Cover
4.	Spacer, Check Valve	66.	Gasket, Flange	127.	Cover, Slide Block
5.	Gasket, Suction Flange	67.	Plate, Knob Cover	128.	Flange, Coupling
6.	Housing, Suction Valve	68.	Nut, Stroke Adj. Screw	129.	Plunger, B.P.R.V.
7.	Screw, Flange	69.	Knob, "DX" Control	130.	Gasket, B.P.R.V. Cap
8.	Disc, Check Valve	70.	Handle, Control Knob	131.	Cap, B.P.R.V.
9.	Cage, Check Valve	71.	Gland, "DX" Control	132.	Screw, Cap
10.	Flange, Check Valve	72.	Tubing, Control Gland	133.	Wire, Lock
11.	Piston, Small Control	73.	Housing, "DX" Control	134.	Ell, Ports 4 and 14
12.	Ring, Small Control Piston	74.	Dowel, Slide Block Liner	135.	Spacer, Thrust Ring
13.	Gasket, "DP" Control	75.	Liner, Slide Block	136.	Ring, Thrust
14.	Adapter, Control Piston	76.	Liner, Case	137.	Ell, Ports 22 and 26
15.	Plug, Pipe	77.	Dowel, Case Liner	138.	Tube, B.P.R.V. Discharge
16.	Retainer, Guide	78.	Gasket, Suction Valve	139.	Tube, Suction
17.	Cap, Peak Relief Valve	79.	Spacer, Suction Valve	140.	Filter Oil
18.	Gasket, Cap	80.	Flange, Suction	141.	Valve, Flow Control
19.	Housing, "DP" Control	81.	Screw, Suction Flange	142.	Gage, Change Indicator
20.	Spacer, Peak Relief Valve	82.	Plug, Pipe	143.	Spacer, Neutral Stop
21.	Seat, Peak Relief Valve	83.	Plug, Pipe	144.	Tubing, Port 4 to 14
22.	Plunger, Peak Relief Valve	84.	Plunger, G.P.R.V.	145.	Tubing, Port 22 to 26
23.	Sleeve, Peak Relief Valve	85.	Plunger, G.P.R.V. Dashpot	146.	Cap, Pilot Valve
24.	Guide, Unloading Valve	86.	Spring, G.P.R.V.	147.	Plunger, Pilot Valve
25.	Plunger, Unloading Valve	87.	Shim, G.P.R.V.	148.	Seat, Pilot Valve Spring
26.	Shim, Peak Relief Valve	88.	Gasket, G.P.R.V. Cap	149.	Cap, H.P.R.V.
27.	Seat, Unloading V. Spring	89.	Cap, G.P.R.V.	150.	Gasket, Cap
28.	Guide, Unloading V. Spring	90.	Gasket, Oil Reservoir	151.	Screw, H.P.R.V. Adj.
29.	Spring, Unloading Valve	91.	Pintle	152.	Guide, H.P.R.V. Spring
30.	Spring, Peak Relief Valve	92.	Case	153.	Spring, H.P.R.V.
31.	Gasket, "DP" Control Head	93.	Key, Pintle	154.	Plunger, H.P.R.V.
32.	Guide, Unloading Valve Stem	94.	Bearing, Rear Rotor	155.	Bushing, H.P.R.V.
33.	Gasket, Spring Cover	95.	Shim, Rear Rotor Bearing	156.	Plug, Pipe
34.	Cover, Spring	96.	Drain, Shaft Seal	157.	Seat, H.P.R.V. Spring
35.	Spacer, Bracket	97.	Eyebolt	158.	Plug, H.P.R.V. Dummy
36.	Packing, O' Ring	98.	Bearing, Rear Shaft	159.	Retainer, H.P.R.V. Bushing
37.	Bracket, Adjusting Screw	99.	Roller, Coupling	160.	Shim, Retainer
38.	Screw, Bracket Mounting	100.	Ring, Coupling	161.	Gasket, Flange
39.	Bushing, Indicator	101.	Cover, Rotor	162.	Flange, H.P.R.V. Blind
40.	Screw, Small Piston	102.	Screw, Rotor Cover	163.	Plug, H.P.R.V. Blind
41.	Gasket, Piston Screw	103.	Spacer, Coupling	164.	Spring, Neut. Stop Plunger
42.	Spacer, Piston	104.	Bearing, Front Rotor	165.	Plunger, Neutral Stop
43.	Stem, Indicator	105.	Shim, Spacer Ring	166.	Screw, Neut. Stop Adj.
44.	Spring, Indicator	106.	Ring, Slide Block Spacer	167.	Nut, Neut. Stop Lock
45.	Piston, Dual Pressure	107.	Screw, Gear Pump Cover	168.	Spring, Pilot Valve
46.	Shim, Slide Block Liner	108.	Gasket, G.P. Cover Screw	169.	Gasket, Flange
47.	Slide Block	109.	Gear, G.P. Driver	170.	Flange, Pilot Valve
48.	Rotor	110.	Key, G.P. Driver	171.	Plunger, Bypass Valve
49.	Cylinder*	111.	Shim, Front Shaft Bearing	172.	Gasket, Flange
50.	Bushing, Cylinder*	112.	Gasket, Shaft Seal Housing	173.	Flange, Pipe
51.	Piston	113.	Seal, Shaft Oil	174.	Flange, Pipe
52.	Screw, Large Piston	114.	Shaft, Drive	175.	Spring, Bypass Valve
53.	Piston, Large Control	115.	Housing, Shaft Seal	176.	Pin, Solenoid Lever
54.	Ring, Large Piston	116.	Nut, Bearing Lock	177.	Collar, Solenoid Lever
55.	Gasket, "DX" Control	117.	Washer, Bearing Lock	178.	Bushing, Solenoid Lever
56.	Screw, "DP" Control	118.	Spring, B.P.R.V.	179.	Lever, Solenoid
57.	Piston, "DX" Control	119.	Bearing, Front Shaft	180.	Cover, Solenoid
58.	Ring, "DX" Piston	120.	Shaft, G.P. Stub	181.	Pin, Solenoid Link
59.	Spring, "DX" Piston	121.	Bearing, G.P. Roller	182.	Link, Solenoid
60.	Screw, Stroke Adjusting	122.	Gear, G.P. Driven	183.	Roller, Solenoid
61.	Gasket, Control Gland	123.	Housing, Gear Pump	184.	Solenoid
62.	Screw, Control Knob Lock			185.	Pin, Pilot Valve Plunger
				186.	Spacer, Check Valve
				187.	Valve, Kohler Check

\*Parts 49 and 50 furnished only as a complete assembly.

NOTE: When ordering parts be sure to give serial number of pump.