

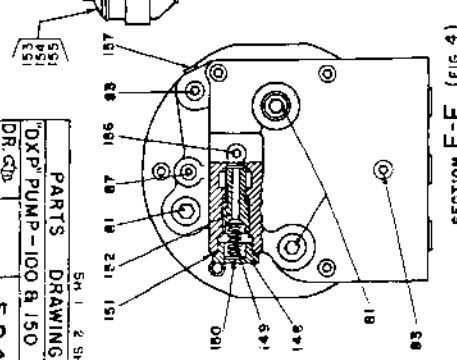

OILGEAR TYPE "DXP-100" & "DXP-150" PUMPS

SH. I
98439

CH. CUB.	APPE. (U.)
DR. CUB.	APPE. (U.)
PARTS DRAWING	
DXP PUMP-100 & 150 H.P.	
SH. I & SH. 2	
58439	

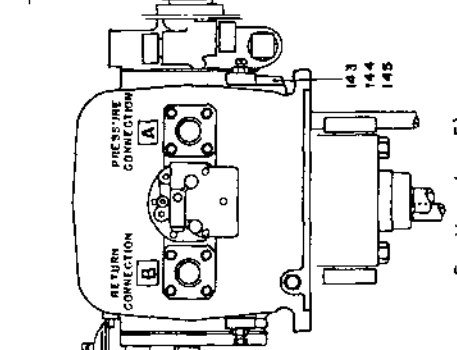
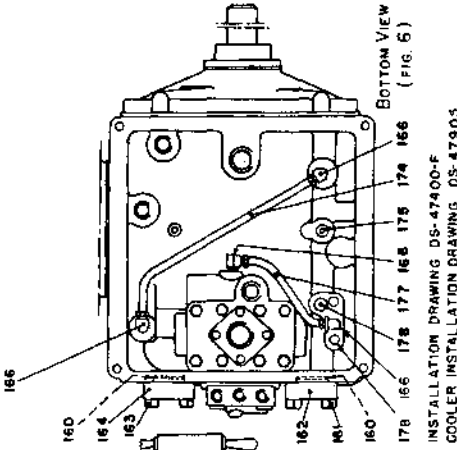
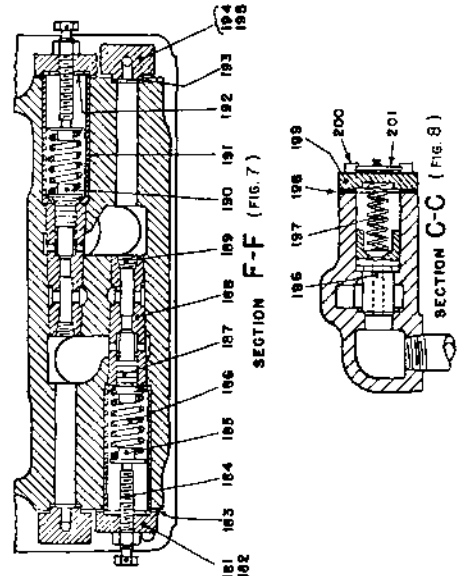

INSTALLATION DRAWING DS-47400-F
 COOLER INSTALLATION DRAWING DS-47905
 PINTLE OIL CIRCUIT DS-947025
 COOLER OIL CIRCUIT DS-947906

SECTION E-E (FIG. 4)
 * ITEMS 33, 34 ARE FURNISHED ONLY AS COMPLETE ASSEMBLY

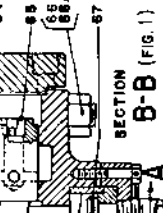
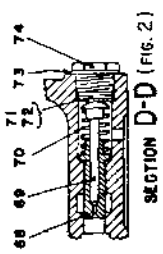
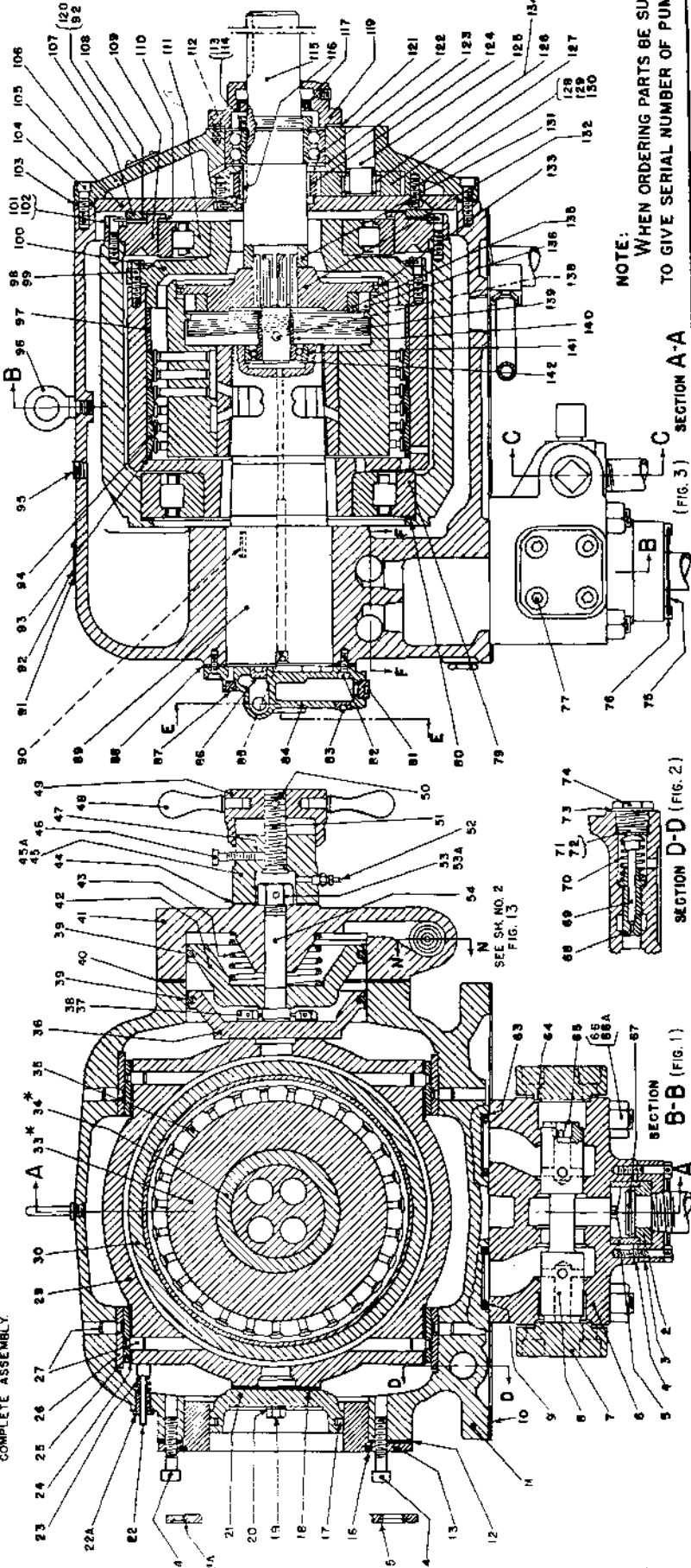

NOTE:
 WHEN ORDERING PARTS BE SURE
 TO GIVE SERIAL NUMBER OF PUMP.

PARTS LIST
OILGEAR TYPE DXP-100 AND 150 PUMPS
(also see sheet #2)

NO.	PARTS	NO.	PARTS	NO.	PARTS
2.	Seat, Valve, Check	57.	Disc. Valve, Check	128.	Screw, G. P. Cover
3.	Flange, Suction	58.	Plunger, Valve, G.P. Relief	129.	Gasket, Cover Screw
4.	Gasket, Suction: Flange	59.	Plunger, Dashpot, Relief Valve	130.	Wire, Lock
5.	Cage, Valve Check	70.	Spring, Valve, Relief Valve	131.	Spacer, Coupling
6.	Body, Valve	71.	Spacer, Valve, G.P. Relief	132.	Flange, Coupling
7.	Head, Valve, Suction	72.	Shim, Valve, G.P. Relief	133.	Ring, Piston
8.	Plunger, Valve, Suction	73.	Gasket, Cap, Valve	134.	Spacer, Bearing
9.	Gasket, "O" Ring, Valve	74.	Cap, Valve, G.P. Relief	135.	Ring, Coupling
10.	Gasket, Oil Reservoir	75.	Wire, Lock	136.	Roller, Coupling
11.	Case, Pump	76.	Screw, Suction Flange	138.	Ball, Flat Spring
12.	Gasket, Adapter, Control	77.	Screw, Cap, Socket Head	139.	Spring, Flat
13.	Adapter, Cylinder, Control	79.	Bearing, Rear Rotor	140.	Yoke, Flat Spring
14.	Screw, Cap, Socket Head	80.	Shim, Bearing, Rear Rotor	141.	Bearing, Rear Shaft
15.	Gasket, Adapter, Control	81.	Plug, Pipe	142.	Shim, Rear Shaft Bearing
16.	Gasket, Adapter, Control	82.	Screw, Mounting, Pintle Cover	143.	Flange, Blind
17.	Ring, Piston, Control	83.	Plug, Pipe	144.	Screw, Flange
18.	Spacer, Piston, Control	84.	Cover, Pintle	145.	Gasket, Flange
19.	Screw, Cap, Hex. Head	85.	Orifice, Pintle	148.	Cap, Pintle Cover R.V.
20.	Gasket, Screw, Control	86.	Plug, Pipe, Pintle Cover	149.	Spring, Pintle Cover R.V.
21.	Piston, Control	87.	Plug, Pipe, Pintle Cover	150.	Shim, Pintle Cover R.V.
21A	Gasket, "O" Ring, Adapter, Control	88.	Gasket, Pintle Cover	151.	Gasket, Cap
22.	Stem, Indicator, Stroke	89.	Pintle, Pump	152.	Plunger, Pintle Cover R.V.
22A	Bushing, Indicator, Stroke	90.	Key, Pintle, Pump	153.	Filter, Oil
23.	Spring, Indicator, Stroke	91.	Nameplate, Pump	154.	Valve, Flow Control
24.	Shim, Slide Block	92.	Screw, Drive, Nameplate	155.	Gage, Change Indicator
25.	Liner, Slide Block	93.	Ring, Spacer, Pump	156.	Plug, Pipe
26.	Liner, Case, Pump	94.	Ring, Thrust, Pump	157.	Plug, Pipe
27.	Dowel, Liner, Slide Block	95.	Plug, Pipe	160.	Flange, Gasket
29.	Slide Block, Pump	96.	Eyebolt, Pump	161.	Bolt, Flange
30.	Rotor, Pump	97.	Spacer, Thrust Ring	162.	Flange, Pump
33.	Cylinder, Pump	98.	Screw, Cap, Slide Block	163.	Bolt, Flange
34.	Bushing, Cylinder	99.	Wire, Lock	164.	Flange, Pump
35.	Piston, Pump	100.	Cover, Rotor, Pump	166.	Elbow, Pipe
36.	Piston, Control	101.	Screw, Slide Block Cover	174.	Tube, G.P. Pressure
37.	Screw, Piston, Control	102.	Wire, Lock	175.	Plug, Pipe
38.	Gasket, Screw, Control Piston	103.	Gasket, Gear Pump Housing	177.	Tube, Back Pressure
39.	Ring, Piston, Control	104.	Screw, Gear Pump Housing	178.	Plug, Pipe
40.	Gasket, Head, Control	105.	Cover, Gear Pump	181.	Cap, H.P.R.V.
41.	Head, Cylinder, Control	106.	Housing, Gear Pump	182.	Screw, Cap
42.	Piston, Control	107.	Ring, Slide Block Spacer	183.	Gasket, H.P.R.V. Cap
43.	Spring, Control	108.	Shim, Slide Block Spacer	184.	Screw, H.P.R.V. Adj.
44.	Gasket, Gland, Control	109.	Cover, Slide Block	185.	Seat, H.P.R.V. Spring
45.	Gland, Control	110.	Shim, Front Rotor Bearing	186.	Spring, H.P.R.V.
45A	Screw, Cap, Socket Head	111.	Bearing, Front Rotor	187.	Plunger, H.P.R.V.
46.	Screw, Thumb	112.	Screw, Seal Housing	188.	Bushing, H.P.R.V.
47.	Plug, Brass	113.	Nut, Bearing Lock	189.	Plug, Pipe
48.	Handle, Control	114.	Washer, Bearing Lock	190.	Seat, H.P.R.V. Spring
49.	Knob, Adjusting	115.	Shaft, Drive	191.	Retainer, H.P.R.V. Bushing
50.	Pin, Taper	116.	Key, Gear Pump Drive	192.	Shim, H.P.R.V. Cap
51.	Screw, Adjusting	117.	Seal, Shaft Oil	193.	Gasket, Flange
52.	Fitting, Ermeto	119.	Housing, Shaft Seal	194.	Flange, Auxiliary
53.	Nut, Screw, Adjusting	120.	Direction Plate, Rotation	195.	Screw, Flange
53A	Pin, Screw, Adjusting	121.	Gasket, Seal Housing	196.	Plunger, B.P.R.V.
54.	Screw, Adjusting, Neutral Stop	122.	Bearing, Front Shaft	197.	Spring, B.P.R.V.
63.	Spacer, Valve, Suction	123.	Shim, Front Shaft Bearing	198.	Gasket, Cap
64.	Gasket, Head, Valve	124.	Gear, Gear Pump Driver	199.	Cap, B.P.R.V.
65.	Plug, Choke, Valve	125.	Shaft, G. P. Stub	200.	Screw, Cap
66.	Stud, Valve, Suction	126.	Bearing, G. P. Needle	201.	Wire, Lock
66A	Nut, Hex	127.	Gear, G. P. Driven		

* Parts 33 and 34 furnished only as a complete assembly.

NOTE: When ordering parts be sure to give serial number of pump.