



SPECIAL "DX" TWO WAY VARIABLE DELIVERY PUMPS WITH STROKE CONTROL ON "B" SIDE

505505

505005
 DR. 4/7/58
 SPEC. TYPE "DX" 2-WAY
 PUMPS
 S/NIMVNO S1RV
 OIL CIRCUIT DS-947835
 COOLER INSTALLATION
 DS-47905
 CODLER OIL CIRCUIT
 DS-947906

NOTE:
 WHEN ORDERING PARTS, BE SURE TO
 INCLUDE SERIAL NUMBER OF PUMP,
 DATA SHEET NUMBER B PART NUMBER,
 PARTS *67, *34 & *35, B *50 & *51 ARE
 FURNISHED AS A COMPLETE ASSEM-
 BLY ONLY.

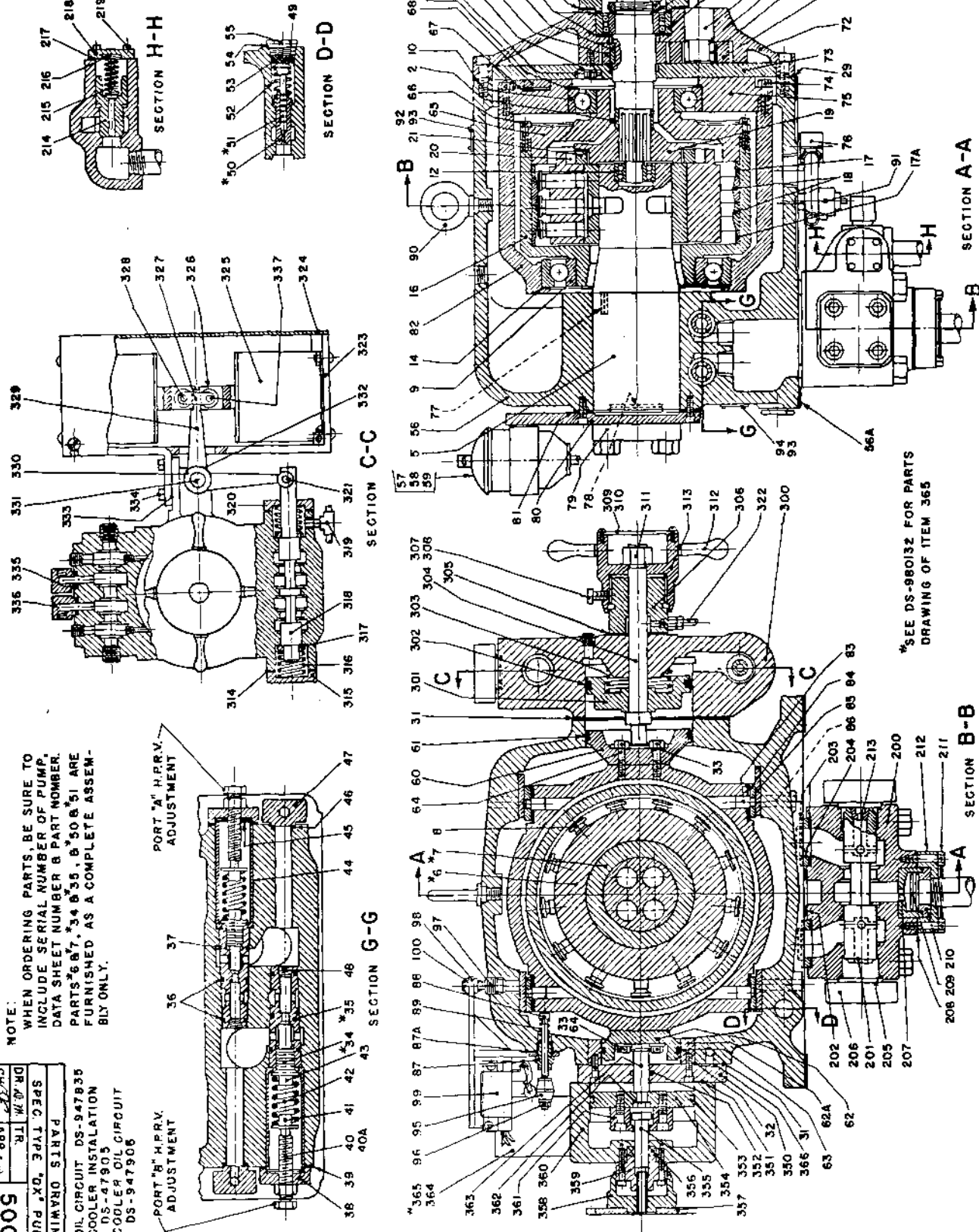

*SEE DS-980132 FOR PARTS
DRAWING OF ITEM 365

MADE IN U.S.A.

ISSUED APR. 11, 1958

THE OILGEAR COMPANY
MILWAUKEE 4, WISCONSIN, U.S.A.

DS-947834

PARTS LIST
OILGEAR SPECIAL "DX" PUMP

PART NO.	DESCRIPTION	PART NO.	DESCRIPTION	PART NO.	DESCRIPTION
1.	Shaft, Drive	61.	Ring, Piston	213.	Flange, B.P.R.V.
2.	Spacer, Coupling	62.	Piston, Control	219.	Screw, B.P.R.V. Flange
3.	Nut, Lock	62A.	Adapter, Control Piston		
4.	Washer, Lock	63.	Ring, Piston		
5.	Pintle	64.	Screw, Control Piston		
*6.	Cylinder	65.	Head, Rotor	300.	Housing, Control
*7.	Bushing, Cylinder	66.	Screw, Rotor Head	301.	Piston, Control
8.	Piston	67.	Shims, Slide Block Cover	302.	Ring, Piston
9.	Bearing, Rear Rotor	68.	Ring, Slide Block Spacer	303.	Spring, Piston
10.	Bearing, Front Rotor	69.	Screw, G.P. Cover	304.	Screw, Stroke Adjustment
11.	Bearing, Front Dr. Shaft	70.	Gasket, G.P. Cover Screw	305.	Gasket, Gland
12.	Bearing, Rear Dr. Shaft	71.	Housing, Shaft Seal	306.	Gland, Adj. Screw
13.	Shims, Front Rotor Bearing	72.	Housing, Gear Pump	307.	Screw, Thumb
14.	Shims, Rear Rotor Bearing	73.	Cover, G.P.	308.	Washer, Thumb Screw
15.	Shims, Frt. Dr. Shaft Brg.	74.	Screw, Slide Block Head	309.	Cover, Control Knob
16.	Rotor	75.	Head, Slide Block	310.	Gasket, Cover
17.	Ring, Spacer	76.	Tubing, G.P.	311.	Nut, Adj. Screw Lock
17A.	Ring, Spacer	77.	Key, Pintle	312.	Handle, Control
18.	Ring, Thrust	78.	Gasket, Flange	313.	Knob, Control
19.	Flange, Coupling	79.	Flange, Pipe	314.	Gasket, Head
20.	Roller, Coupling	80.	Cover, Pintle End	315.	Head, Pilot Valve End
21.	Ring, Coupling	81.	Gasket, Pintle Cover	316.	Spring, Pilot Valve
22.	Gear, G.P. Driving	82.	Slideblock	317.	Seat, Spring
23.	Gear, G.P. Driven	83.	Dowel, Slide Block Liner	318.	Plunger, Pilot Valve
24.	Bearing, Roller	84.	Liner, Slide Block	319.	Fitting, Ermeto
25.	Shaft, Stub	85.	Liner, Case	320.	Head, Valve
26.	Key, Drive Shaft	86.	Dowel, Case Liner	321.	Pin, Lever
27.	Seal, Dr. Shaft Oil	87.	Bushing, Indicator	322.	Fitting, Ermeto
28.	Gasket, Front Cover	87A.	Spacer, Indicator Bushing	323.	Bracket, Solenoid Mounting
29.	Gasket, G.P. Housing	88.	Stem, Indicator	324.	Cover, Solenoid
30.	Spacer, Bearing	89.	Spring, Indicator	325.	Solenoid, Pull Type
31.	Gasket, Control Cylinder	90.	Eye Bolt	326.	Roller, Solenoid
32.	Gasket, Control Cyl. Adapter	91.	Valve, Relief 10 psi	327.	Link, Solenoid
33.	Gasket, Piston Screw	92.	Plate, Name	328.	Pin, Solenoid
*34.	Plunger, H.P.R.V.	93.	Screw, Drive	329.	Lever, Operating
*35.	Bushing, H.P.R.V.	94.	Plate, Name	330.	Bushing, Oilite
36.	Packing, O'Ring	95.	Sleeve, Indicator tapered	331.	Pin, Operating Lever
37.	Packing, O'Ring	96.	Nut, Lock	332.	Collar, Lever
38.	Cap, Relief Valve	97.	Stud, Mounting	333.	Shim, Solenoid Bracket
39.	Gasket, R.V. Cap	98.	Bracket, Micro Sw. Mtg.	334.	Screw, Hex. Hd. Cap
40.	Screw, Adjusting	99.	Switch, Micro	335.	Gasket, Flange
40A.	Nut, Adj. Screw Lock	100.	Nut, Lock	336.	Flange
41.	Guide, Spring			337.	Nut, Lock
42.	Spring, H.P.R.V.				
43.	Guide, Spring				
44.	Retainer, Bushing	200.	Body, Suction Valve		
45.	Shims, Retainer	201.	Plunger, Suction Valve	350.	Head, Control Cylinder
46.	Packing, O'Ring	202.	Gasket, H.P. Exhaust	351.	Gasket, Control Cyl. Hd.
47.	Cap, Aux. Port	203.	Gasket, Spacer	352.	Packing, O'Ring
48.	Plug, Pipe	204.	Spacer, Suction Valve	353.	Ring, Piston
49.	Spacer, G.P.R.V.	205.	Gasket, Flange	354.	Piston, Control
*50.	Plunger, Dashpot	206.	Flange, Suction Valve	355.	Screw, Adjusting
*51.	Plunger, G.P.R.V.	207.	Cage, Check Valve	356.	Packing, Chevron
52.	Spring, G.P.R.V.	208.	Gasket, Check Valve	357.	Sprocket, Drive
53.	Shims, G.P.R.V.	209.	Disc, Check Valve	358.	Knob, Control
54.	Gasket, G.P.R.V. Cap	210.	Seat, Check Valve	359.	Gland, Control
55.	Cap, G.P.R.V.	211.	Screw, Check Valve Flange	360.	Head, Control
56.	Case	212.	Flange, Suction	361.	Plate, Control Stop
56A.	Gasket, Reservoir	213.	Plug, Choke	362.	Ring, Retaining
57.	Filter, Oil	214.	Plunger, B.P.R.V.	363.	Stem, Control
58.	Valve, Flow Control	215.	Spring, B.P.R.V.	364.	Packing, O'Ring
59.	Gage, Filter	216.	Shim, B.P.R.V.	365.	Valve, 3/8" N.C. (See DS-980132)
60.	Piston, Control	217.	Gasket, B.P.R.V. Flange	366.	Plug, Orifice

*NOTE: Part numbers 6 & 7, 34 & 35, 50 & 51 furnished as a complete assembly only.

When ordering replacement parts be sure to include serial number of pump and data sheet number.

When ordering replacement O'Rings specify type of Hydraulic Fluid.