

OILGEAR SPECIAL TYPE "X" CONTROL FOR TYPE "D" PUMPS

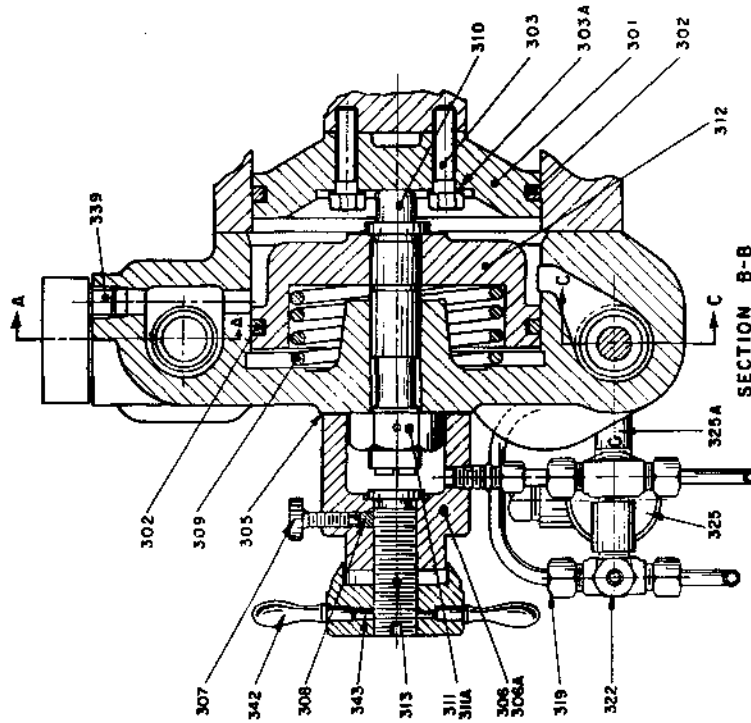

NOTE:
WHEN ORDERING REPLACEMENT PARTS; BE SURE TO
INCLUDE UNIT SERIAL No., DATA SHEET (DS) No. B.
PART No.; SPECIFY TYPE OF HYDRAULIC FLUID FOR
O-RINGS & SEALS.

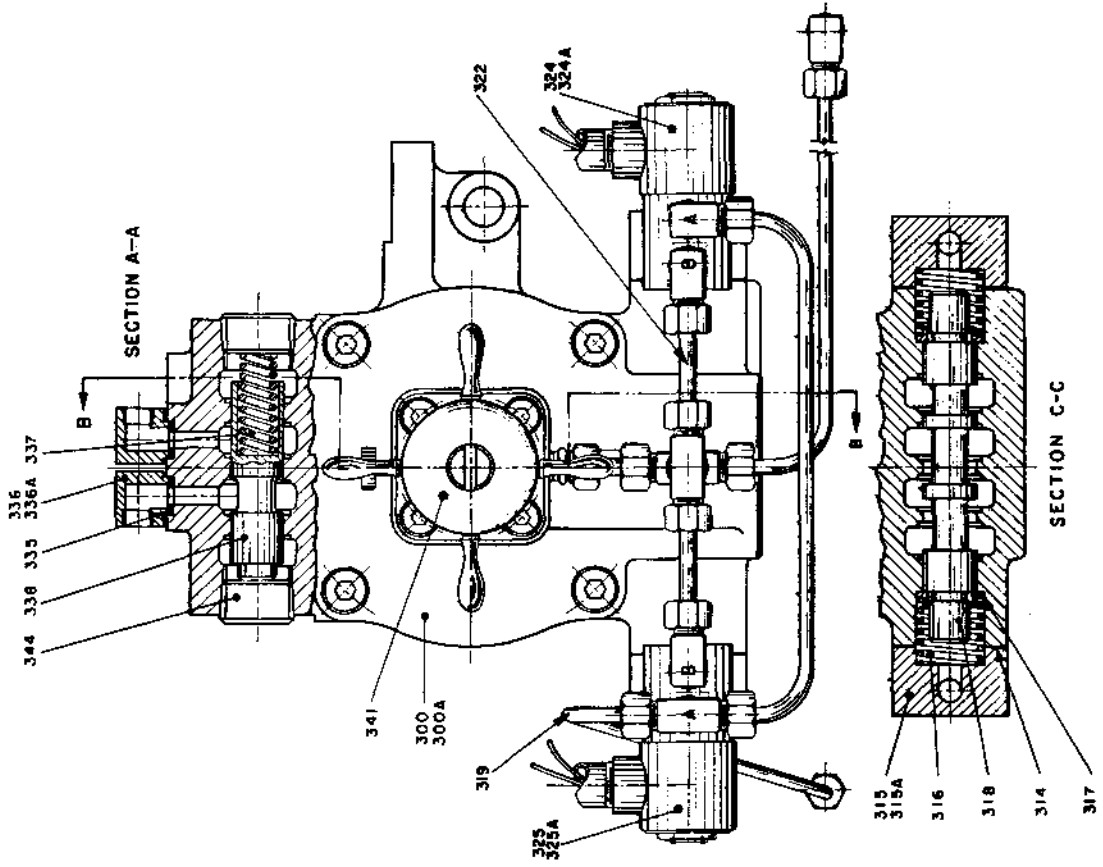

SHEET 2 OF 2 SHEETS	
PARTS DRAWING ANEITER	
SPECIAL TYPE "X" CONT.-TYPE D	
DR. E.T. CH. AL.	503365
TR. APP. AT	

ISSUED-DEC., 1961.

THE OILGEAR COMPANY
MILWAUKEE 4, WISCONSIN, U.S.A.

SHEET 2 OF 2 SHEETS
DS-947836

PRINTED IN U.S.A. 503365

PARTS LIST
OILGEAR SPECIAL TYPE "K" CONTROL FOR
TYPE "D" PUMPS

Part No.	Description	Part No.	Description
300.	Housing, Control	315A.	Screw, Sock. Hd. Cap
300A.	Screw, Sock. Hd. Cap	316.	Spring, Pilot Valve
301.	Piston, Control	317.	Seat, Valve Spring
302.	Ring, Piston	318.	Plunger, Pilot Valve
303.	Screw, Control Piston	319.	Tubing w/ fittings
303A.	Gasket, Screw	322.	Tubing w/ fittings
304.	Wire, Lock	324.	Valve, Skinner
305.	Gasket, Gland	324A.	Nipple, Pipe
306.	Gland, Adj. Screw	325.	Valve, Skinner
306A.	Screw, Sock. Hd. Cap	325A.	Nipple, Pipe
307.	Screw, Thumb	335.	Gasket, Flange
308.	Plug, Brass	336.	Flange, Bypass
309.	Spring, Neutral Piston	336A.	Screw, Sock. Hd. Cap
310.	Screw, Adjusting	337.	Spring, Bypass Valve
311.	Nut, Lock	338.	Plunger, Bypass
311A.	Pin, Dowel	339.	Plug, Pipe
312.	Piston, Neutral Control	341.	Knob, Control
313.	Screw, Adjusting	342.	Handle, Control Knob
314.	Gasket, End Head	343.	Pin, Taper
315.	Head, Pilot Valve End	344.	Cap, Bypass Valve

NOTE: When ordering replacement parts be sure to include serial number, data sheet (DS) number and part number. Specify type of hydraulic fluid for O' rings, packings and seals.



OILGEAR SPECIAL TYPE "DXR" VARIABLE DELIVERY PUMP

593365
 TR. APR 67
 OR. E. F. CH. 40
 TYPE "DX" PUMP - AMETER
 PARTS DRAWING
 SHEET 1 OF 2 SHEETS

COOLER INSTALLATION DRAWING DS-47905
 COOLER CIRCUIT DRAWING DS-947906 (TWO-WAY PUMPS)
 DS-947908 (ONE-WAY PUMPS)

NOTE: WHEN ORDERING PARTS, BE SURE TO INCLUDE SERIAL NUMBER, PART NUMBER, AND DATA SHEET NUMBER. SPECIFY TYPE OF HYDRAULIC FLUID FOR O-RING AND SEALS.

PARTS # 6, 7, 34 B, 35, 50 B, 51 FURNISHED AS A COMPLETE ASSEMBLY ONLY.

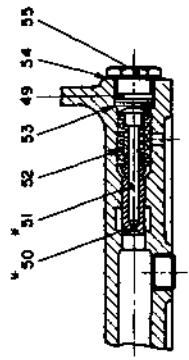

SECTION D-D

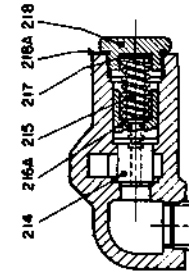

SECTION E-E

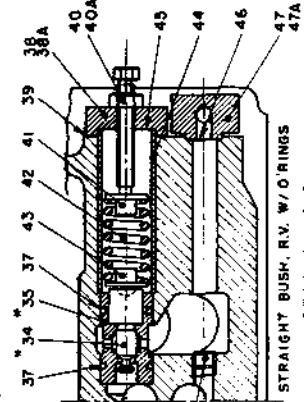

SECTION C-C

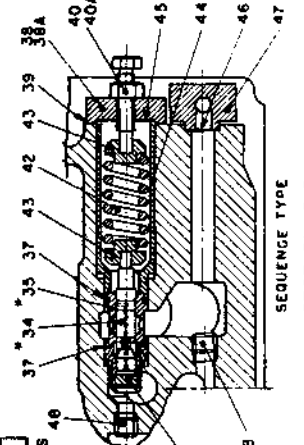

SECTION C-C

NOTE: PUMPS WITH SEQUENCE TYPE RELIEF VALVE, PART NUMBERS 34, 8, 35, A, B, C, FURNISHED AS AN SSC ASSEMBLY.

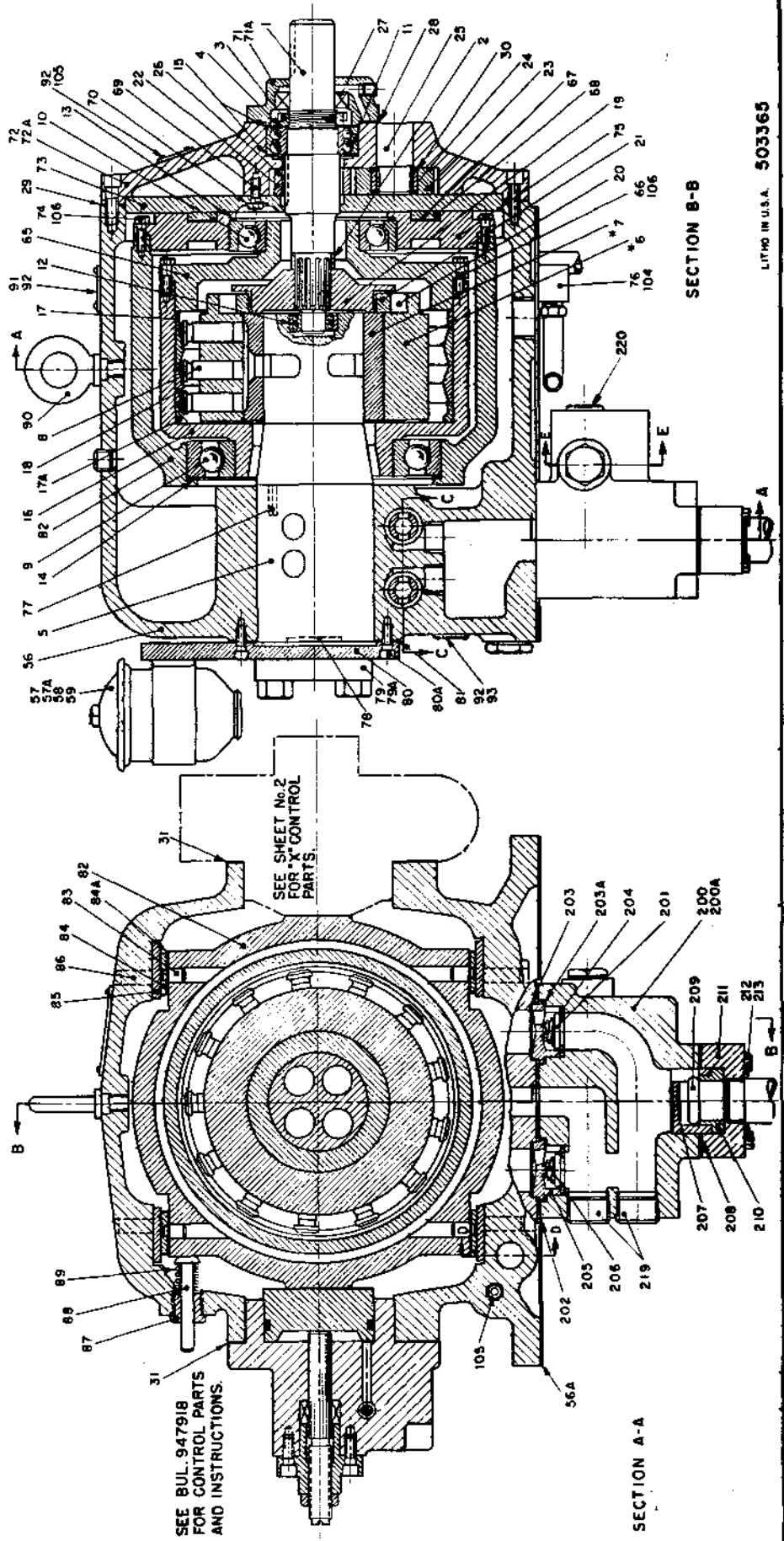

SECTION B-B

SECTION A-A

LIT. NO. IN U.S.A. 503365

PARTS LIST
OILGEAR SPECIAL TYPE "DX" VARIABLE DELIVERY PUMPS

Part No.	Description	Part No.	Description	Part No.	Description
1.	Shaft, Drive	41.	Guide, Spring	81.	Gasket, Pintle Cover
2.	Spacer, Coupling	42.	Spring, H. P. R. V.	82.	Slideblock
3.	Nut, Lock	43.	Guide, Soring	83.	Pin, Dowel
4.	Washer, Lock	44.	Retainer, Busing	84.	Liner, Slideblock
5.	Pintle	45.	Shims, Retamer	84A.	Shims, Liner
*6.	Cylinder	46.	Gasket, Aux. Port	85.	Liner, Case
*7.	Bushing, Cylinder	47.	Cap, Aux. Port	86.	Pin, Dowel
8.	Piston, Radial	47A.	Screw, Sock. Hd. Cap	87.	Bushing, Indicator Stem
9.	Bearing, Rear Rotor	48.	Plug, Pipe	88.	Stem, Stroke Indicator
10.	Bearing, Front Rotor	49.	Spacer, G. P. R. V.	89.	Spring, Indicator Stem
11.	Bearing, Front Dr. Shift.	*50.	Plunger, Dashpot	90.	Eyebolt
12.	Bearing, Rear Dr. Shift.	*51.	Plunger, G. P. R. V.	91.	Plate, Name
13.	Shims, Frt. Rotor Brg.	52.	Spring, G. P. R. V.	92.	Screw, Drive
14.	Shims, Rear Rotor Brg.	53.	Shims, G. P. R. V.	93.	Plate, Cooler Inst.
15.	Shims, Frt. Dr. Shift. Brg.	54.	Gasket, G. P. R. V. Cap	104.	Tubing w/Fittings
16.	Rotor	55.	Cap, G. P. R. V.	105.	Plate, Rot. Name
17.	Ring, Spacer	56.	Case, Pump	106.	Wire, Lock
17A.	Ring, Spacer	56A.	Gasket, Pump Mtg.		
18.	Ring, Thrust	57.	Assembly, Oil Filter	200.	Body, Suction Valve
19.	Flange, Coupling	57A.	Element, Filter	200A.	Screw, Sock. Hd. Cap
20.	Roller, Coupling	58.	Valve, Flow Control	201.	Disc, Check Valve
21.	Ring, Coupling	59.	Gage, Filter	202.	Gasket, Suction Valve
22.	Gear, G. P. Driving			203.	Gasket, Upper Cage
23.	Gear, G. P. Driven	65.	Head, Rotor	203A.	Gasket, Lower Cage
24.	Bearing, Roller	66.	Screw, Rotor Head	204.	Seat, Check Valve
25.	Shaft, Stub	67.	Shims, Slideblock Cover	205.	Cage, Check Valve
26.	Key, Drive Shaft	68.	Ring, Slideblock Spacer	206.	Spring, Check Valve
27.	Seal, Oil	69.	Screw, G. P. Cover	207.	Cage, Check Valve
28.	Gasket, Seal Gland	70.	Gasket, G. P. Cover Screw	208.	Gasket, Suction Flange
29.	Gasket, G. P. Housing	71.	Gland, Oil Seal	209.	Disc, Suct. Check Valve
30.	Spacer, Bearing	71A.	Screw, Sock Hd. Cap	210.	Seat, Check Valve
31.	Gasket, Control Mount.	72.	Housing, Gear Pump	211.	Flange, Suction
*34.	Plunger, H. P. R. V.	72A.	Screw, Sock. Hd. Cap	212.	Screw, Sock. Hd. Cap
*35.	Bushing, H. P. R. V.	73.	Cover, Gear Pump	213.	Wire, Lock
35A.	Plug, Bushing	74.	Screw, Slideblock Cover	214.	Plunger, B. P. R. V.
35B.	Seal, O'Ring	75.	Cover, Slideblock End	215.	Spring, B. P. R. V.
35C.	Ring, Retaining	76.	Tubing, w/fittings	216.	Shim, B. P. R. V.
37.	Seal, O'ring	77.	Key, Pintle	217.	Shim, B. P. R. V.
38.	Cap, H. P. R. V.	78.	Gasket, Flange	218.	Cap, B. P. R. V.
38A.	Screw, Sock. Hd. Cap	79.	Flange, Pipe	218A.	Screw, Sock. Hd. Cap
39.	Gasket, H. P. R. V. Cap	80.	Cover, Pintle End	219.	Plug, Pipe
40.	Screw, H. P. R. V. Adj.	80A.	Screw, Sock. Hd. Cap	220.	Plug, Pipe
40A.	Nut, Adj. Screw Lock				

* Parts numbered 6 & 7, 34 & 35, 50 & 51 are furnished only as assemblies.

NOTE:

When ordering replacement parts, be sure to include pump serial no., data sheet (DS) no. and part no.

Specify type of hydraulic fluid for O'rings, packings and seals.

O'RING SIZES

Cross Section x I.D. x O.D. Duro + 5					
Pump Size					
Part No.	4, 8 & 12		20 & 35		60
	35B.				
37.	3/32 x 11/16 x 1-1/16	70	1/8 x 1-1/2 x 1-3/4	70	1/8 x 1-5/8 x 1-7/8 70