

# PINTLE CHECK SUCTION VALVE

USED ONLY ON PUMPS EQUIPPED WITH PINTLE CHECK VALVES.

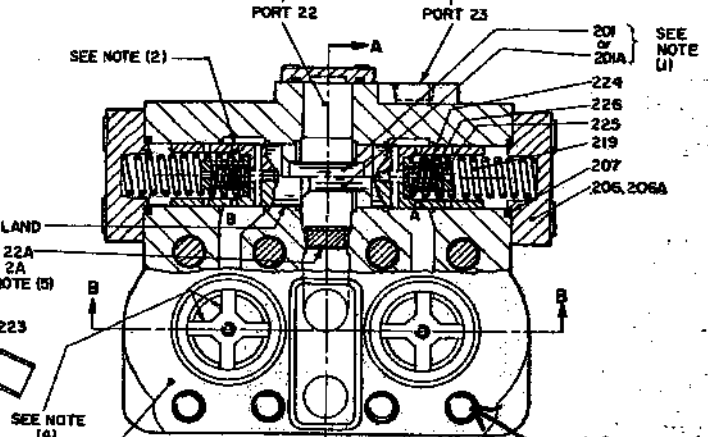

PRINTED IN U.S.A.

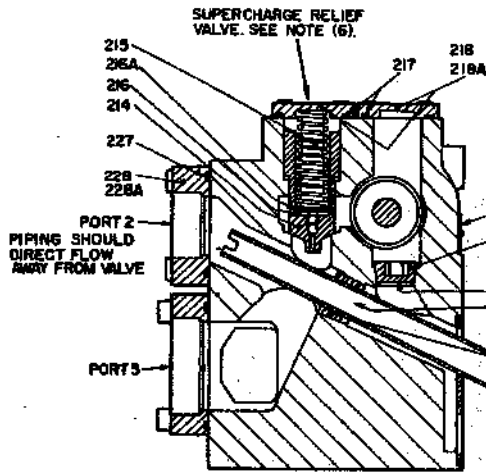
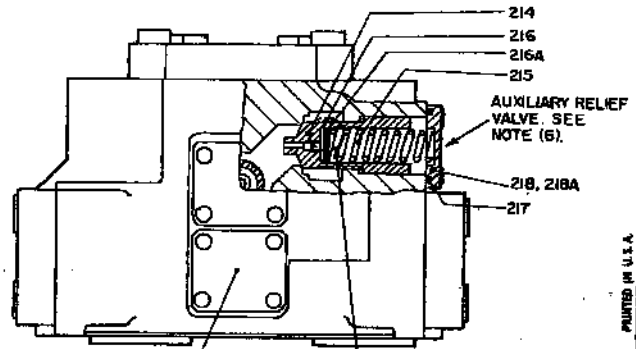

SECTION A-A

SECTION B-B

**IX. PARTS LIST**

PART NO.	DESCRIPTION	PART NO.	DESCRIPTION
200.	BODY, VALVE	216A.	SHIMS
200A.	SCREW, SOCK. HD. CAP	217.	O-RING, 3/16 x 2-5/8-70
201.	PLUNGER, STANDARD MAIN	218.	COVER
201A.	PLUNGER, LONG LAND MAIN	219.	SPRING, MAIN PLUNGER
202.	O-RING, 3/16 x 4-90	220.	SPRING, CHK. VALVE DISC
206.	CAP, PLUNGER END	221.	RETAINER, SEAL
206A.	SCREW, SOCK. HD. CAP	222.	O-RING, 1/8 x 4-5/8-70
207.	O-RING, 3/16 x 2-7/8-90	223.	DIRECTOR, FLOW
208.	GUIDE, CHECK VALVE DISC	224.	PLUNGER, PLUNGER CHECK VALVE
209.	DISC, SUCT. CHK. VALVE	225.	CASE, PLUNGER CHK VALVE
210.	SEAT, SUCT. CHK. VALVE	226.	SPRING, PLUNGER CHK. VALVE
212.	FLANGE, SUCTION PIPE	227.	O-RING, 3/16 x 3-3/4-70
212A.	SCREW, SOCK. HD. CAP	228.	FLANGE, R. V. EXHAUST
213.	O-RING, 3/16 x 4-1/2-70	229.	PLUG, PIPE
214.	PLUNGER, RELIEF VALVE	230.	PLATE, INSTRUCTION
215.	SPRING, RELIEF VALVE		
216.	WASHER, 3/16" PLAIN		

WHEN ORDERING PARTS, INCLUDE PUMP SERIAL NO., DS-NO., AND PART NO. SPECIFY TYPE OF HYDRAULIC FLUID USED. PARTS USED IN THIS ASSEMBLY ARE PER OILGEAR SPECIFICATIONS. USE OILGEAR SUPPLIED PARTS TO INSURE COMPATIBILITY WITH ASSEMBLY REQUIREMENTS.

**NOTES**

- (1) BEFORE REMOVING, MARK PLUNGER END & BODY SO PLUNGER WILL BE RETURNED TO SAME POSITION. IF PLUNGER BLOCKING SPACER (NOT SHOWN) IS IN BORE, NOTE WHICH END IT'S IN.
- (2) ASSEMBLE PLUNGER WITH THIS HOLE 90° FROM POSITION SHOWN.
- (3) IF GUIDE (208) WAS PRESSED OFF SEAT (210), PRESS BACK ON LEAVING AT LEAST .06" GAP HERE BEFORE ASSEMBLING VALVE TO PUMP.
- (4) RIBS OF GUIDE (208) MUST BE IN POSITION SHOWN.
- (5) ON SOME SYSTEMS, PORT 2A IS BLOCKED & PORT 22A OPEN.
- (6) DO NOT MIX AUXILIARY & SUPERCHARGE RELIEF VALVE SHIMS.

DR. D.P.	CH. SP.	506486C
TR.	APP. 1/77	

PARTS DRWG. PINTLE CHECK SUCTION VALVE

# CUTAWAY DIAGRAM PINTLE CHECK SUCTION VALVE



PUMP PORT 25 MUST CONNECT TO PINTLE END COVER PORT 25A. PUMP MUST BE EQUIPPED WITH PINTLE CHECK VALVES.

SEE PUMP BULLETIN 947000 FOR BALANCE OF DIAGRAM.

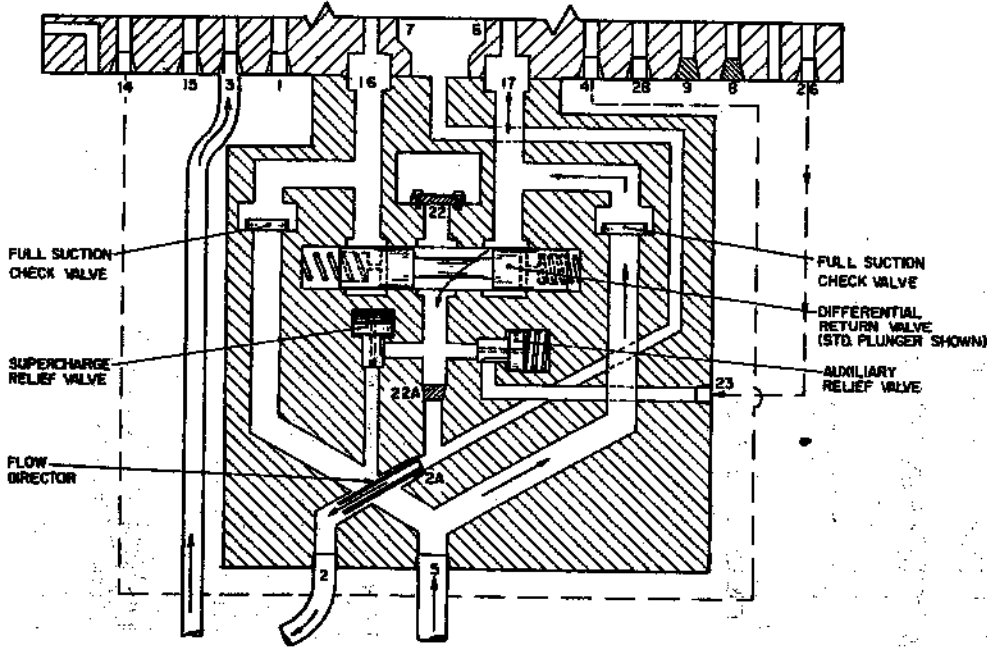

PRINTED IN U.S.A.

DR. D.L.P.	CR.	AM	506486C
DIAGRAM, PINTLE CHECK SUCTION VALVE			

REISSUED NOV. 1975

THE OILGEAR COMPANY  
MILWAUKEE, WISCONSIN, U.S.A. 53219

SHEET 2 OF 2

DS-947919C