



# INSTRUCTIONS

## OILGEAR TYPE "DN" TWO-WAY VARIABLE DELIVERY PUMPS

BULLETIN 947925

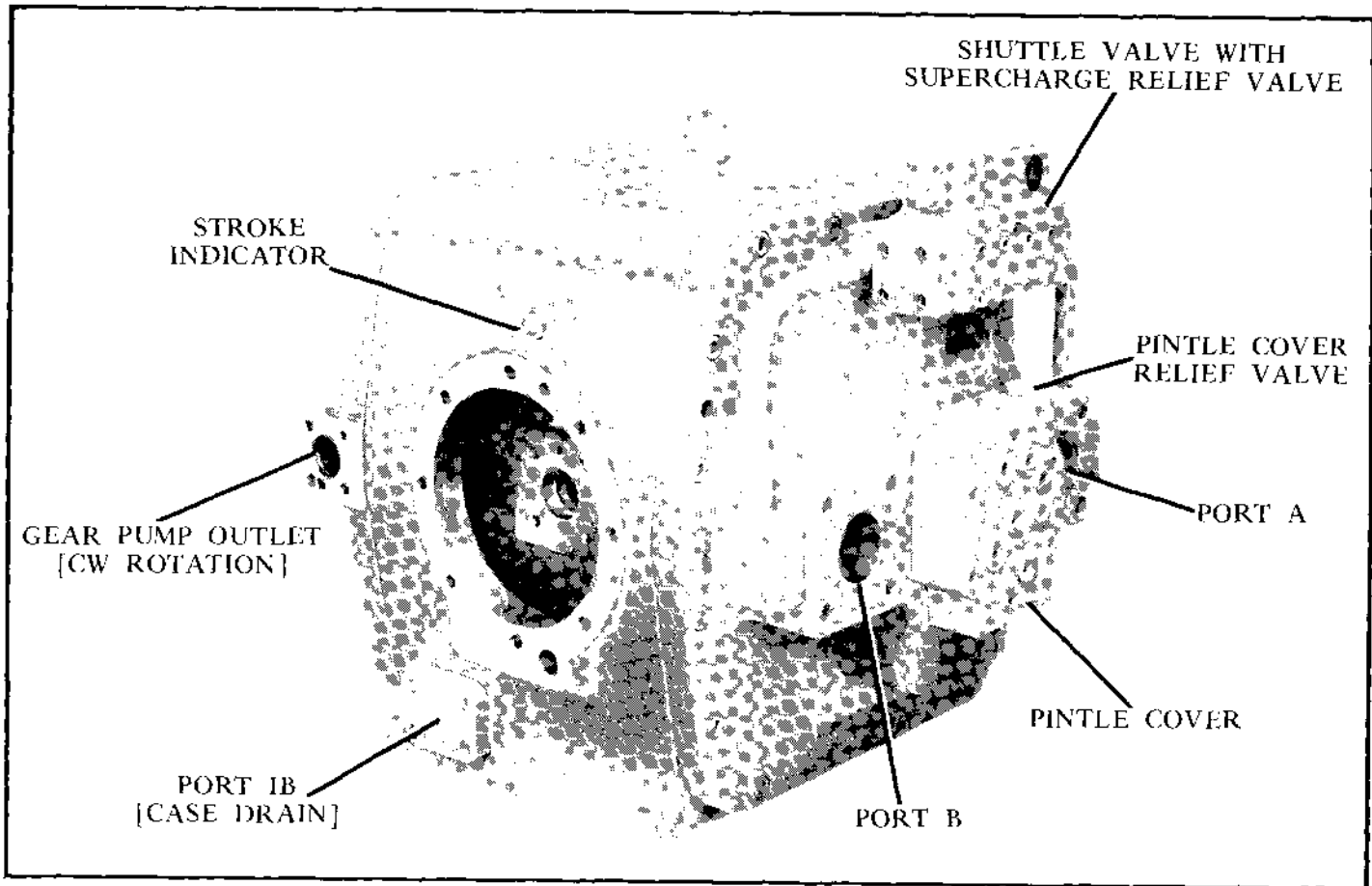

Figure 1. Type "DN" Pump w/gear Pump and Shuttle Valve With Supercharge Relief Valve. (55399R)

### REFERENCE BULLETINS

**Pump Controls**

"A"	Pneumatic . . . . .	947005
"H"	Hydraulic Servo . . . . .	947401
"M"	Electric Multi-Position . . . . .	947280
"P"	Pressure Unloading . . . . .	947501
"R"	Hydraulic Remote . . . . .	947601
"R-T"	HYTAC . . . . .	947610
"S"	Handwheel . . . . .	947101
"V-W & -H"	Electrohydraulic Servo w/Hydraulic Amplifier . . . . .	947770
"V-V & -N"	Electrohydraulic Servo . . . . .	947742

For pumps using dual controls (such as "DMP") refer to "M" and "P" control instructions.

Opposing Operators . . . . .	DS-947015
"C" Acceleration-Deceleration . . . . .	947918
Filtration Recommendations . . . . .	90007
Gear Pump Full Flow Filter . . . . .	DS-89907
Fluid Recommendations . . . . .	90000
Piping Information . . . . .	90011
Contamination Evaluation Guide . . . . .	90004

**TO THE USER.....**

These instructions will assist you in the installation, operation and maintenance of "DN" pumps and optional components. Some units have been modified from those described in this bulletin and other changes may be made without notice.

**THE Oilgear COMPANY**

2300 So 51st St. Milwaukee, WI 53219

Issued: March, 1983

**BULLETIN 947925**

# I. PREPARATION AND INSTALLATION

## A. MOUNTING

1. PUMPS WITHOUT RESERVOIR. Pumps can be shipped with or without suction and discharge (drain) tubes installed. In either case remove all pipe tap protectors, but not pipe plugs.

**IMPORTANT:** Case drain port 1 must be located above the reservoir level in order to discharge (drain) fluid. A tube is not required for case drain. Port numbers are stamped on pump case and optional components. Connect suction and discharge tubes to their respective ports. Proper size tubes must be used on all ports. Size recommendations can be obtained from an Oilgear Application Engineer. Also see "Piping Information" bulletin. Clean external surfaces of pump thoroughly and secure pump and gasket to mounting surface.

2. PUMPS WITH RESERVOIRS. Mount reservoir on level foundation at least six inches above floor level to aid in draining of reservoir fluid.

## B. PIPING AND FITTINGS.

See Oilgear "Piping Information" bulletin before connecting to system.

### CAUTION

If pump is not equipped with Oilgear suction check and high pressure relief valves (HPRV), the pump and system must be protected against overloads by relief valves. Several HPRV options are available from Oilgear. All connections should be tight to prevent drawing air into the system and fluid leakage.

### CAUTION

The following applies to pumps equipped with the optional Shuttle Valve w/Supercharge Relief Valve: When the pressure difference between the A & B ports is approximately 17 psi or less in the radial piston pump circuit, the shuttle valve plunger will shift to the blocked center position, therefore a relief valve **MUST** be provided in a line entering the pintle check circuit, such as ports 25A, 25E or 25J.

## C. POWER

Power is required in proportion to needed volume and pressure. Standard low starting torque motors are suitable for most applications. Motor size recommendations for specific applications can be obtained from The Oilgear Company.

## D. DRIVE

See rotation direction plate on pump housing. Drive the pump driveshaft in direction of arrow on plate. **DO NOT ROTATE SHAFT IN OPPOSITE DIRECTION.** Use direct drive. Provide an easy slip fit for coupling, then fasten securely. **DO NOT DRIVE COUPLING ONTO DRIVE-SHAFT.**

## E. FLUID AND FILLING RECOMMENDATIONS

See "Fluid Recommendations" bulletin available from The Oilgear Company or refer to instruction plate on pump, reservoir or machine. Pump all fluid into reservoir through a clean filter of the proper Beta 10 ratio. Fill reservoir up to, but not above high level on sight gage. Using a spanner wrench, turn driveshaft a few times to be sure shaft turns freely. With pump control at "neutral" or pump under "no load" condition, turn drive unit on and off several times before pump reaches full speed. The system can be filled by operating the pump and control. If fluid level becomes low, stop pump, add fluid and start again. On differential systems, fluid must not be above "high" level with ram retracted or below "low" level with ram extended. To bleed air from system, open petcocks at the highest points in system. When a solid stream of fluid appears, close petcocks.

## F. FLUID FILTER

See "Fluid Recommendations" bulletin. Oilgear recommends using a filter between the optional gear pump and the gear pump relief valve as shown on circuit diagram of pump. See appropriate reference material for information on filter. Replace filter elements when condition indicator reaches "change" area, at normal fluid temperature. Drain and thoroughly clean filter case. Replace element with one of same Beta 10 ratio, normally of 4. The Beta 10 ratio of 4 means that of every 4 pieces of contamination that enter the filter, only 1 will pass through the filter. An additional filter is provided with some controls. It is important to replace this element when dirty.

## G. AIR BREATHER

An air breather is mounted on top of fluid reservoir on most installations. It is important for breather to be of adequate size to allow air flow in and out of reservoir as fluid level rises and falls.

To clean breather, remove breather cover, wash screen in non-flammable solvent, refill case to level mark, then install dry screen and cover.

## H. FLUID COOLING

Auxiliary cooling of fluid may be necessary if pump is operated continuously at rated pressure or frequently at peak load. Fluid temperature should not exceed the limits specified in the Oilgear "Fluid Recommendations" bulletin.

## II. CONSTRUCTION

See Figure 13. Basic pump components are a pintle (5), cylinder and bushing assembly (6 & 7) with closely fitted radial rolling pistons (8) thrust rings (18) rotor (16), rotor cover (65), slideblock (82), driveshaft (1) and case (56). The cylinder and tapered bushing assembly, lined with bearing material, rotates on a fluid film around the stationary, tapered pintle which was pressed into the case. The driveshaft (1) rotates on two bearings (11 & 12) and is connected directly to the cylinder through a splined, floating coupling (19). Automatic running-clearance control of the steep, tapered cylinder bushing and pintle is provided by flat springs (97), yoke (98), coupling flange with piston ring (19 & 19A), orifice (95) and relief valve (103).

The pintle cover (80) contains passages of the pintle check circuit, which provide for lubrication of the cylinder-pintle assembly. The circuit can receive fluid from port 8 of the optional gear pump relief valve or from an external source.

### CAUTION

In either case, a relief valve must be located in the line that supplies the pintle check circuit.

#### A. OPTIONAL GEAR PUMP

See Figure 14. An optional constant delivery gear pump (22 & 23), built into the front housing (72C), can supercharge the main system, supply hydraulic controls and auxiliary equipment as well as provide flow for continuous filtering and cooling of system fluid.

#### B. OPTIONAL SUCTION CHECK VALVE W/HIGH PRESSURE RELIEF VALVE (HPRV).

See Figure 15. The optional suction check valve (209) can be mounted to the A and/or B ports and consists of a suction check valve (209) enclosed in body (203). The high pressure relief valve (450) is mounted to the suction check body.

#### C. OPTIONAL ONE-WAY SUCTION CHECK W/BACK PRESSURE RELIEF VALVE (BPRV).

See Figures 15 & 16. The optional one-way suction valve with back pressure relief valve should be mounted to the suction port only. Both ports A & B will accept the valve, which consists of a suction check with an adjustable BPRV (235) mounted to the suction check body.

#### D. OPTIONAL SHUTTLE VALVE W/SUPERCHARGE RELIEF VALVE (SCRV)

See Figure 17. The optional shuttle valve is flange mounted to the rear pump case and connected to ports A & B using special manifolding and piping. The valve body contains a spring centered plunger (264), two one-way checks (265) and a supercharge relief valve.

#### E. OPTIONAL GEAR PUMP RELIEF VALVE (GPRV) AND OPTIONAL FILTER MANIFOLD

The gear pump relief valve is mounted to the front housing flange and consists of a dashpot type relief valve (279) enclosed in a body (277).

An optional filter manifold (290) can be installed between the GPRV and the pump flange. The manifold provides passages for gear pump fluid to the bias control, to and from the filter, then back to the GPRV.

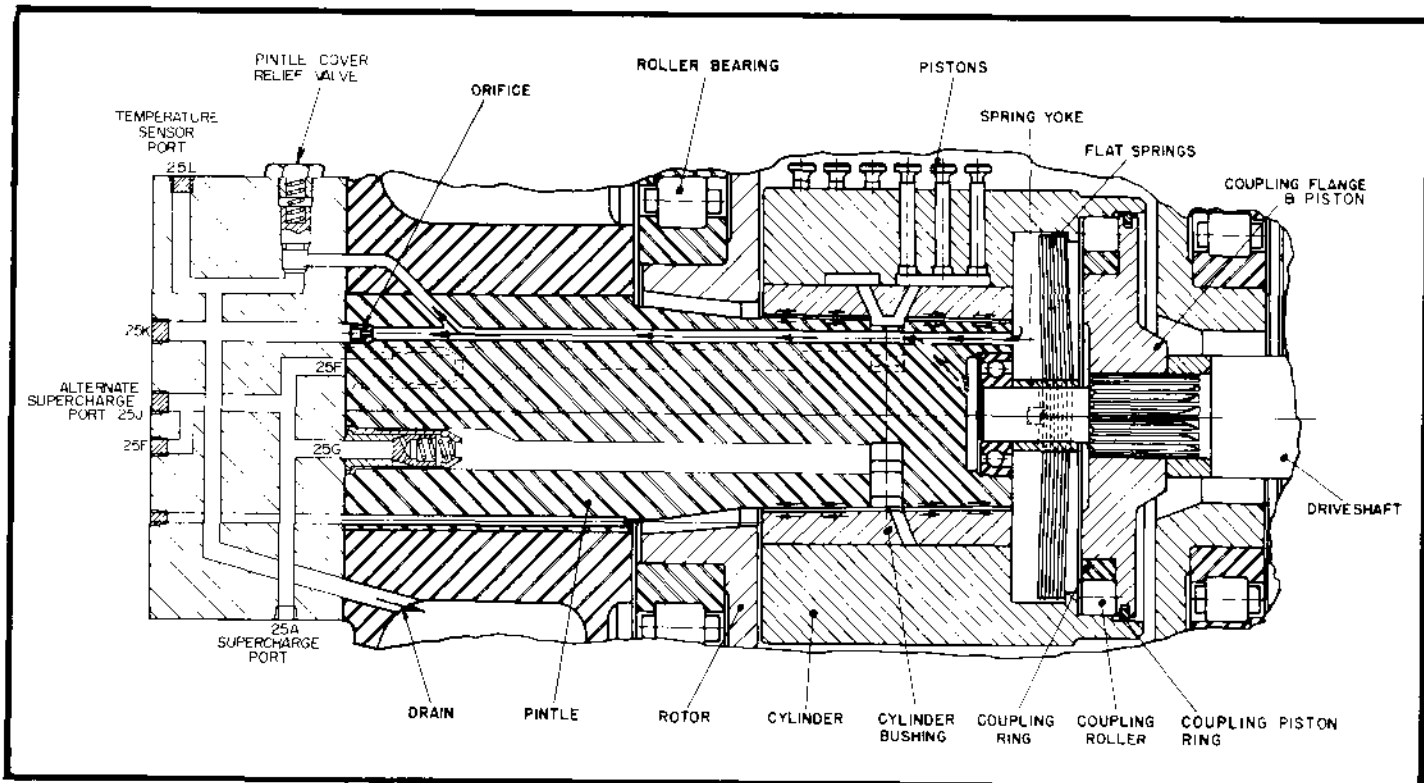

Figure 2. Cylinder Clearance Control. (508644)

### III. PRINCIPLE OF OPERATION

#### A. RADIAL PISTON PUMP

See Figure 3. The cylinder and piston assembly rotates around the pintle on a thin lubricating film. Centrifugal force and system back pressure force pistons against thrust rings, causing the rotor and rotor cover assembly to rotate with cylinder assembly within the moveable slideblock. Controls on either or both sides of case move the slideblock, with rotor and rotor cover assembly, to the left or right of the cylinder-pintle centerline. Fluid is delivered to and from the pistons via passages in the case, pintle and cylinder assembly.

As the control mechanism moves, with the slideblock-rotor assembly moved to the left, the pistons move outward during the lower half revolution receiving one or any combination of: return fluid from port B, supercharge fluid from the gear pump or direct suction of fluid, to fill the cylinder piston bores. During the upper half revolution of the cylinder, the pistons move inward, delivering fluid under pressure, through the upper pintle passage to port A.

The pump is in the "NEUTRAL" position when the vertical centerlines of the cylinder and rotor coincide. The pistons do not move in or out, therefore, fluid is not delivered out of either port.

Moving the slideblock rotor assembly to the right, past neutral, reverses flow from port A to Port B.

This description covers two-way flow pumps. Optional components (shown) can be added, depending on the application. The slideblock on one-way pumps moves from neutral to a position normally on the left, when facing driveshaft.

#### NOTE !

See individual instruction bulletins for operation principle of particular controls.

#### B. CYLINDER CLEARANCE CONTROL

See Figure 2. The cylinder clearance control automatically moves the cylinder axially on the tapered pintle to maintain optimum running clearance at all pressures. Fluid slips past the running clearance on the small end of cylinder and pintle, then flows into the flat spring chamber of the coupling flange and piston ring as well as the pintle orifice. When pump pressure increases, fluid escaping through the running clearance gradually increases, building up chamber pressure which moves the cylinder farther onto the tapered pintle, reducing running clearance.

Pressure in the flat spring chamber is limited by the pintle cover relief valve.

#### C. OPTIONAL GEAR PUMP

See Figure 3. Consisting primarily of a drive gear and a driven gear, the gear pump is driven by the main pump driveshaft. Rotation of the gears creates a partial vacuum at the gear pump inlet, port 3, drawing fluid into the gear pump circuit. Sufficient pressure is created to operate slideblock controls. Excess fluid partially supercharges the radial piston pump. Gear pump fluid should always be filtered according to "Filtration Recommendations" bulletin. The optional filter manifold must be used to provide filter inlet and return ports.

#### D. OPTIONAL SUCTION CHECK W/HPRV

See Figure 3. The suction check manifold allows fluid to be drawn to the main pump and to retain supercharge fluid while blocking flow back into the reservoir. The valve disc (209) is held in the closed (sealed or blocked) position by a relatively weak spring. The high pressure relief valve functions only when mounted on the pressure (outlet) side of the pump, therefore, it is always used in conjunction with the suction check on two-way pumps. Fluid flowing thru the HPRV plunger (485) slots and into the pilot relief valve is blocked by the Poppet (468). When system pressure exceeds pilot valve setting the poppet opens, allowing plunger to lift and control the discharge of fluid to the reservoir. When system pressure becomes lower than HPRV setting, pilot poppet and plunger close in sequence.

#### E. OPTIONAL ONE-WAY SUCTION CHECK W/BPRV

See Figure 3. For operating principles of suction check, see previous example (Suction Check w/HPRV). Back pressure forces the plunger (238) open at low pressure, allowing excess fluid to escape to reservoir. As back pressure decreases, the return spring forces the plunger closed.

#### F. OPTIONAL SHUTTLE VALVE W/SCRV

See Figure 3. Gear pump flow, in excess of what is needed by the pintle check circuit can result at various times. Some or all of the excess fluid may be used to aid in supercharging the piston pump. If the fluid is not used in the pintle check circuit or to supercharge the piston pump, it is directed to the shuttle valve SCR.V where it will discharge over the SCR.V at a relatively low pressure (See Specifications). However, pressure at the "DN" pump outlet port must be approximately 17 psi greater than pressure at the pump inlet port in order for the shuttle valve plunger to shift and expose excess fluid to the SCR.V. If the piston pump is at neutral, with less than valve plunger, another source of relief is needed. A relief valve must be provided in any line entering the pintle check circuit. An orifice in each spring chamber provides for a smooth, cushioned shifting of the shuttle valve plunger.

#### G. OPTIONAL GEAR PUMP RELIEF VALVE

See Figure 3. The gear pump relief valve is of the dashpot type. Gear pump pressure works against the bottom differential area of the plunger (279), forcing it open, then sending excess fluid to reservoir or another circuit, through port 8. As pressure decreases, the plunger will close, blocking flow out of port 8.

**IMPORTANT**

SYSTEMS WHICH UTILIZE THE OPTIONAL SHUTTLE VALVE W/ SUPERCHARGE RELIEF VALVE (S.C.R.V.) AND APPLY FLUID TO THE PINTLE CHECK CIRCUIT (PORTS 25A, E, J) FROM AN EXTERNAL SOURCE MUST HAVE A SEPARATE RELIEF VALVE IN THAT CIRCUIT.

THE S.C.R.V. WILL NOT PROVIDE RELIEF WHEN THE PUMP IS AT, OR VERY NEAR, NEUTRAL, DUE TO THE BLOCKED CENTER POSITION OF THE SHUTTLE VALVE PLUNGER. THE PLUNGER WILL REMAIN CENTERED UNTIL THERE IS A DIFFERENCE OF 17 PSI [1.17 BAR] BETWEEN 'A' AND 'B' PORTS.

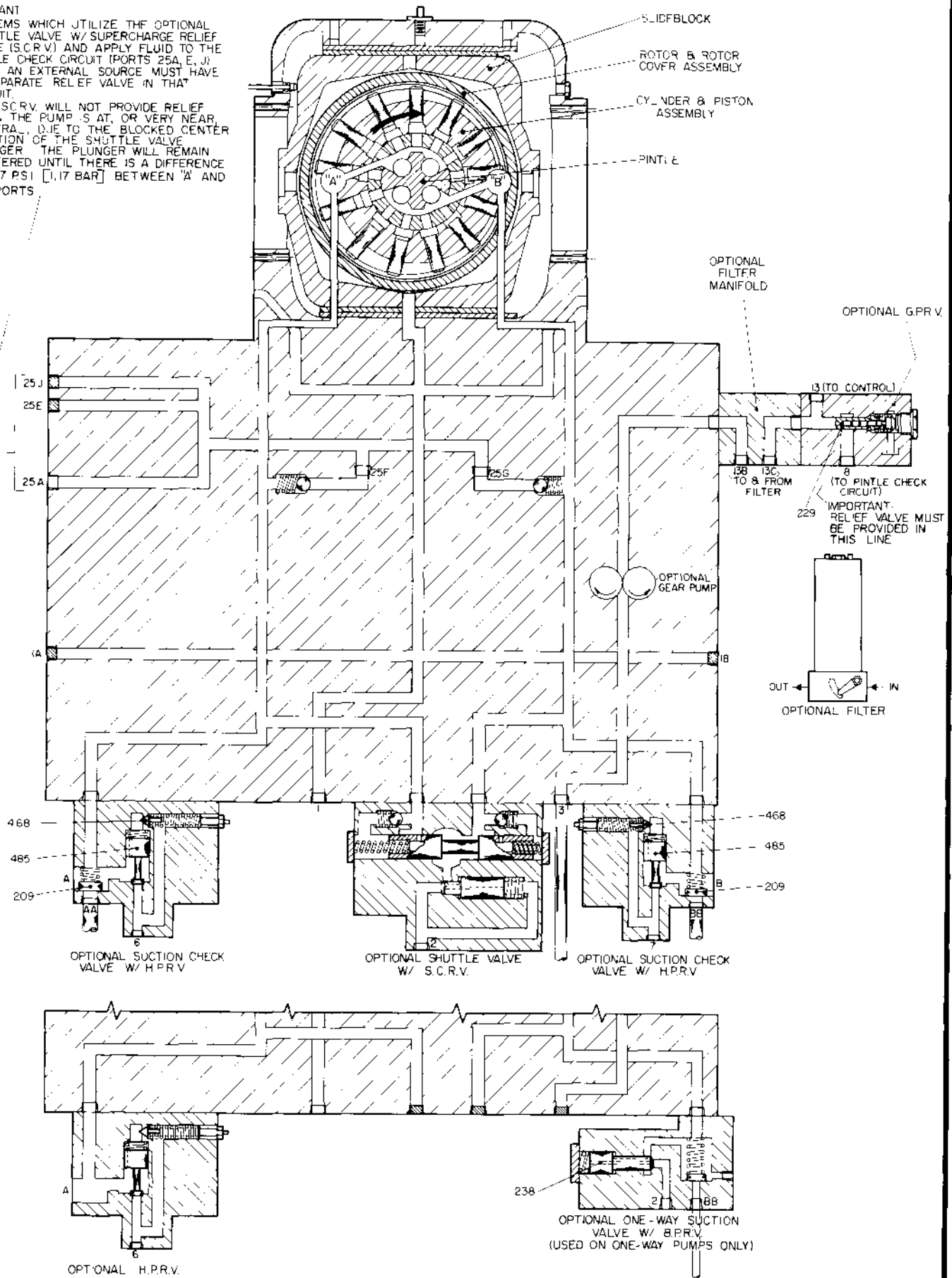

Figure 2. Cutaway Circuit of DN Pump, without Control. (508644)

## IV. SPECIFICATIONS

### A. RADIAL PISTON UNIT

- a. Maximum Eccentricity .675" (17.145 mm).
  - b. Vertical clearance between slideblock and liners - .010" - .015" (0.254 - 0.381 mm).
- NOTE: Clearance should never be less than .010" (0.254 mm).
- c. Slideblock movement needed to raise 1000 psi (69 bar) .035" - .047" (0.305 - 0.457 mm).
  - d. Slideblock End Play - .012" - .018" (0.305 - 0.458 mm).  
See previous note regarding clearances.
  - e. Rotor End Play within Slideblock .030" - .040" (0.762 - 1.016 mm).
  - f. Cylinder should begin to get tight when pintle projects .089" - .151" (2.261 - 3.836 mm).
  - g. Force to press pintle out of case - Approximately 250 tons.
  - h. Force to press pintle into case - Approximately 100 tons.
  - j. Cylinder off-of-tight position-- .050" (1.27 mm)
  - k. Maximum normal speed -- 1200 rpm.

### B. GEAR PUMP AND GPRV

- a. Volume at 215 psi and 900 rpm-- 7,030 cubic inches per minute (30 gal.) or 8,790 cubic inches (40 gal.) @ 1200 rpm.
- b. Gear pump relief valve setting when using:  
Control Types  
A, H, M, R, V-U and V-W -- 215 psi (14.83 bar)  
Control Types  
S & P-----85 psi (5.86 bar)

### C. HIGH PRESSURE RELIEF VALVE

#### PUMPS FOR GENERAL STRAIGHT-LINE APPLICATIONS.

- a. Continuous service ratings are:  
3000 psi (207 bar) -- DN 23030  
3500 psi (241 bar) . DN 20035
- b. Relief valve setting while blowing ½ volume:  
3250 psi (224 bar) - DN 23030  
4000 psi (276 bar) - DN 20035

RELIEF VALVES ARE OFTEN SET FOR LOWER PRESSURES TO LIMIT OVERLOAD PEAKS.

c. Adjustable "Cracking" pressure of 500 - 3000 psi (34.5 - 207 bar) on Models DN 23030.

Adjustable "Cracking" pressure of 500 - 400 psi (34.5 - 276 bar) on models DN - 20035.

## V. MALFUNCTIONS AND CAUSES

### A. UNRESPONSIVE OR SLUGGISH CONTROL

1. See appropriate control instruction bulletin.
2. Mis-aligned control.
3. Worn slideblock liners causing slideblock to bind.
4. Wrong eyebolt with longer threaded area may touch slideblock, restricting or preventing slideblock movement.

### B. INSUFFICIENT PUMPED VOLUME

1. Worn radial piston unit.
2. Suction valve disc not opening completely.
3. Obstruction in suction passages of case or pintle.
4. Cylinder bushing turning inside cylinder.
5. Faulty high pressure relief valve, i.e. plunger sticking open, worn or dirty valve seat, "cracking" pressure adjustment set too low.
6. Slideblock prevented from going on full stroke due to worn or dirty slideblock liners or extra long eyebolt. Observe stroke indicator.
7. Faulty control (see appropriate control instruction bulletin).
8. Faulty gear pump may not be supplying enough supercharge fluid or operating pressure for controls.
9. Faulty gear pump relief valve, i.e. plunger sticking open, dirty or worn seat.
10. Insufficient drive motor speed.
11. Shuttle valve plunger not shifting.

### C. IRREGULAR OR UNSTEADY OPERATION

1. Low fluid level in reservoir.
2. Air is entering system through loose connections or damaged gaskets.
3. Insufficient back pressure due to BPRV plunger not seating properly.
4. Insufficient gear pump control pressure or supercharge volume.
5. Sticking pistons or worn radial piston pump.
6. Faulty components supplied by radial piston pump, i.e. hydraulic motor, cylinder, etc.
7. Shuttle valve plunger sticking.

#### D. LOSS OF PRESSURE

1. Radial piston pump cannot create required pressure due to excessive wear.
2. Faulty HPRV, i.e. plunger sticking open, dirty or worn seat.
3. Faulty components operated by radial piston pump.

#### E. EXCESSIVE OR HIGH PEAK PRESSURE

1. HPRV plunger stuck to seat, plunger orifice clogged or adjuster knob turned in solid.
2. HPRV "cracking" pressure set too high.

#### F. EXCESSIVE NOISE

1. Worn, pitted bearings or thrust rings.
2. Incorrect clearance of rotor or slideblock within the pump
3. Excessive wear throughout pump.
4. Air entering system past large end of pintle, suction valve gasket or loose connections.
5. Starting or stopping pump under pressure.
6. Fluid too cold or viscosity too high.
7. Lack of back pressure, possibly due to insufficient gear pump pressure or flow.

#### G. EXCESSIVE HEAT

1. Operating pump above rated or peak pressure.
2. Sticking radial pistons or worn radial piston unit.
3. HPRV leaking.
4. Insufficient cylinder running clearance.
5. Low fluid level in reservoir.
6. Insufficient supercharge fluid.

## VI. TESTING AND ADJUSTING



NEVER ATTEMPT TO INSTALL OR REMOVE ANY COMPONENTS WHILE PUMP IS RUNNING. ALWAYS STOP PUMP AND RELEASE PRESSURE FROM SYSTEM BEFORE SERVICING OR TESTING. PERSONAL INJURY COULD RESULT IF SYSTEM PRESSURE IS NOT RELEASED BEFORE SERVICING OR TESTING.

Standard pilot head is shown. See DS-982400 for other pilot head configurations.

See Figure 15. Check high pressure relief valve setting at pressure (outlet) port using a 6,000 psi (414 bar) gage or install a gage in the port marked "13 VENT" on the top of HPRV pilot head or in the tapped hole in the side of the pressure port flange.

See Figure 4. Start pump at neutral, adjust control for approximately 1/2 volume, then check setting on indicator stem. Stall the ram or output shaft of driven component to raise pressure, then notice gage reading, which will indicate HPRV setting. See Figure 15. While fluid is warm make any necessary relief valve adjustments by loosening locknut (455) and turning adjusting screw (463) inward to increase or outward to decrease "cracking" pressure.

### CAUTION

Discharge fluids over relief valve only long enough to obtain a pressure reading. Damage to system components could result if fluids are discharged over relief valve for long periods of time.

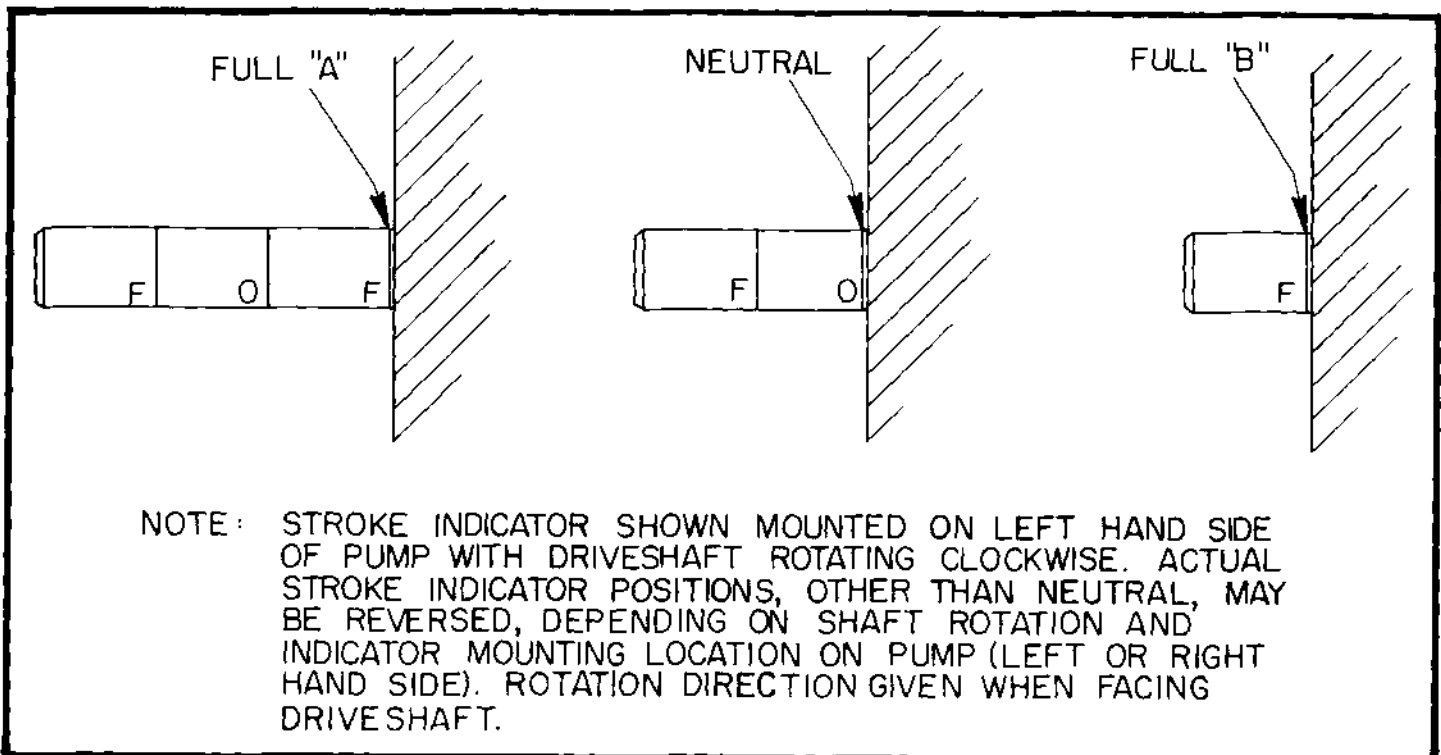

Figure 4. Stroke Indicator Positions. (508644)

DO NOT ADJUST FOR PRESSURES HIGHER THAN THOSE LISTED IN "IV SPECIFICATIONS"

and tap a 1/4" NPT hole in center of flange to accommodate a pressure gage and pipe plug.

#### B. GEAR PUMP RELIEF VALVE (GPRV)

See Figure 18. To check pressure setting, install a 500 psi (35 bar) gage into port at top of GPRV using a No. 8 SAE x 1/4" NPT bushing to accommodate the gage. See "IV" SPECIFICATIONS. Settings may be slightly higher when fluid is cold. DO NOT take a reading until fluid is warm.

To make adjustment, remove cap (285) and O-ring (284). Add shims (282) to increase pressure setting or remove shims to decrease setting. Each shim will change setting about 5 psi.

### CAUTION

Don't shim for pressures higher than those listed in specifications section because the spring will be compressed solid, resulting in a unsafe condition and damage to the system. If adding or removing shims fails to change GPRV setting, disassemble GPRV, inspect, clean, reassemble and check pressure setting.

#### C. GEAR PUMP

See "Gear Pump Relief Valve" section to determine if adequate gear pump pressure can be raised.

To check gear pump volume, install a pipe tee into port 13 of the gear pump relief valve. Install a 500 psi (35 bar) gage onto one leg of tee and a needle valve into the other leg. Place a container of a known volume (5 gal. pail, etc.) below needle valve, start pump at neutral and open needle valve until pressure gage reads proper pressure (See "IV" SPECIFICATIONS). Measure volume discharged at that pressure. Discharged volume should be about 30 gpm @ 900 rpm or 40 gpm @ 1200 rpm. Volumes less than listed will result in slower control shifting speeds.

#### D. RADIAL PISTON UNIT

### WARNING

A HIGH PRESSURE RELIEF VALVE MUST BE PRESENT SOMEWHERE BETWEEN THE RADIAL PISTON PUMP AND THE POINT AT WHICH THE HIGH PRESSURE LINES ARE BLOCKED.

See Figure 13. Remove 1/4" pipe plug from flange on the outside of the port (A or B) to be tested.

Earlier models without shuttle valve may not have a 1/4" NPT pipe plug installed in either flange. In this case, shut off drive motor, release pressure from system, remove flange, then drill

Install a 6000 psi (414 bar) pressure gage into tapped hole in flange, then block all high pressure lines of circuit. Set control at "neutral" and mount dial indicator on pump to measure movement of slideblock indicator (88). Set dial indicator for zero and start drive motor. Slowly adjust control for delivery at port with pressure gage, until gage reads 1000 psi (69 bar). Notice dial indicator reading, then release pressure and shut off drive motor. Total slideblock movement needed to raise that pressure is listed in "IV" SPECIFICATIONS. Wear is indicated if slideblock movement exceeds specification range.

#### ALTERNATE METHOD

Remove eyebolt (90) from case and observe. If fluid runs out of this hole, while pump is running under pressure, leakage is excessive and repair is necessary.

### WARNING

DO NOT POSITION YOUR FACE DIRECTLY OVER THE EYEBOLT HOLE. PERSONAL INJURY COULD RESULT FROM FLUID SPOUTING FROM THIS HOLE.

#### E. SUCTION CHECK VALVE W/BACK PRESSURE RELIEF VALVE (BPRV)

See Figure 16. Check back pressure relief valve setting as follows: Remove 1/2" NPT pipe plug located on the side of the BPRV body and install a 1/2" NPT x 1/4" NPT bushing in that hole. Install a 300 psi (21 bar) gage into bushing, then start pump at neutral. Gage should read back pressure, which should be approximately 50 psi while discharging 30 gpm back to reservoir. If back pressure is considerably higher or lower, disassemble and clean valve. Reassemble and test.

Check suction valve disc (209 in Fig. 15) movement by pushing up, against spring. Disc should move from seat with some resistance, but also without sticking to seat. Check seat and remove foreign particles to insure even seating of the disc.

#### F. SHUTTLE VALVE W/SUPERCHARGE RELIEF VALVE

See Figure 17. Check SCR operation as follows: Remove a 1/2" NPT pipe plug from front of shuttle valve body, install a 1/2" NPT x 1/4" NPT bushing into hole and a 500 psi (35 bar) gage into bushing. Start pump at neutral, set pump on stroke, and observe gage reading, which will be SCR setting of approximately 50 psi. If pressure reading is considerably lower or higher, disassemble and clean, then reassemble and test.

Check shuttle plunger movement as follows: Remove two 1/4" NPT pipe plungers from flanges and install a 6000 psi (414 bar)



gage into each hole. Start pump at neutral, set pump on stroke approximately 5% at port A and notice gage readings. "A" port gage should read the lower of either system pressure or HPRV setting, while "B" port gage should read SCR V setting. **IMPORTANT:** In order to get an accurate SCR V reading, the "DN" pump must deliver a volume which is LESS than the supercharge volume. Stroke pump to neutral, then to deliver out of B port. Notice gage readings. "B" port gage will read the lower of either system pressure or HPRV setting while "A" port gage should read SCR V setting. Both tests must prove positive. If either or both tests are negative, disassemble valve, clean and reassemble. Repeat tests.

#### G. PINTLE COVER RELIEF VALVE

See Figure 19. Check pintle cover relief valve operation as follows: Remove Plug 2 from pintle cover. Start pump and set at half stroke. Pintle cover relief valve should open (crack) at the same time as HPRV opens. Wearing safety glasses, observe flow through Plug 2 hole. If pintle relief valve opens without pressure in high pressure line, shut pump off, disassemble relief valve and clean thoroughly. Reassemble and test. Do not install additional shims. Contact Oilgear Service Department for instructions if condition persists.

Check supercharge pressure as follows: Pump can be supercharged through ports 25A or 25J. Remove plug from port which is not supercharged. Install No. 20 SAE x 1/4" NPT bushing into port, then install a 1000 psi (69 bar) gage into bushing. Start pump and set at approximately 5% stroke. Gage will read supercharge pressure.

## VII. DISASSEMBLY

Only certain parts may need to be replaced, therefore it may not be necessary to completely disassemble pump. Refer to the appropriate sub-section for instructions.

#### A. PUMP MOUNTING

Disconnect pump from circuit and drive motor. Remove A and B flanges. Tag all gaskets, O-rings and shims during disassembly to aid in assembly.

#### B. PINTLE COVER

See Figure 19. Disconnect supercharge connection and pintle check circuit piping. Remove six socket head cap screws (80A) and four No. 16 SAE plugs (104). Remove four socket head cap screws (80B) which are located below plugs 104. Pintle cover (80) will be free of rear case. Remove cap (99), gasket (102), shim (101), washer (114), spring (100) and plunger (103). A 1 1/2 - UNC bolt or puller can be installed inside check valve body. Remove check valves (107) as an assembly.

#### C. OPTIONAL SUCTION CHECK VALVE MANIFOLD

See Figure 15. Remove four socket head cap screws (200A) then flanges (200) with O-ring (201) and valve body (203) will be free of rear cover (123). Remove four socket head cap screws (204A) and flange (204) and O-ring (205) will be free of body. Pull check valve assembly (208, 209, 210, 220) from body.

#### D. OPTIONAL HIGH PRESSURE RELIEF VALVE

See Figure 1. Standard pilot head is shown. See DS-982400 for other configurations. Disconnect all piping leading to operator head (453) and relief valve body (450). Remove four socket head cap screws (450A), then relief valve body will be free of suction valve body (203) or pump port manifold, whichever it is mounted to. Remove four socket head cap screws (452) and operator head will be free of relief valve body. Parts information for operator heads other than type shown can be found in bulletin DS-982400. Remove O-ring (480 & 481), spring (484) and plunger (485). Do not remove seat (491) unless damage is noticed. If seat replacement is necessary, remove four socket head cap screws (487), flange (488), O-ring (489) and spacer (490). Place body onto arbor press and press seat from body.

#### E. OPTIONAL BACK PRESSURE RELIEF VALVE MODULE

See Figure 16. Remove four socket head cap screws (225), cover (226), gasket (227), spring (229), spacer (228) and plunger (238) with washers (230). Remove four socket head cap screws (233) then flange (232) will be free of manifold. O-ring (234) is accessible.

#### F. OPTIONAL SHUTTLE VALVE W/SUPERCHARGE RELIEF VALVE

See Figure 17. Disconnect all piping leading to shuttle valve body (250). Remove eight socket head cap screws (250A) and body will be free of pump.

#### SUPERCHARGE RELIEF VALVE

Remove four socket head cap screws (251), cover (252) and gasket (253). Remove spring (254), spacer (255) and plunger (256) with shims (257).

#### SHUTTLE VALVE ASSEMBLY

Remove four socket head cap screws (260A) from each flange (260) and flange will be free of valve body. Remove O-ring retainers (262), O-rings (261) and springs (263). Remove plunger (264) from either end of body. Remove O-ring (266), check valves (265) and O-rings (267).

## G. OPTIONAL GEAR PUMP RELIEF VALVE MODULE

See Figure 18. Remove cap (285), O-ring (284), spacer (283), shim(s) (282), dashpot (281), spring (280) and plunger (279). Remove SAE plugs only if leakage at the plug has occurred. Remove four socket head cap screws (278) and manifold will be free of pump. The filter manifold (290), when used, is mounted between the GPRV manifold and pump. O-rings (288 & 289) provide for sealing between the filter manifold and GPRV manifold.

## H. FRONT COVER

See Figure 13. Set pump on rear cover end and block securely in place. Remove front cover screws (72A). Fasten a lathe dog to driveshaft (1). Install ½" - 13 hook bolt into seal gland mounting holes. Using a suitable crane, carefully raise entire housing (72) from pump case. Use caution to prevent damaging shaft, bearing and coupling flange. Remove cover gasket (29).

## I. OPTIONAL GEAR PUMP HOUSING

See Figure 14. Remove drive key (125) and cover screws (72B). Install three ½ - 13 hook bolts into tapped holes in outer rim of housing (72C), then lift from pump using a suitable crane. Remove driveshaft as described in "Shaft Removal" section. Turn housing over to make gear pump accessible for disassembly. Remove locking wire (106), cover screws (69) and gaskets (70). Lift cover (73) and gears (22 & 23) from housing.

## J. SHAFT REMOVAL

See Figure 13. Remove driveshaft (1) only if inspection of shaft seal (27) and/or front bearing (11) is necessary. If necessary, proceed by removing shaft seal gland screws (71A). Carefully file away any burrs on keyway, then apply a piece of tap to keyway to protect shaft seal during removal. Slide gland (71) and seal from shaft. Lift shaft, with bearings from housing. Shims (15) must be reassembled in the exact order they were disassembled, therefore keep shims organized (in original positions) to ease assembly.

## K. RADIAL PISTON UNITS

See Figure 13. Lift spacer ring (68) and shims (67) from slideblock cover (75). Remove locking wire (106) and cover screws (74). Install two ½ - 13 NC hook bolts into tapped holes in cover and remove cover using a suitable crane. Press outer race of rotor cover bearing (10) from slideblock cover only if bearing is being replaced. Remove locking wire and rotor cover screws (66). Install three 5/8 - 11 x 2 ½" bolts into tapped holes in outer rim of rotor cover (65). Jack cover from rotor (16) and pump. If bearing (10) is to be replaced, jack inner

race from cover by installing three 5/8 - 11 x 3 ½" bolts into tapped holes in hub of cover (65). Lift out coupling flange (19), piston ring (19A), coupling ring (21) and rollers (20), flat springs (97), steel balls (96) and spring yoke (98). Install two ½ - 13 NC hook bolts into tapped holes of cylinder (6). Using crane, lift cylinder assembly straight off of pintle (5), making certain pistons (8) do not fall from cylinder and being careful not to tilt cylinder, which will scratch cylinder bushing. If cylinder is frozen to pintle, press pintle out of case before attempting to separate the cylinder bushing and pintle.

## NOTE!

See instructions on pintle removal, found later in this subsection.

Install two 5/8 - 11 NC hook bolts into tapped holes of rotor (16), then, using a crane, lift from pump case. Remove rotor bearing shims (14). If inspection and cleaning of slideblock (82) and case is necessary, see appropriate instruction bulletin for control, then remove control. To disassemble indicator (88), remove threaded indicator bushing (87) and pull indicator stem assembly from case. Install two 5/8 - 11 NC hook bolts into slideblock (82) and lift from case using crane. Case liners (85) are doweled to pump case and slideblock liners (84) are doweled to slideblock. If liners are removed, be sure to mark liners so they can be returned to the original position. If pintle needs to be reground or replaced, set pump case, open end down, in a press with a capacity of at least 250 tons. Insert a piece of wood inside case, directly in line with pintle, so when pintle drops from case, it will not be damaged. The pintle has a taper of .005" per inch of length, therefore will drop from case after it is pressed a short distance. If thrust rings (18) and/or spacer rings (17 & 17A) need to be removed from rotor, insert a brass rod into holes tapped for 1" pipe on the (bottom bearing end) of the rotor. Drive thrust rings from rotor by striking brass rods alternately on either side of rotor. Should it become necessary to separate the rear case (123) from the middle case (56), install three (3) ½ - 13 x 1 ½" hook bolts into tapped holes of rear case and jack from middle case.

## VIII. INSPECTION



ALWAYS WEAR SAFETY GOGGLES WHEN USING SOLVENTS OR COMPRESSED AIR. FAILURE TO WEAR SAFETY GOGGLES COULD RESULT IN PERSONAL INJURY.

### A. PINTLE COVER RELIEF VALVE

See Figure 19. Inspect plunger (103) for damage or burrs. Lightly polish with fine emery cloth to remove burrs. DO NOT grind O.D. of plunger. Remove foreign material from plunger and replace if necessary.

## B. OPTIONAL SUCTION CHECK VALVE

See Figure 15. Inspect disc (209) for freedom of movement. If disc sticks to seat, clean thoroughly with a NONFLAMMABLE solvent or compressed air. Disc can be lightly scored to prevent sticking. Remove foreign material from all passages.

## C. OPTIONAL HIGH PRESSURE RELIEF VALVE

See Figure 15. Clean plunger (485) thoroughly and remove foreign material from all passages in relief valve body (450). Clean all O-ring grooves and inspect O-rings for cracks and deterioration. Replace if necessary.

## D. OPTIONAL BACK PRESSURE RELIEF VALVE

See Figure 16. Inspect gasket (227) and O-rings (231 & 234) for damage or deterioration. Inspect plunger for scoring. Polish with light emery cloth and replace if necessary. Plunger seat must be smooth. Plunger (238) must move freely in body.

## E. SHUTTLE VALVE W/SUPERCHARGE RELIEF VALVE

See Figure 17. Inspect O.D. and seat of supercharge relief valve plunger (256). If necessary, polish lightly with fine emery cloth to clean up O.D. of plunger. DO NOT grind O.D. of plunger. Remove foreign material from plunger seat in valve body. The seat is a lapped fit. Relapping can be done to reseal plunger if seat is lightly scored.

Inspect I.D. of plunger bore, O.D. of plunger and orifices in shuttle valve plunger (264). If necessary, lightly polish O.D. of plunger with fine emery cloth. DO NOT grind plunger O.D. Replace if necessary. Remove foreign material from plunger I.D.

Clean orifices in plunger with NONFLAMMABLE solvent or compressed air. Do not insert any object into orifices. Remove foreign material from all passages in valve body.

## F. OPTIONAL GEAR PUMP

See Figure 14. Inspect all gear pump components for signs of wear. Inspect stub shaft (25) and bearing (24). Measure and record gear pocket depth in housing (72C) and wear in cover (73). Measure and record height of gears (22 & 23). Add housing and cover depths. Subtract gear height. The remainder is the actual running clearance. Normal running clearance is .003" - .005".

## G. OPTIONAL GEAR PUMP RELIEF VALVE (Filter Manifold Included).

See Figure 18. Inspect all O-rings (276, 284 & 288 or 289) for damage or deterioration and replace if necessary. Inspect O.D. of dashpot (281) and bore and O.D. of plunger (279) for burrs of foreign material. Lightly polish with fine emery cloth to remove burrs. If polishing doesn't remove burrs, replace part. DO NOT grind O.D. of plunger.

Inspect plunger bore of manifold body. Lightly polish if burrs or foreign material are present. Remove foreign material from all passages.

## H. SHAFT SEAL

See Figure 13. Inspect shaft seal (27) for cracks, cuts, hardening or deterioration. If a replacement is needed, tap seal from shaft seal gland (71) and press new seal into cover until it bottoms out against shoulder. The seal must be installed squarely into gland, otherwise leakage will result.

## I. RADIAL PISTON PUMP

See Figure 13. Clean all parts thoroughly, removing dirt, chips and foreign matter. Inspect all bearings for pitting or seizing. Inspect pistons and their bores for cracks, scratches or indications of wear. Inspect working surfaces of pintle, cylinder bushing and thrust rings. Inspect slideblock and case liners for grooves and cracks. A mark is scribed in the bushing and cylinder. If the bushing has turned inside the cylinder, the marks would not line up. When marks don't line up, the entire cylinder, bushing and pintle assembly must be replaced. Inspect pintle orifice and clean with compressed air. Do not insert any tool into the orifice which could accidentally change the size of the orifice.

# IX. ASSEMBLY

## NOTE!

Clean all parts, then lubricate with hydraulic fluid prior to assembly. If bearings must be heated to ease assembly, heat to 275°F. NEVER heat bearings in excess of 275°F.

## A. REAR CASE TO MIDDLE CASE

See Figure 13. Gasket (29) must be positioned properly to prevent blocking lubrication hole at top of case, near center. Assemble rear case (123) to middle case (56) with gasket (20) in correct position. Use screws (72A) to secure rear cover to middle case. NOTE: THIS IS A PRESS FIT.

## B. RADIAL PISTON UNIT

### 1. Pintle

If pintle (5) was removed, set rear cover- middle case assembly

in a press, open end up. Approximately 100 tons of force is needed to press pintle into case. Apply "Molycoat" to large tapered surface of pintle to provide lubrication during assembly. Locate pintle with key (77). Position a sleeve over small pintle end, against large diameter shoulder. Install pintle flush with back of rear case. Cylinder bushing (7) and pintle (5) have a .032" taper per inch of length. Clean pintle and bushing surfaces. Using a crane, suspend cylinder and bushing assembly above pintle, large end of bore down, then slowly lower assembly over pintle until cylinder begins to become tight on pintle. Avoid scraping against edges of pintle ports. Do not rest entire weight of cylinder on pintle as it will become too tight and damage bushing. At this point the pintle should project past cylinder bushing an amount described in "IV" SPECIFICATIONS. See Figure 5. Write down this dimension. This is the "c" dimension—the base figure used in shimming the pump. Remove cylinder from pintle.

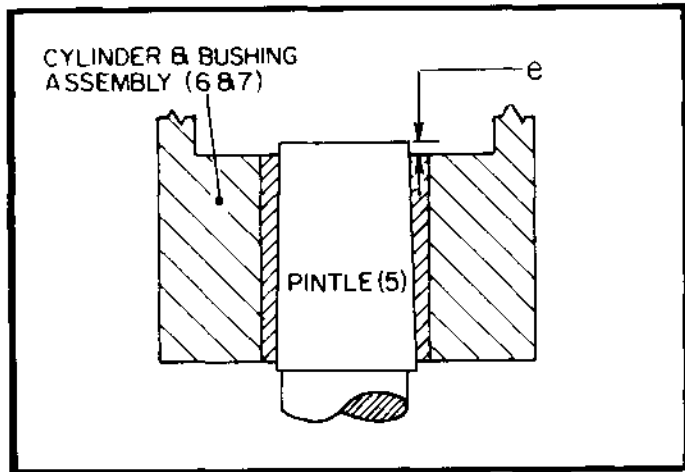

Figure 5. Basic "c" Dimension (Cylinder "tight" Position). (508644)

## 2. SLIDEBLOCK

Install a minimum of eight shims (14) of .010" thickness in rotor bearing counterbore of slideblock (82). If "c" measurement was less than .120", add one additional shim for each .010" less. Install rotor bearing outer race (9), with "thrust" flange down, into slideblock. Install steel case liners (85) and measure thickness of bronze slideblock liners (84). Liners must be within .005" thickness of each other. The thicker pair should be installed on the bottom.

Lower slideblock (82) into case and check clearance between bronze liners and slideblock using a feeler gage. The required clearance between bronze liners and slideblock is listed in "IV" SPECIFICATIONS.

## 3. ROTOR

If spacers (17 & 17A) and thrust rings (18) were removed, press into rotor evenly. Install rotor bearing inner race (9) onto rotor, then rotor cover bearing (10) onto rotor cover (65). Bearing race must be tight against hub shoulders. Lubricate bearings, place rotor assembly into slideblock and spin

rotor to make sure bearings turn freely. Lubricate mating surfaces of pintle (5) and cylinder bushing and install cylinder (6) onto pintle. Cylinder must turn freely on pintle. With cylinder resting on inside rotor face, measure pintle projection.

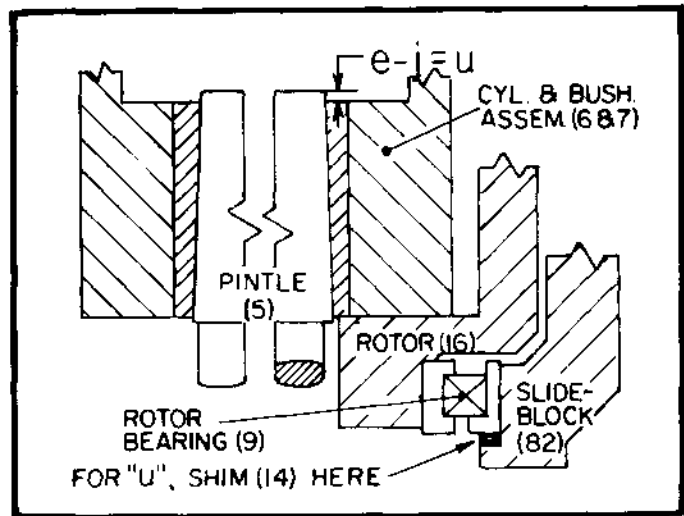

Figure 6. Cylinder "Off-of-Tight" Position. (508644)

See Figure 6. Pintle should project beyond cylinder by an amount equal to: "e" dimension minus .050" (j). Add or remove rotor bearing shims (14) for correct off-of-tight position of cylinder. This is the "u" dimension. Write it down.

## 4. DRIVESHAFT

Lift cylinder off of pintle and place a .187" thick spacer ring or three equally spaced blocks .187" thick, inside rotor. Position cylinder on pintle so it rests on spacer or blocks. Place coupling ring (21) and coupling flange (19), without rollers, into cylinder end. Remove driveshaft (1) assembly from front housing (See section VII - j, Shaft Removal). Install front housing with gasket (29), then tighten mounting screws (72A). If removed, fit front driveshaft bearings (11) on shaft with outer race "thrust" sides facing seal (27). Install locking washer (4), tighten nut (3) to hold bearing against shaft shoulder and bend one tang of washer to touch locknut (3). Remove any shims (15) from counterbore in front housing. Push shaft, with coupling spacer (2), through housing firmly. Press outer bearing race in completely and measure from top of outer race to face of front housing, then write it down. The driveshaft is now resting on coupling flange (19), which is resting on cylinder, thus eliminating the required cylinder end play of .005" - .010". Remove driveshaft, insert shims (15), check measurement. Repeat procedure until this measurement is .005" - .010" larger than original measurement. A gap of .005" is needed between seal gland (71) and face of front housing. To accomplish this, place shims (15) between outer driveshaft bearing (11) and gland until a .005" gap is obtained without gasket (28) in place. Install seal (27) into gland, position gasket properly, then secure gland to housing with screws (71A). Remove front housing ring from cylinder, cylinder from pintle and .187" spacer ring from rotor.

## 5. CYLINDER

See Figure 7. Insert pistons (8) into cylinder, then lower cylinder assembly onto pintle, stopping about two inches from actually resting on pintle. Install spring yoke (98) onto rear shaft bearing (12), balls (96) into yoke and flat springs (97) onto balls (seven on each side) in each side of yoke. Lower cylinder until it rests on springs. To determine spring deflection, measure from bushing face to end of pintle. Install shim(s) (15A) under bearing (12) to obtain a measurement of .380" minus the "u" dimension, which was recorded in step No. 3. "Thrust" face of rear driveshaft bearing (12) must face DOWN. Install coupling ring (21) and rollers (20). Piston ring (19A) should have a free fit in cylinder bore. Install ring onto coupling flange (19) and coupling flange into cylinder.

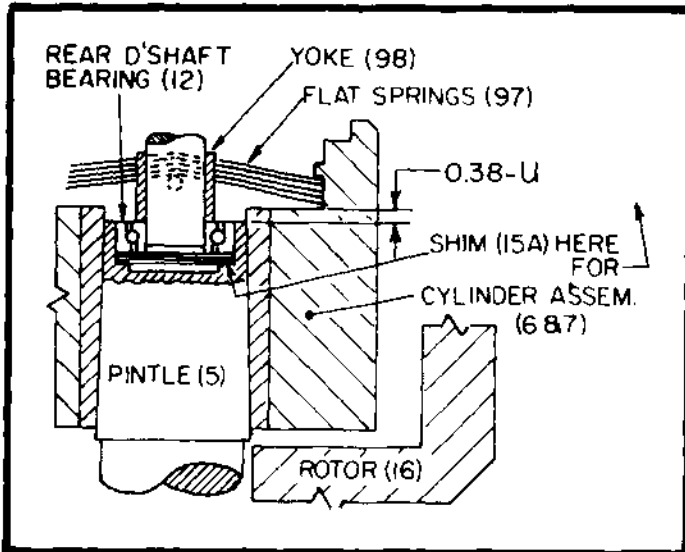

Figure 7. Spring Deflection Shimming. (508644)

## 6. ROTOR COVER

Match "0" mark on rotor cover (65) with "0" mark on rotor (16) and tighten cover screws (66) evenly. There should be approximately .062" clearance between rotor and cover with cover tight. Install new lock wire (106).

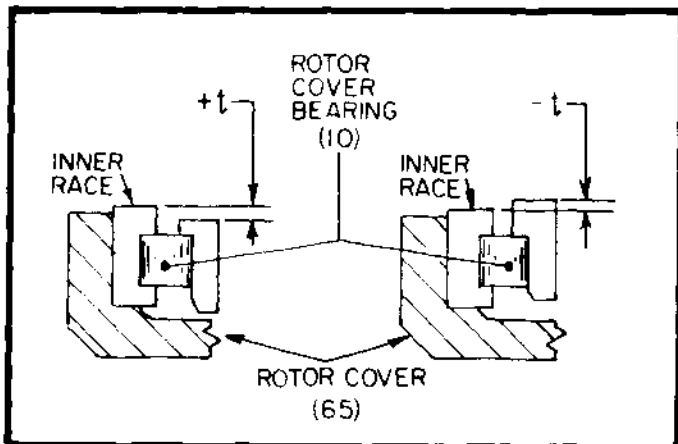

Figure 8. Initial Roller Bearing Race Projection. (508644)

See Figure 8. Measure height difference between the faces while the outer race of the rotor cover bearing (10) is resting on the roller faces. If rotor cover bearing is not being replaced, this dimension must be checked, but the rotor cover and slideblock cover must be separated from the pump. In either case, record as "+ t" if inner race projects or as "- t" if outer race projects.

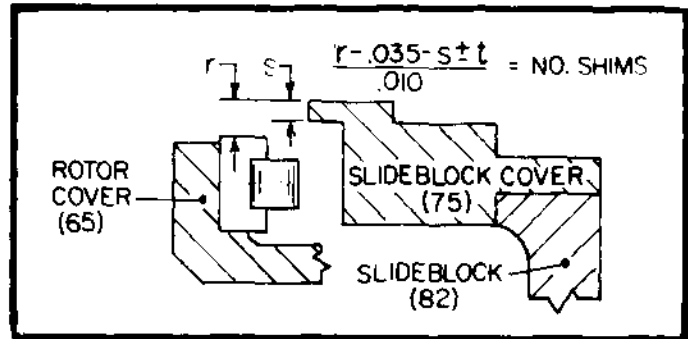

Figure 9. Cover Bearing Shim Determination. (508644)

## 7. SLIDEBLOCK COVER

See Figure 9. If rotor cover bearing is replaced, measure width of bearing bore in slideblock cover and record as dimension "s". Secure slideblock cover to slideblock using two cover screws without the cover bearing's outer race. Measure distance from top face of slideblock cover to top face of rotor cover bearing's inner race. Record this dimension as "r".

Calculate number of .010" shims (13) needed using this formula:

$$\frac{(r - .035 - s) + t \text{ (from step No. 6)}}{.010"} = \text{Number of Shims}$$

Install required shims and outer race of cover bearing into slideblock cover (75). Secure cover to slideblock with screws (74). Lock screws together with lock wire (106).

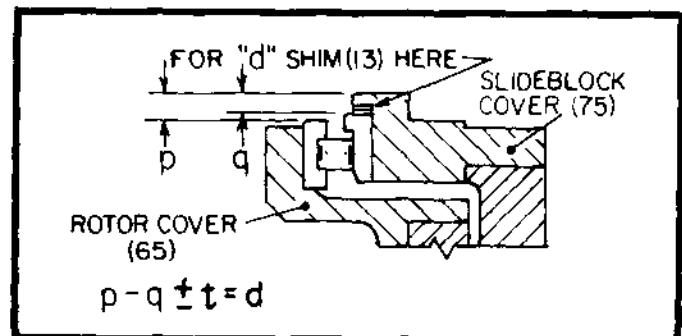

Figure 10. Cover Bearing Shim Check. (508644)

See Figure 10. If cover bearing was not replaced, secure slideblock cover to slideblock with screws (74). Lock screws together with lock wire (106). To check shimming, measure from top face of slideblock cover to the rotor cover bearing's

outer race. Record this dimension as "q". Next, measure from slideblock cover to the inner race and record as the "p" dimension. Calculate as follows:

$$p - q \pm t = d$$

Add or remove shims to obtain correct "d" dimension.

See Figure 11. Place spacer ring (68) onto slideblock cover without shims (67) in place.

With Gear pump -- For housing with gear pump, measure from gear pump cover (73) to gasket surface of gear pump housing (72C). Record measurement as "k".

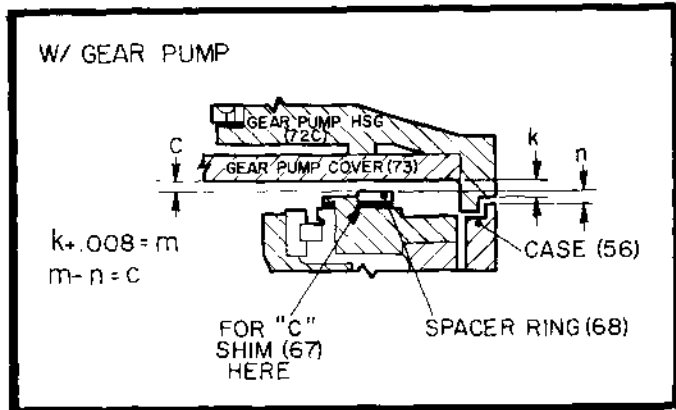

Figure 11. Slideblock End Clearance W/Gear Pump. (508644).

See Figure 12. Without Gear Pump --- For housings (72) without gear pump, measure from face of housing to gasket surface of same housing.

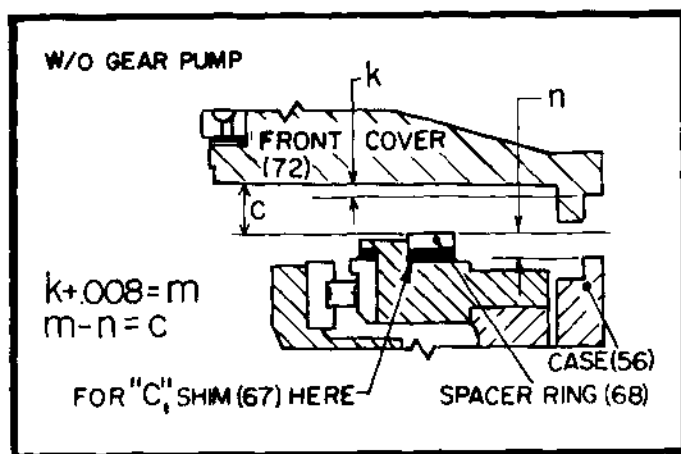

Figure 12. Slideblock End Clearance W/O Gear Pump. (508644)

**ALL HOUSINGS** --- To compensate for gasket (29) thickness, add .008" to "k" and record as "m". Measure from end of case to face of spacer ring (68). Record as "n", then subtract "n" from "m" (m - n). The difference needed is listed in "IV" SPECIFICATIONS. Add or remove shims (67) beneath spacer ring (68) until this dimension is achieved. Maximum clearance dimension can be exceeded slightly.

## B. FRONT HOUSING AND SHAFT ASSEMBLY

See Figure 14. With Gear Pump -- Place gears (22 & 23) into respective pockets of housing (72C). Position cover (73) and gaskets (70) onto housing and secure with cover screws (69). Reinstall lock wire (106) through all screw heads. Reinstall driveshaft (1A) being certain to line up key (26) with keyway in drive gear (22). NOTE: Gear (22) must be sliding fit over shaft and key. Install washer (4) and nut (3), then screws (71A). Reinstall drive key (125).

**ALL HOUSINGS**--- Position gasket (29) on middle case (56), making certain the uptapped porting hole is not blocked, then secure front housing assembly to case using screws (72A or B).

## C. PINTLE COVER

See Figure 19. Insert pintle check valve assembly into pintle being sure body (107) seats on shoulder of pintle. Reassemble pintle relief valve as follows: Install plunger (103), spring (100), washer (114), shims (101) and cap (99) with gasket (102). Tighten cap securely. Fasten cover and O-rings (81 & 81A) to rear case using screws (80B). Install plugs (104) on top of screws (80B). Fasten screws (80A) to rear housing (123).

## D. HIGH PRESSURE RELIEF VALVE

See Figure 15. If seat (491) needs to be replaced, press new seat into body using spacer (490) and flange (487), then draw down on screws (488). Insert plunger (485) and spring (484) into body, then install O-ring (480) and operator head (453). Secure operator head to body with four socket head cap screws (452) and tighten securely. Install O-ring (493) into groove of relief valve body, then secure to pump or suction check valve body using four socket head cap screws (450A) and tighten.

## E. BACK PRESSURE RELIEF VALVE

See Figure 16. Place O-ring (231) into groove then secure BPRV body (235) to suction body using four socket head cap screws (236) and tighten securely. Insert washer(s) (230) into plunger (238) and plunger into body. Insert spring (229) and cover (226) onto body, secure with four socket head cap screws (225) and tighten.

## F. SUCTION CHECK VALVE

See Figure 15. Insert check valve assembly (208, 220, 209, 210) into body, against shoulder. Reinstall O-ring (205) and flange (204), securing with four socket head cap screws (204A).

### G. SHUTTLE VALVE W/SUPERCHARGE RELIEF VALVE

See Figure 17. Install O-ring (267), check valves (265), then O-rings (266).

### NOTE!

Check valves must be installed with free flow arrow (stamped or printed on side of valve) pointing outward, toward flange.

Shuttle Valve— Insert plunger (264) into bore of body (250). Install springs (263), O-ring retainers (262) and O-rings (261). Secure each flange (260) to body using four socket head cap screws (260A).

Supercharge Relief Valve Assembly -- Insert shim(s) (257)

into plunger (256) and plunger into body (250). Install spacer (255) and spring (254). Install gasket (253) and cover (252), then secure with four socket head cap screws (251). Secure flange (260) to valve body to pump using eight socket head cap screws (260A). Tighten securely. Secure valve body to pump using eight socket head cap screws (250A). Tighten to 20 - 25 ft-lbs (27, 0 - 33,8 Nm.)

### H. GEAR PUMP RELIEF VALVE (Filter Manifold Included).

See Figure 18. Install O-rings (288 & 289) onto filter manifold, if used. Install filter manifold (290) and GPRV manifold (279) onto pump, and secure with four socket head cap screws (278). Install all plugs and O-rings that were removed. Insert plunger (279) into manifold bore, spring (280) onto plunger O.D. and dashpot (281) into plunger bore. Install shim(s) (282) spacer (283) and cap (285) with O-ring (284). Tighten cap securely.

---

### O RING SIZES

Cross Section X O.D. Duro  $\pm$  5

ITEM			ITEM		
78	3/16 x 4 1/8	90	276	3/32 x 1/2	70
81	1/8 x 8 1/2	70	248	1/8 x 1 3/4	70
81A	1/8 x 1 1/4	70	286	5/64 x 3/8	70
119	1/8 x 1 1/2	90	288	1/16 x 5/8	70
128	1/8 x 3 5/8	70	289	1/8 x 2 3/8	70
133	1/16 x 5/8	70	451	3/16 x 2 1/2	90
134	3/16 x 2 3/8	70	456	1/8 x 1 1/8	70
201	3/16 x 4 1/8	90	458	1/16 x 7/16	70
205	3/16 x 4 1/8	90	466	1/16 x 7/16	70
231	3/16 x 2 1/2	70	471	3/32 x 3/4	90
234	3/16 x 2 5/8	70	480	3/16 x 2 7/8	90
261	1/8 x 1 7/8	90	481	3/32 x 3/4	90
266	1/8 x 13/16	70	489	3/16 x 4 1/8	90
267	1/16 x 1/2	90			

---

### OILGEAR EXCHANGE SERVICE

---

Standard replacement pumps and motors are available to users of Oilgear equipment where comparable units will be returned in exchange. These rebuilt and tested replacements are usually carried in stock for quick delivery, subject to prior requests. When standard replacements must be modified to replace units which are special, shipment will depend on availability of parts and necessary assembly and test time.

To obtain this service, place an order for an exchange unit and for repair of the worn pump or motor (give serial number and type designation). The replacement will be shipped F.O.B. our factory, Milwaukee, Wisconsin. User retains the replacement and returns the worn unit prepaid to The Oilgear Company for reconditioning and test. When the unit is reconditioned and stocked, the user is billed for either the cost of reconditioning, or a flat rate exchange price, if one has been applied to that particular type of unit.

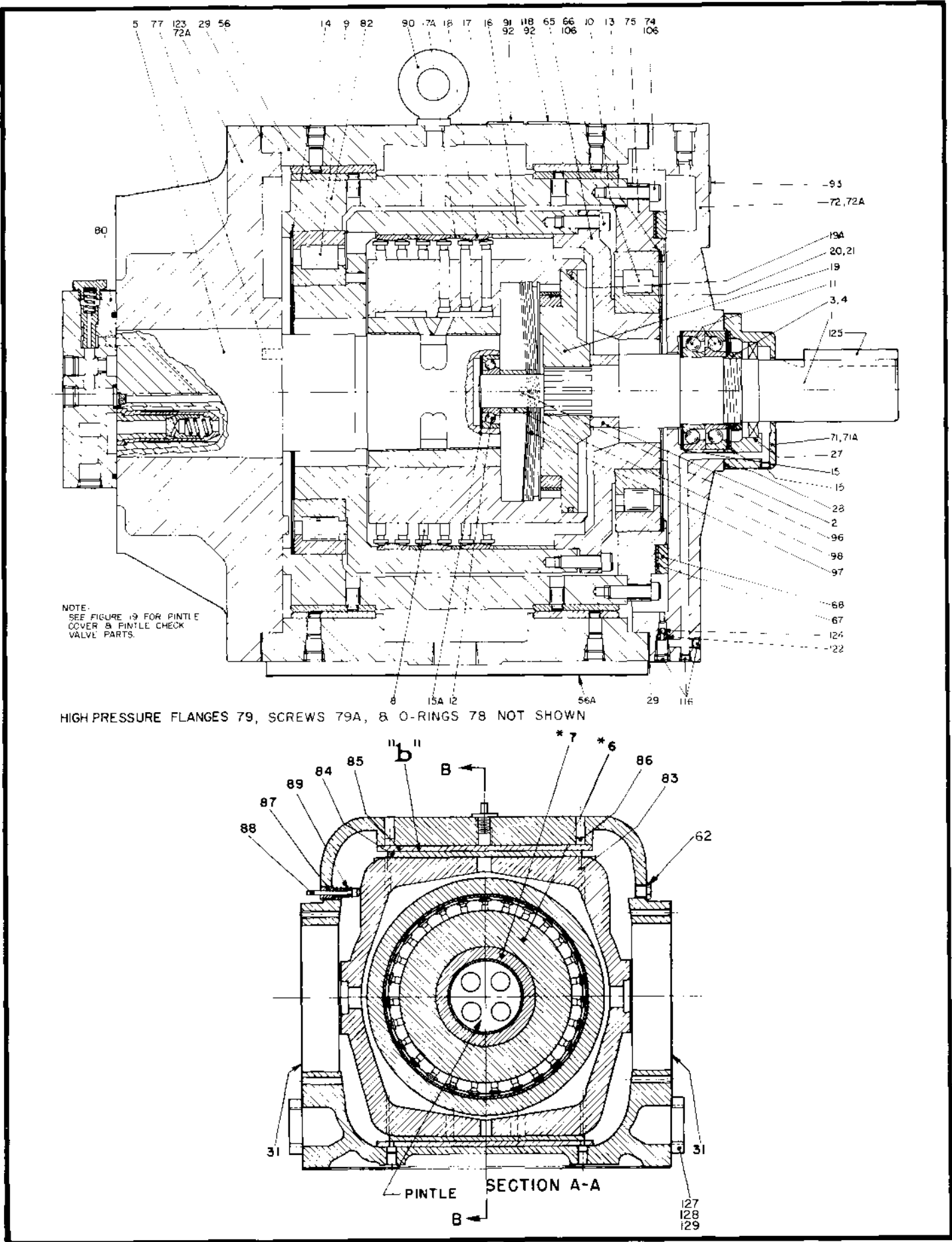

Figure 13. Type DN Pump. (508644)



# PARTS LIST TYPE "DN" PUMP

PARTS USED IN THIS ASSEMBLY ARE MADE TO OILGEAR SPECIFICATIONS. USE ORIGINAL OILGEAR PARTS TO ENSURE COMPATIBILITY WITH ASSEMBLY REQUIREMENTS. WHEN ORDERING PARTS SPECIFY TYPE DESIGNATION, PUMP SERIAL NUMBER OR "L" NUMBER OF INDIVIDUAL MODULE, ITEM NUMBER IN BULLETIN AND BULLETIN NUMBER. ALSO SPECIFY HYDRAULIC FLUID TYPE USED.

ITEM NO.	KIT	DESCRIPTION	ITEM NO.	KIT	DESCRIPTION
1.		Shaft, Drive	71.		Gland, Shaft seal
2.		Spacer, Coupling	71A.		Screw, SHC
3.	(B)	Nut, Lock	72.		Housing, Front
4.	(B)	Washer, Lock	72A.		Screw, SHC
5.	(B)	Pintle	74.		Screw, SHC
6.	(B)	Cylinder	75.		Cover, Slideblock
7.	(B)	Bushing, Cylinder	77.		Key, Pintle
8.	(B)	Piston, Radial	78.	(S)	O-ring, Flange
9.	(B)	Bearing, Rotor	79.		Flange, High pressure
10.	(B)	Bearing, Rotor cover	79A.		Screw, SHC
11.	(B)	Bearing, Front shaft	82.		Slideblock
12.	(B)	Bearing, Rear driveshaft	83.		Pin, Dowel
13.	(B)	Shims, Rotor cover bearing	84.		Liner, Slideblock
14.	(B)	Shims, Rotor bearing	85.		Liner, Case
15.	(B)	Shims, Rear driveshaft bearing	86.		Pin, Dowel
15A.	(B)	Shims, Rear driveshaft bearing	87.		Bushing, Indicator
16.		Rotor	88.		Stem, Indicator
17.		Ring, Front spacer	89.		Spring, Indicator
17A.	(B)	Ring, Spacer	90.		Eyebolt
18.	(B)	Ring, Thrust	91.		Plate, Name
19.		Flange, Coupling	93.		Plate, Rotation
19A.		Ring, Coupling piston	96.		Ball, Steel
20.		Roller, Coupling	97.		Spring, Flat
21.		Ring, Coupling	98.		Yoke, Flat spring
27.	(S)	Seal, Shaft	106.		Wire, Lock
28.	(S)	Gasket, Seal gland	115.		Plug, 1/4" NPT
29.	(S)	Gasket, Front & Rear housing	116.		Plug, 3/8" NPT
31.	(S)	Gasket, Control mounting	118.		Plate, Instruction
56.		Case, Pump	122.		Seat, Check valve
56A.	(S)	Gasket, Mounting	123.		Housing, Rear case
62.		Plug, Indicator	124.		Ball, Check valve
65.		Cover, Rotor	125.		Key, Drive shaft
66.		Screw, Rotor cover	127.		Flange
67.		Shim, Slideblock cover	128.		O-ring
68.		Ring, Slideblock cover	129.	(S)	Screw, SHC

(S) INDICATES INCLUDED IN TYPE "A" SEAL KIT.

(B) INDICATES INCLUDED IN TYPE "B" ROTARY KIT.

NSS INDICATES "NOT SOLD SEPARATELY".

NOTE: THE BALANCE OF TYPE "B" ROTARY KIT COMPONENTS FOR PUMPS CONTAINING THE OPTIONAL/GEAR PUMP MAY BE FOUND IN THE PARTS LIST FOR THE GEAR PUMP.

NOTE: THE BALANCE OF TYPE "A" SEAL KIT COMPONENTS FOR PUMPS CONTAINING THE OPTIONAL/GEAR PUMP MAY BE FOUND IN THE PARTS LISTS FOR THE GEAR PUMP AND PINTLE COVER AND CHECK VALVE.

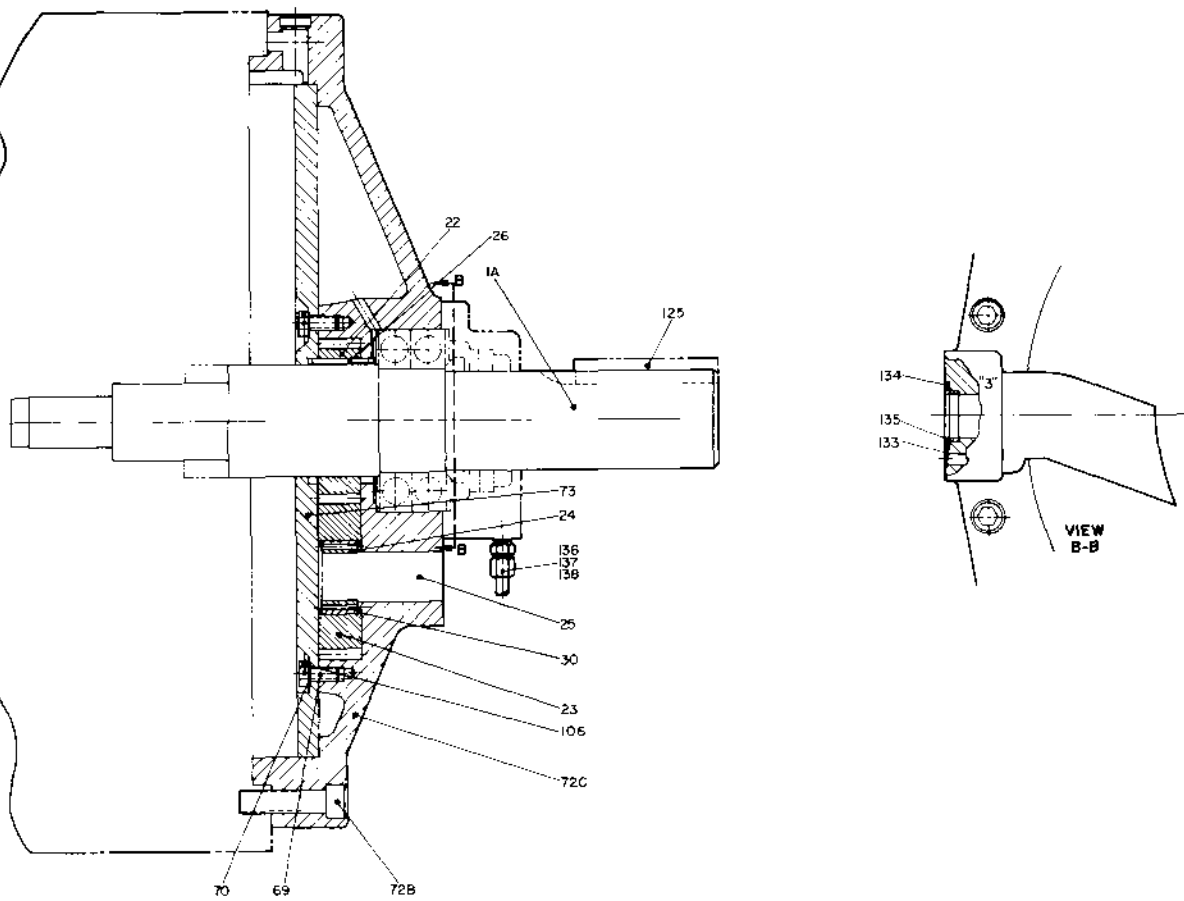

Figure 14. Optional Gear Pump. (508644)

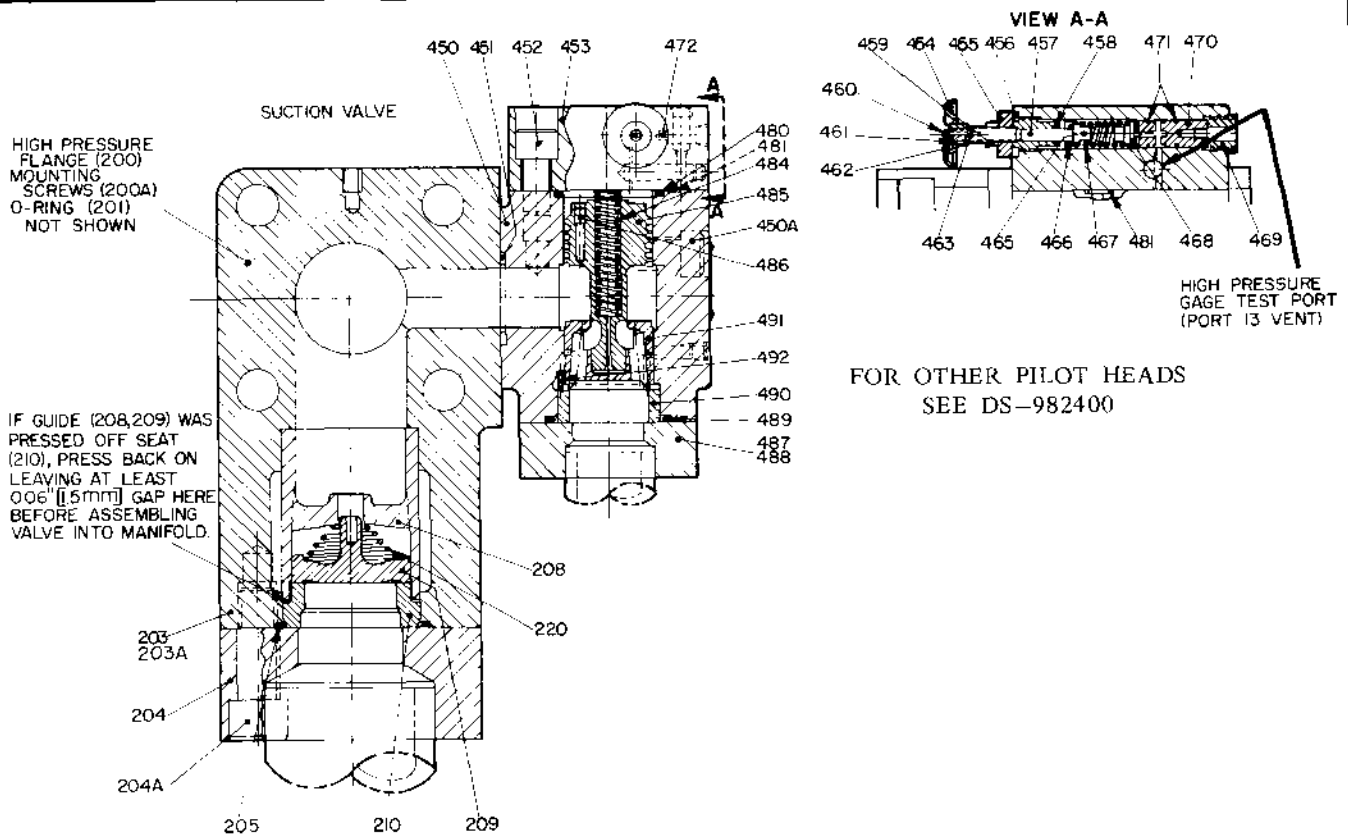

Figure 15. Optional Suction/Check Valve w/High Pressure Relief Valve. (508644)

## PARTS LIST OPTIONAL GEAR PUMP

PARTS USED IN THIS ASSEMBLY ARE MADE TO OILGEAR SPECIFICATIONS. USE ORIGINAL OILGEAR PARTS TO ENSURE COMPATIBILITY WITH ASSEMBLY REQUIREMENTS. WHEN ORDERING PARTS SPECIFY TYPE DESIGNATION, PUMP SERIAL NUMBER OR "L" NUMBER OF INDIVIDUAL MODULE, ITEM NUMBER IN BULLETIN AND BULLETIN NUMBER. ALSO SPECIFY HYDRAULIC FLUID TYPE USED.

ITEM NO.	KIT	DESCRIPTION	ITEM NO.	KIT	DESCRIPTION
1A.		Driveshaft w/coupling spacer	106.		Wire, Iron
22.	(B)	Gear, Driving	125.		Key, Driveshaft
23.	(B)	Gear, Driven	133.	(S)	O-ring
24.	(B)	Bearing, Roller	134.	(S)	O-ring
25.	(B)	Shaft, Stub	135.		Retainer
26.	(B)	Key, Driveshaft (Gear pump)	136.		Fitting
30.	(B)	Spacer, Bearing	137.		Fitting
69.		Screw, HHC	138.		Tubing
70.	(S)	Gasket, G.P. Cover screw			
72C.		Housing, Gear pump			(S) INDICATES INCLUDED IN TYPE "A" SEAL KIT.
72B.		Screw, SHC			
73.		Cover, Gear pump			(B) INDICATES INCLUDED IN TYPE "B" ROTARY KIT.

NOTE: THE BALANCE OF TYPE "B" ROTARY KIT COMPONENTS MAY BE FOUND IN THE PARTS LIST FOR THE MAIN "DN" PUMP.

NOTE: THE BALANCE OF TYPE "A" SEAL KIT COMPONENTS MAY BE FOUND IN THE PARTS LISTS FOR THE MAIN "DN" PUMP AND PINTLE COVER AND CHECK VALVE.

## PARTS LIST OPTIONAL SUCTION CHECK VALVE W/HIGH PRESSURE RELIEF VALVE

ITEM NO.	DESCRIPTION	ITEM NO.	DESCRIPTION
200.	Flange, High pressure	465.	Guide, Pilot relief valve
200A.	Screw, SHC	466.	O-ring
201.	O-ring	467.	Spring, Pilot relief valve
203.	Body, Suction check valve	468.	Poppet, Pilot relief valve
204.	Flange	469.	Cap, Pilot relief valve
204A.	Screw, SHC	470.	Seat, Pilot relief valve
205.	O-ring	471.	O-ring
208.	Cage, Check valve	472.	Plug, Orifice
209.	Disc, Check valve	480.	O-ring
210.	Seat, Check valve	481.	O-ring
220.	Spring	484.	Spring, HPRV
450.	Body, W/HPRV (Not including pilot head)	485.	Plunger, HPRV
450A.	Screw, SHC	486.	Plug
451.	O-ring	487.	Flange
452.	Screw, SHC	488.	Screw, SHC
453.	Head, Relief valve pilot	489.	O-ring
454.	Knob, Adjusting	490.	Spacer, HPRV
455.	Cap, Adjusting screw	491.	Seat, HPRV
456.	O-ring	492.	Pin, Roll
457.	Pin, Dowel		
458.	O-ring	--	Seal Kit, Pilot head (included No. 456, 458, 466, 471, 481, & 493)
459.	Nut, Jam		
460.	Screw, Machine	--	Seal Kit, Suction check (includes No. 201 & 205)
461.	Washer, Lock		
462.	Plate, Adjusting direction	--	Seal Kit, HPRV (included No. 451, 480 & 489)
463.	Screw, Adjusting		

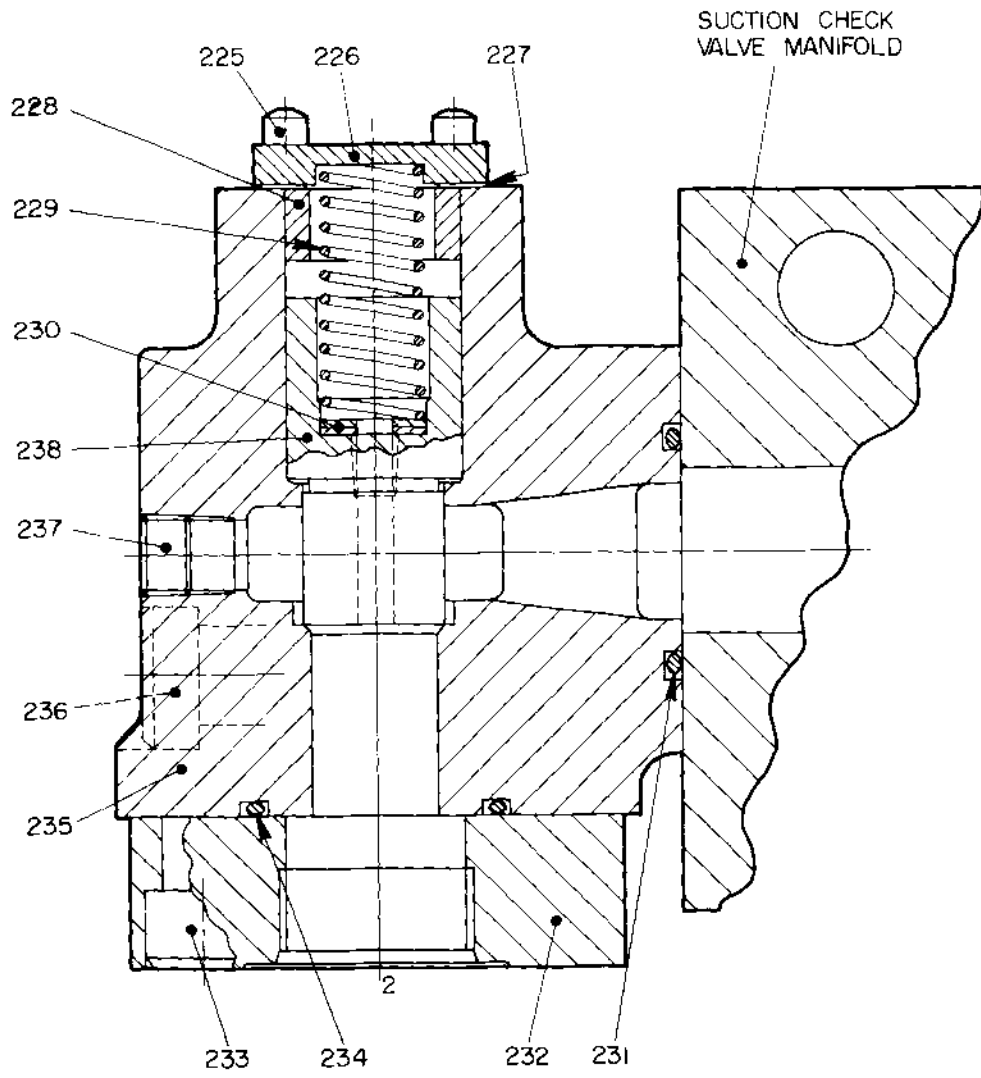

Figure 16. Optional Back Pressure Relief Valve. (508644)

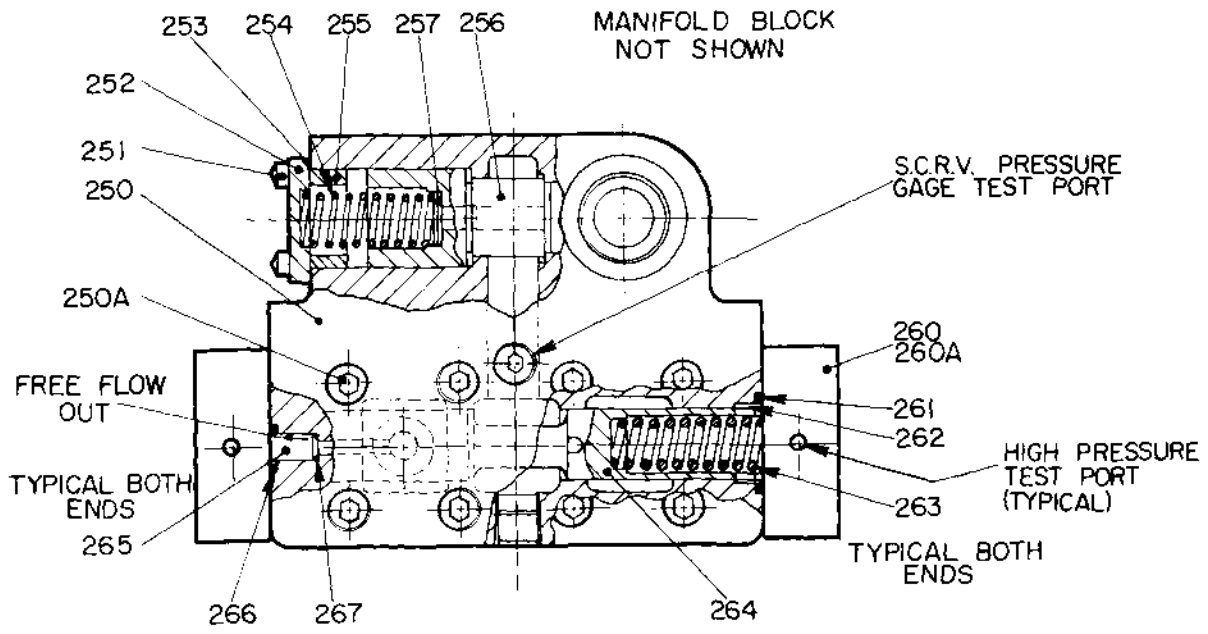

Figure 17. Optional Shuttle Valve w/Supercharge Relief Valve. (508644)

## PARTS LIST OPTIONAL BACK PRESSURE RELIEF VALVE

//  
 PARTS USED IN THIS ASSEMBLY ARE MADE TO OILGEAR SPECIFICATIONS. USE ORIGINAL  
 OILGEAR PARTS TO ENSURE COMPATIBILITY WITH ASSEMBLY REQUIREMENTS. WHEN ORDER-  
 ING PARTS SPECIFY TYPE DESIGNATION, PUMP SERIAL NUMBER OR "L" NUMBER OF  
 INDIVIDUAL MODULE, ITEM NUMBER IN BULLETIN AND BULLETIN NUMBER. ALSO SPECIFY  
 HYDRAULIC FLUID TYPE USED.  
 //

ITEM NO.	DESCRIPTION	ITEM NO.	DESCRIPTION
225.	Screw, SHC	233.	Screw, SHC
226.	Cover	234.	O-ring
227.	Gasket	235.	Body
228.	Spacer	236.	Screw, SHC
229.	Spring	237.	Plug, 1/4" NPT
230.	Washer	238.	Plunger
231.	O-ring		
232.	Flange	--	Seal Kit (Includes No. 227, 231 & 234)

## PARTS LIST OPTIONAL SHUTTLE VALVE W/SUPERCHARGE RELIEF VALVE

ITEM NO.	DESCRIPTION	ITEM NO.	DESCRIPTION
250.	Body, Shuttle valve	260A.	Screw, SHC
250A.	Screw, SHC	261.	O-ring
251.	Screw, SHC	262.	Retainer
252.	Cover	263.	Spring, Shuttle centering
253.	Gasket	264.	Plunger
254.	Spring	265.	Valve, Check
255.	Spacer	266.	O-ring
256.	Plunger	267.	O-ring
257.	Shim	--	Seal Kit (includes No. 253, 261, 266 & 267)
260.	Cover		

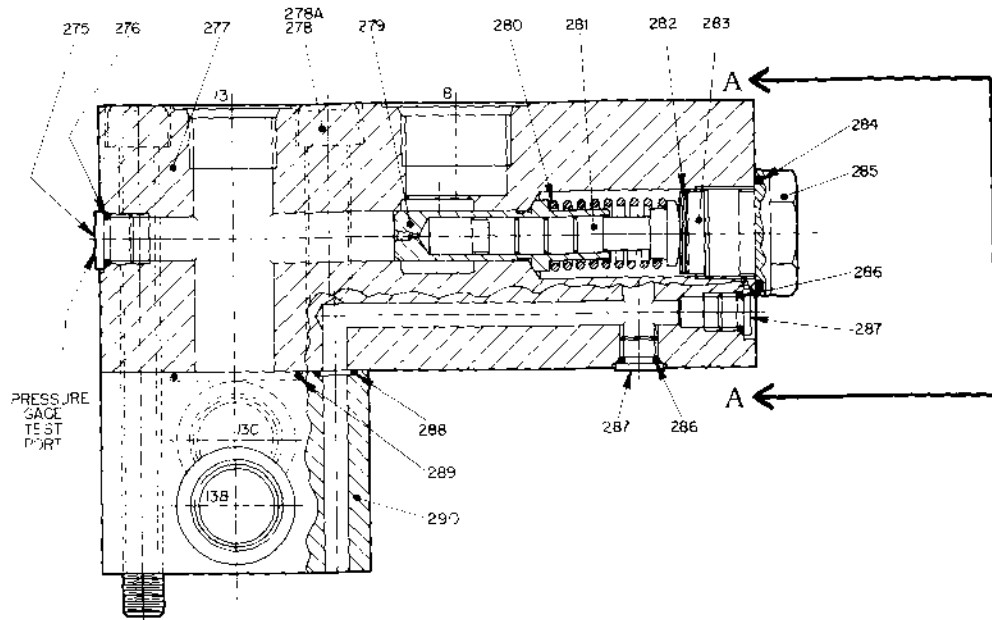

VIEW "A-A"

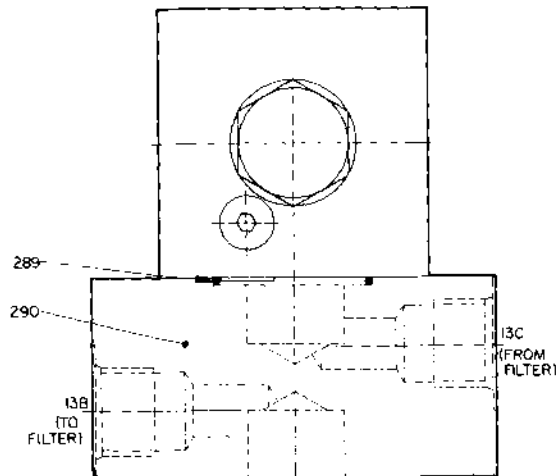

Figure 18. Optional Gear Pump Relief Valve and Optional Filter Manifold. (508644)

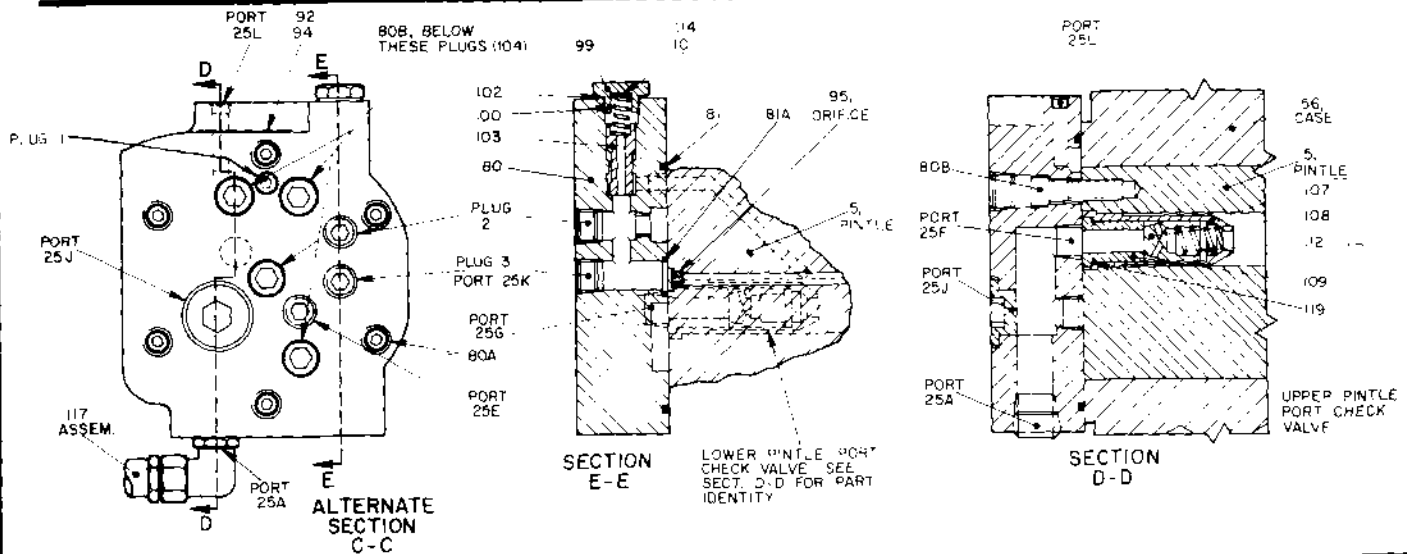

Figure 19. Pintle Cover, Pintle Cover Relief Valve and Check Valves. (508644)

## PARTS LIST OPTIONAL GEAR PUMP RELIEF VALVE AND OPTIONAL FILTER MANIFOLD

\*  
 PARTS USED IN THIS ASSEMBLY ARE MADE TO OILGEAR SPECIFICATIONS. USE ORIGINAL OILGEAR PARTS TO ENSURE COMPATIBILITY WITH ASSEMBLY REQUIREMENTS. WHEN ORDERING PARTS SPECIFY TYPE DESIGNATION, PUMP SERIAL NUMBER OR "L" NUMBER OF INDIVIDUAL MODULE, ITEM NUMBER IN BULLETIN AND BULLETIN NUMBER. ALSO SPECIFY HYDRAULIC FLUID TYPE USED.

ITEM NO.	DESCRIPTION	ITEM NO.	DESCRIPTION
275.	Plug, No. 8 SAE	284.	O-ring
276.	O-ring	285.	Cap
277.	Body, GPRV	286.	O-ring
278.	Screw, SHC (Used W/Filter Manifold)	287.	Plug, No. 6 SAE
278A.	Screw, SHC (Used W/O Filter Manifold)	288.	O-ring (Used W/Filter Manifold)
279.	Plunger	289.	O-ring (Used W/Filter Manifold)
280.	Spring	290.	Manifold, Filter
281.	Plunger, Dashpot	291.	Nameplate (Not Shown)
282.	Shim	292.	Screw, Nameplate (Not Shown)
283.	Spacer	---	Seal Kit (includes No. 276, 284, 286, 288 & 299)

## PARTS LIST PINTLE COVER, PINTLE COVER RELIEF VALVE AND PINTLE CHECK VALVES

ITEM NO.	KIT	DESCRIPTION	ITEM NO.	KIT	DESCRIPTION
80		Cover, Pintle	101		Shim, Pintle cover R.V.
80A		Screw, SHC	102	(S)	Gasket, Pintle cover cap
80B		Screw, SHC	103		Plunger, Pintle cover R.V.
81	(S)	O-ring	107		Body, Pintle C.V.
81A	(S)	O-ring	108		Plunger, Pintle C.V.
92		Screw, Drive	109		Seat, Pintle C.V.
94		Plate, Instruction	112		Spring, Pintle C.V.
95		Orifice	114		Washer, Plain
99		Cap, Pintle cover R.V.	119	(S)	O-ring
100		Spring, Pintle cover R.V.			

(S) INDICATES INCLUDED IN TYPE "A" SEAL KIT.

NOTE: THE BALANCE OF TYPE "A" SEAL KIT COMPONENTS MAY BE FOUND IN THE PARTS LISTS FOR THE MAIN "DN" PUMP AND OPTIONAL GEAR PUMP.

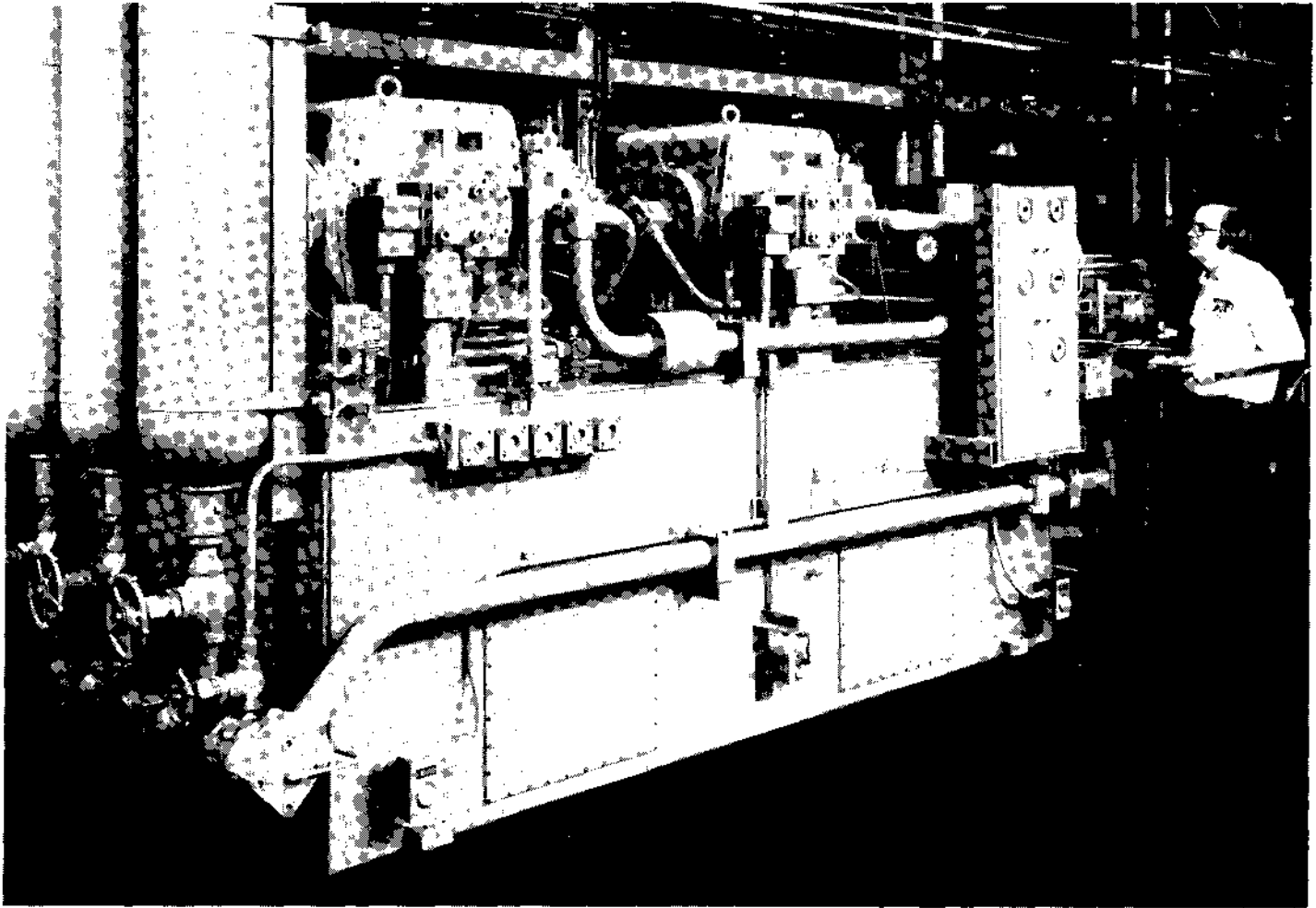

Figure 20. Pump/Motor Base w/Two (2) "DN-M" Pumps and Accessory Equipment Used to Operate Hydrostatic Pipe Tester.  
(55341)





# INSTRUCTIONS

BULLETIN 947930

## OILGEAR TYPE "C" OPPOSING ACCELERATION OPERATOR

### FOR TYPE "A," "AN" AND "AB" UNITS

#### Reference Instruction Bulletins

"A-3" Units w/o Control-----	947030
"A-8" Units w/o Control-----	947032
"A-12" Units w/o Control-----	947040
"AN-3" Units w/o Control-----	947050
"AN-8" Units w/o Control-----	947055
"AN-12" Units w/o Control-----	947060
"AB-33" Transmissions w/o Control-----	967030

#### TO THE USER AND OPERATOR OF OILGEAR UNITS WITH TYPE "C" OPPOSING OPERATORS.

These instructions are printed to simplify and minimize your work of operating and maintaining Oilgear units equipped with type "C" opposing operators. Your acquaintance with the construction, principle of operation and characteristics of these units will help you obtain optimum performance, reduce shutdowns and increase service life. We feel confident the unit will operate to your satisfaction if these instructions are adhered to. Some special operators may differ from those described in this bulletin.

#### I. CONSTRUCTION

The principal components of the type "C" opposing operator are: a small no-leak control piston; a control head; a normally open pilot plunger; an auxiliary plunger; a spring and spring guide, and valve end heads.

These opposing operators are flanged to "A", "AN" or "AB" Units opposite a main control.

#### II. PRINCIPLE OF OPERATION (See figure 2).

The type "C" opposing acceleration operator governs the slideblock shifting speed rate to prevent the accelerating or braking pressure from exceeding an adjusted setting. When the larger main control cylinder is drained, control fluid behind the smaller type "C" opposing operator piston shifts the slideblock toward the main control. When control fluid is applied behind the main control piston, the force on its larger area overcomes the force on the smaller opposing operator piston and the slideblock shifts toward the type "C" operator.

Fluid lines connect an auxiliary port of unit port "B" with operator port "10B", and an auxiliary port of unit port "A" with operator port "10A" (see Schematic Diagram, figure 2). When unit delivers from port "A", fluid flows behind the auxiliary plunger. When delivery is at port "B", fluid flows behind the normally open pilot plunger. When the pressure of fluid acting on either plunger exceeds the pressure setting of the pilot plunger spring, the pilot plunger is shifted toward the closed position to "throttle" fluid entering or being forced from behind the small operator piston; thus, slowing the slideblock shifting rate. The "slow-down" action does not begin until the operating pressure exceeds that of the pilot plunger spring setting which must be shimmed at least 250 psi below the setting of the high pressure relief valves to prevent the relief valves from opening during normal operation.

#### III. SPECIFICATIONS (see basic unit instructions).

#### IV. MALFUNCTIONS AND CAUSES

##### A. Erratic or Unresponsive Control.

1. Faulty main control (see reference bulletin).
2. Faulty radial piston unit (see reference bulletin).
3. Low control fluid pressure volume.
4. Improper high pressure relief valve setting (see reference bulletin).
5. Damaged or disconnected fluid lines from operator ports "10A" and "10B" to unit auxiliary ports.
6. Improper shimming of pilot plunger spring.
7. Binding sticking, or worn pilot or auxiliary plunger.
8. Damaged or worn operator piston and ring assembly.
9. Dirt or foreign material obstructing fluid passages.

#### V. TESTING AND ADJUSTING

Test and adjust the units high and control pressure relief valves (see basic unit reference bulletin).

Operate unit full speed in each direction with machine loaded and observe slideblock stroke indicator action during reversals.

Normally, the slideblock will surge initially about 10% of unit eccentricity and balance of movement will be slower and smooth. Slideblock should reach full stroke "F" mark at approximately the same time the driven element reaches full speed. Excessive initial surge indicates air in operator, or, sticking pilot or auxiliary plunger. Purge air in operator by loosening pipe plug (365) and operating main control to full stroke several times until solid fluid appears. Tighten pipe plug. If initial surge is still excessive, auxiliary or pilot plungers may be sticking (see Sections VI and VII for Disassembly and Inspection).

If stroke indicator moves rapidly to full stroke before driven machine reaches full speed, operator pressure

THE OILGEAR COMPANY

MILWAUKEE, WISCONSIN, U.S.A. 53204

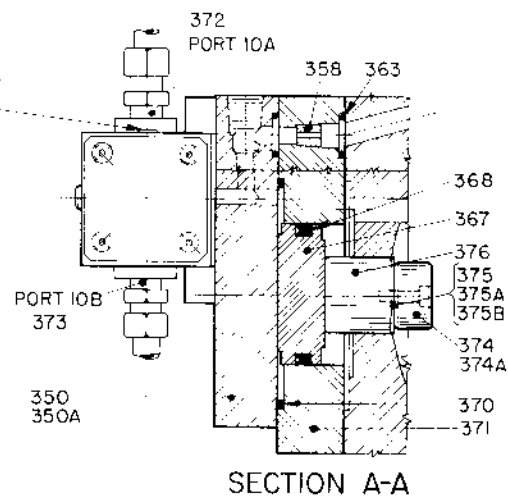
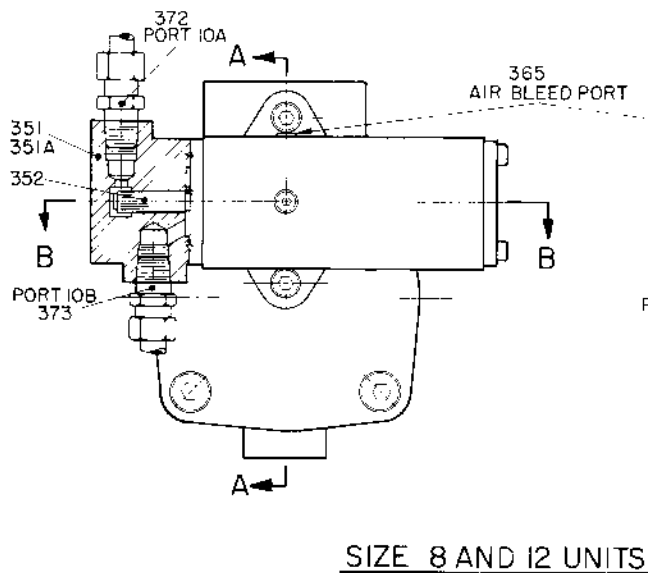
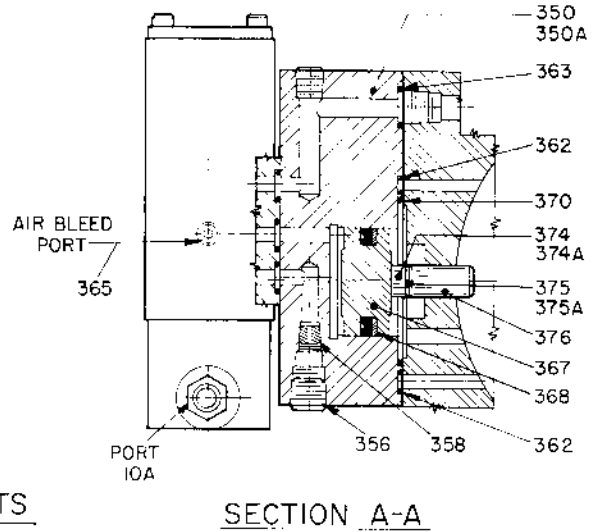
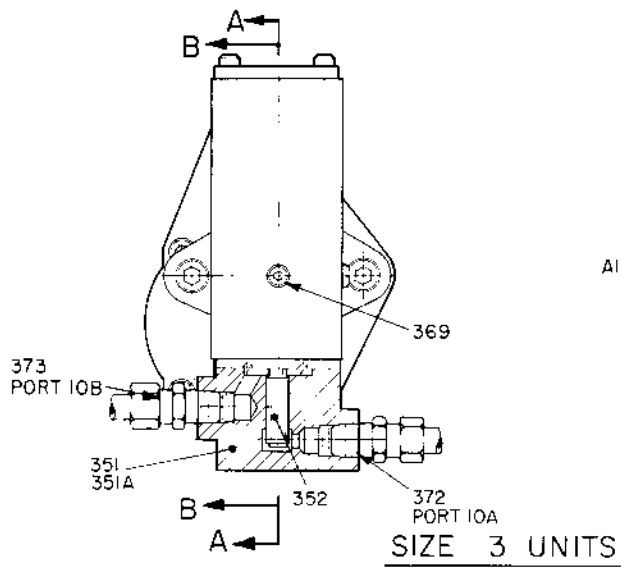
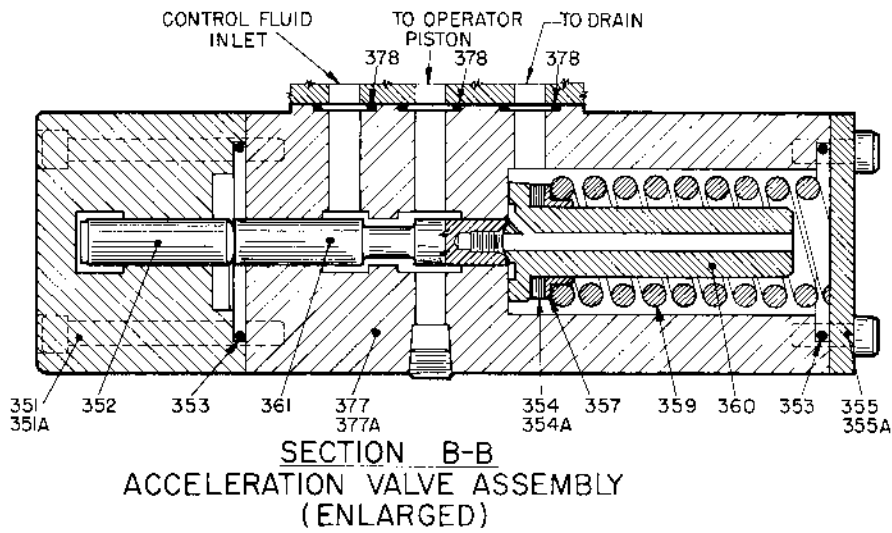

Figure 1. Parts Drawing, Type "C" Opposing Operator DS-947930 (505081).

## IX. PARTS LIST

Part No.	Description	Part No.	Description
350.	Head, Operator	365.	Plug, Pipe
350A.	Screw, Sock. Hd. Cap	367.	Piston, Operator
351.	Head, Operator End	368.	Assembly, Piston Ring
352.	Plunger, Auxiliary	369.	Plug, Pipe
353.	Seal, O'ring	370.	Seal, O'ring
354.	Shim, .003" Thick	371.	Adapter, Operator Piston
354A.	Shim, .032" Thick	372.	Tubing w/Fittings
355.	Screw, Sock. Hd. Cap	373.	Tubing w/Fittings
355A.	Cover, Spring End	374.	Spacer, Push Rod
356.	Plug, Pipe	374A.	Screw, Nylock
357.	Guide, Spring	375.	Shim, .003" Thick
*358.	Plug, Orifice	375A.	Shim, .005" Thick
359.	Spring, Pilot Plunger	375B.	Shim, .010" Thick
360.	Guide, Spring	376.	Rod, Push
361.	Plunger, Pilot	377.	Body, Acceleration Valve
362.	Seal, O'ring	377A.	Screw, Sock. Hd. Cap
363.	Seal, O'ring	378.	Seal, O'ring

Note: When ordering replacement parts, specify unit serial number, part number and data sheet (DS) number. Specify type of hydraulic fluid used when ordering o'rings and piston ring assembly.

\* Orifice plug 358 not used on all units.

### O-RING SIZES Cross Section X O.D. Duro $\pm 5$

Part No.	Unit Size					
	3		8		12	
353.	1/8 x 1-5/8	90	1/8 x 1-5/8	90	1/8 x 1-5/8	90
362.	1/16 x 11/32	70	-----	-----	-----	-----
363.	1/16 x 11/16	70	3/32 x 5/8	70	3/32 x 3/4	70
370.	1/16 x 2-3/4	70	1/8 x 2-1/2	70	1/8 x 4-1/2	70
378.	1/16 x 1/4	70	1/16 x 1/2	70	1/16 x 1/2	70

setting may be too high. Install pressure gages (0-3000 psi) in high pressure ports and observe pressure during acceleration to full stroke with an average load on machine. Initially, a peak approximately equal to high pressure relief valve setting will occur. Then, the pressure should decrease to a "steady value" until driven machine reaches full speed. "Steady Value" reading is operator pressure setting. Remove shims (354 and 354A) to lower setting to at least 250 psi below high pressure relief valve setting so relief valves do not open during normal operation. If, when main control is actuated to shift slideblock to full stroke and returned to neutral, the slideblock stays in full stroke position except for a slight drift toward neutral, the operator pressure setting is too low. Add shims (354 and 354A) to increase the setting.

## VI. DISASSEMBLY

Disconnect tubing assemblies (372 and 373) from operator. Remove screws (377A), separate acceleration valve body (377) from operator head (350) and remove o'rings (378). Disassemble acceleration valve

assembly by removing screws (355A) and cover (355). Withdraw o'rings (353), spring (359), spring guide (360) and pilot plunger (361). Remove guide (357) and shims (354 and 354A) from guide (360). Remove screws (351A) and operator end head (351). Withdraw o'ring (353) and auxiliary plunger (352) from end head.

Size 3 Units. Withdraw screws (350A) and carefully remove operator head (350). Remove o'rings (362, 363 and 370), operator piston (367) and pushrod assembly (374). Remove pipe plug (356) to gain access to orifice plug (358) (if used). Remove piston ring assembly (368) from piston (367), if replacement is necessary. Remove screws (374A) to separate pushrod spacer (374), shims (375 and 375A) and pushrod (376).

Size 8 and 12 Units. Withdraw screws (350A), carefully remove operator head (350) and operator piston adapter (371). Withdraw o'rings (363 and 370), operator piston (367) and pushrod assembly. Remove orifice plug (358) (if used). Remove piston ring assembly, if replacement is necessary. Remove screw (374A)

to separate pushrod spacer (374), shims (375, 375A and 375B) and pushrod (376).

## VII. INSPECTION

Clean all parts thoroughly and make certain fluid passages are clean. Inspect auxiliary plunger (352), pilot plunger (361), operator piston and ring assembly (367 and 368) and pushrod (376) for signs of excessive wear and replace, if necessary. Be sure the plungers move freely in their bores. relap or replace, if required. Replace o-rings showing signs of hardening, deterioration, or damage.

## VIII. ASSEMBLY

Size 3 Units. Secure pushrod spacer (374) and shims (375 and 375A) to pushrod (376) with screw (374A) and insert in case. Install o-rings (362, 363, and 370), orifice plug (358) (if used), and operator piston (367) with ring assembly (368) in operator head (350). Position operator head (350) and secure it to case with screws (350A).

Size 8 and 12 Units. Secure pushrod spacer (374) and shims (375, 375A and B) to pushrod (376) with screws (374A) and insert in case. Install orifice plug (358) (if used), o-rings (363 and 370) and operator piston (367) with ring assembly (368) in operator piston adapter (371). Insert o-ring (363) in operator head (350). Position the operator head and control piston adapter and secure them to the case with screws (350A).

Proceed on all units by inserting pilot plunger (361) in valve body (377). Place shims (354 and 354A), guide (357) and spring (359) on spring guide (360) and insert in valve body. Install o-ring (353) and secure cover (355) to valve body with screws (355A). Insert auxiliary plunger (352) and o-ring (353) in end head (351). Then, secure the head to valve body with screws (351A). Place o-rings (378) in their bores and secure acceleration valve assembly to operator head (350) with screws (377A). Connect tubing assemblies (372 and 373) to the operator. Test and adjust as described in Section V.

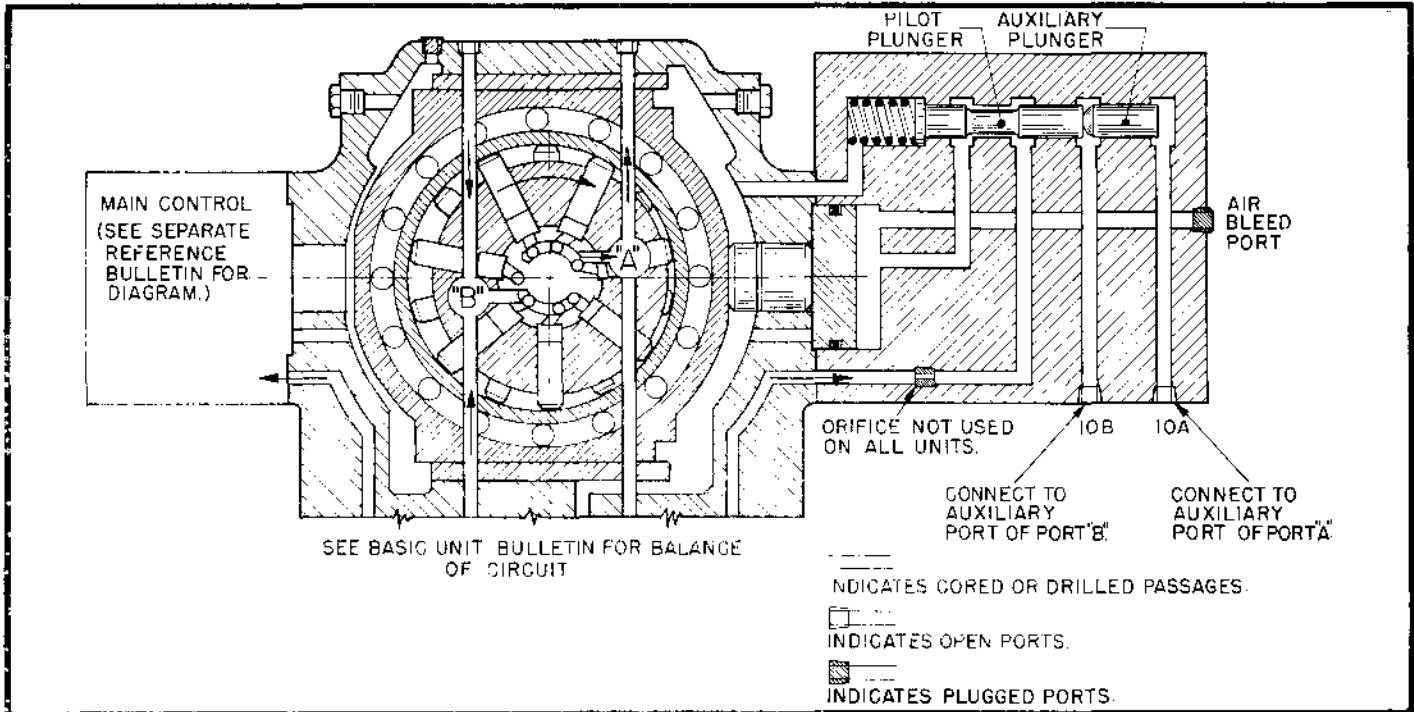

Figure 2. Schematic Diagram, Type "C" Opposing Operator (5V-10119-L).

### OILGEAR REPLACEMENT SERVICE

Standard replacement units are available to users of Oilgear equipment where comparable units will be returned for rebuild. These rebuilt and tested replacements are usually carried in stock for quick delivery, subject to prior requests. When standard replacements must be modified to replace units which are special, delivery will depend on availability of parts and assembly and test time necessary.

To obtain this service, place an order for a replacement and for repair of the worn unit (give serial number and type designation). The replacement will be shipped F. O. B. Milwaukee, Wisconsin. User retains the replacement and returns the worn unit prepaid to The Oilgear Company for reconditioning and test. When the unit is reconditioned and stocked, the user is billed the cost of reconditioning.

## THE OILGEAR COMPANY

MILWAUKEE, WISCONSIN, U. S. A. 53204