

SERVICE INSTRUCTIONS

OILGEAR TYPE "C" OR "N" MODULAR 4-WAY VALVE OPERATOR FOR "VSM" CYLINDER PREFILL VALVES

PURPOSE OF INSTRUCTIONS

These instructions are written to simplify your work when installing, operating and maintaining Oilgear Type "VSM" cylinder prefill valves and operators. Your acquaintance with the construction, principle of operation and characteristics of these valves will help you attain satisfactory performance, reduce shut-down time and increase the unit's life. Some valves and operators have been modified from those described in this bulletin and other changes may be made without notice.



Figure 1. Typical Prefill with Type "C" Modular operator (N93-024-04R).

REFERENCE MATERIAL

Piping Information	Bulletin 90011
Prefill and Control Specifications	Bulletin 86000
Size 100 (4") thru 200 (8") Cylinder Prefill and Exhaust Valves	Bulletin 986304
Size 250 (10") and Larger Cylinder Prefill and Exhaust Valves	Bulletin 986308
Flow Control Valves	Section 5, Page A5.3

I. PREPARATION AND INSTRUCTION

See reference instruction on applicable size cylinder prefill and exhaust valve. See referenced "Piping Information" bulletin and individual circuit diagram before connecting prefill to system. If "Limit switch" tell tale is used, be sure "Limit Switch Drain Port" in Modular Adapter Block is connected to drain.

II. CONSTRUCTION

Refer to Figure 2. The principle parts of this operator are a dashpot nose (310) on the control piston, a floating dashpot sleeve (302) in the rear head (300), and a module adapter block (315). Attached to the adapter block are a four-way valve operator manifold (375), a flow control module (380) and a four-way valve (390). Optional limit switch assembly (340) or visual tell tale assembly (325) may also be mounted on the module adapter block (315).

THE OILGEAR COMPANY

2300 So. 51st. Street
Milwaukee, WI 53219

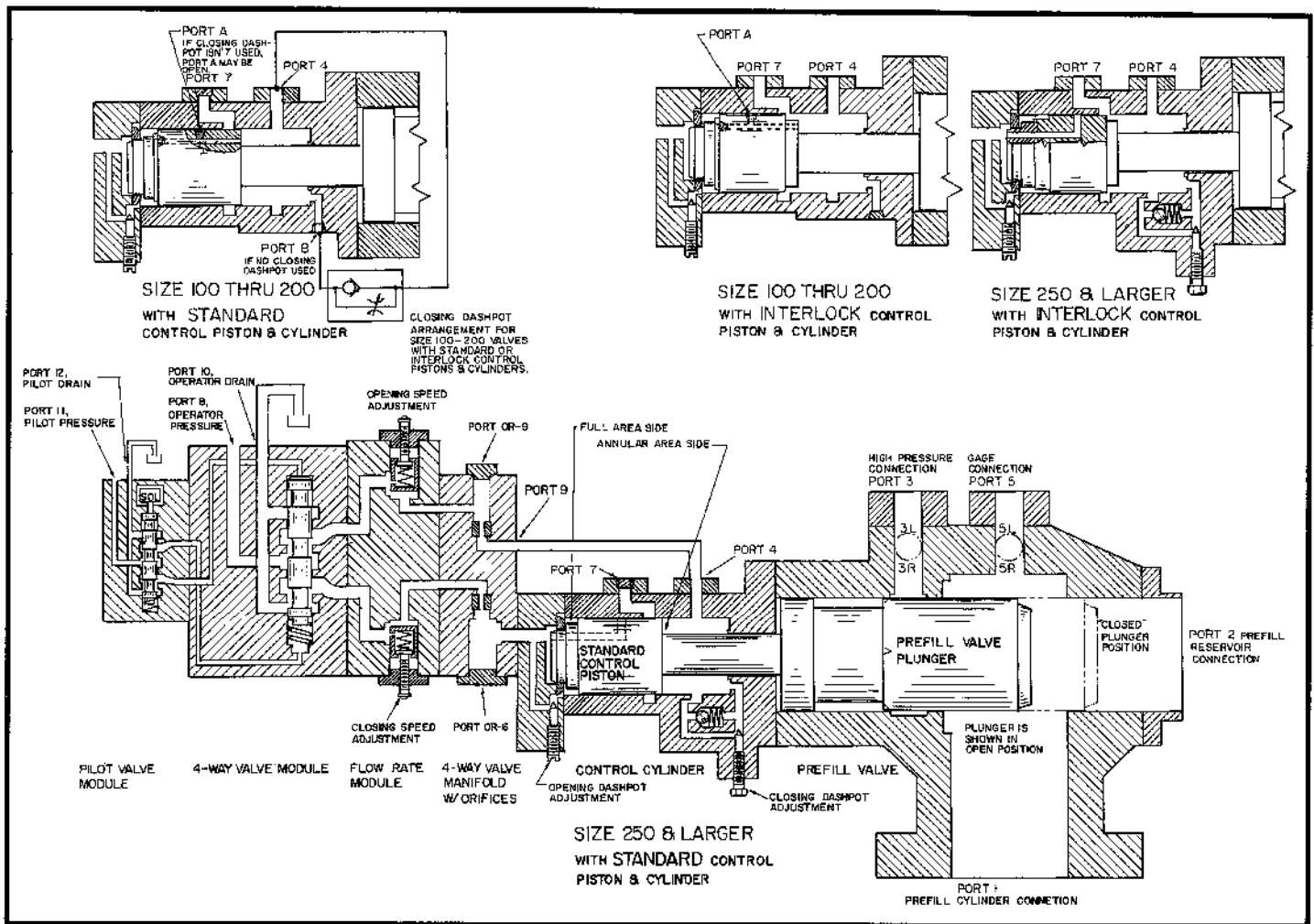

Figure 2. Schematic Cutaway Diagram, Prefill Valve with Solenoid Pilot Four-Way Valve and Meter-In to Open/Meter-In to Close Operator (5V-12040-L Sheet 1).

III. PRINCIPLE OF OPERATION

A. METER-IN OPEN, METER-IN CLOSE (with Port 9 connected to Port 4).

See Figure 2. When the solenoid of the pilot valve is de-energized, the **spool** end of the 4-way operator valve is connected through the pilot valve to drain. The operator valve spring (or pilot pressure from port 11) positions the operator spool to allow pressure from Port 8 to flow (restricted) thru the adjustable opening of the opening speed flow control valve, thru an (optional) orifice, thru Port 9 to Port 4 and to the annular area side of the control piston thus opening the prefill valve plunger. The plain control piston moves at a constant rate as fluid is forced from behind the control piston thru an (optional) orifice, against the spool of the closing speed flow control valve (compressing the spring and opening the valve fully) and allows free flow to (and thru) the directional control valve and out Port 10 to drain. An opening dashpot slows down and cushions final stroke of the control piston as flow from the dashpot area is metered out by a needle valve built with the operator.

When the pilot valve solenoid is energized; it shifts the pilot spool, directs pressure to the plunger end of 4-way operator valve and drains the spring end of the operator valve. The 4-way valve plunger shifts and pilot fluid entering Port 8 flows (restricted) thru the adjustable opening of the closing speed flow control valve, thru an (optional) orifice to the full area side of the control piston to close the prefill valve plunger. The plain control piston moves at a constant rate and fluid is forced from the annular area

of the control piston, thru an (optional) orifice, against the spool of the opening speed flow control valve (compressing the spring and opening the valve fully) and allows free flow to (and thru) the directional control valve and out Port 10 to drain.

B. METER-OUT OPEN, METER-IN CLOSE (Port 9 is blocked and pilot pressure is connected to Port 4).

See Figure 3. When the solenoid of the pilot valve is de-energized, the spool end of the 4-way operator valve is connected thru the pilot valve to drain. The operator valve spring (or pilot pressure from Port 11) positions the operator spool. Port 8 pilot pressure thru the valve is blocked by a flange at Port 9. Pilot pressure at Port 4 works on the annular area side of the standard control piston. The full area side is connected thru the flow control valves to drain. Fluid is allowed to flow (restricted), from the full area side, through the adjustable opening of the opening speed flow control valve, thru an (optional) orifice, against the spool of the closing speed flow control valve (compressing the spring and opening the valve fully), thru the 4-way valve and out Port 10 to drain. An opening dashpot slows down and cushions final stroke of the control piston as flow from the dashpot area is metered out by a needle valve built into the operator.

When the pilot valve solenoid is energized; it shifts the pilot spool, directs pressure to the plunger end of 4-way operator valve and drains the spring end of the operator valve. Pilot fluid entering Port 8 flows (restricted) through the adjustable opening of the closing speed flow control valve, thru an (optional) orifice,

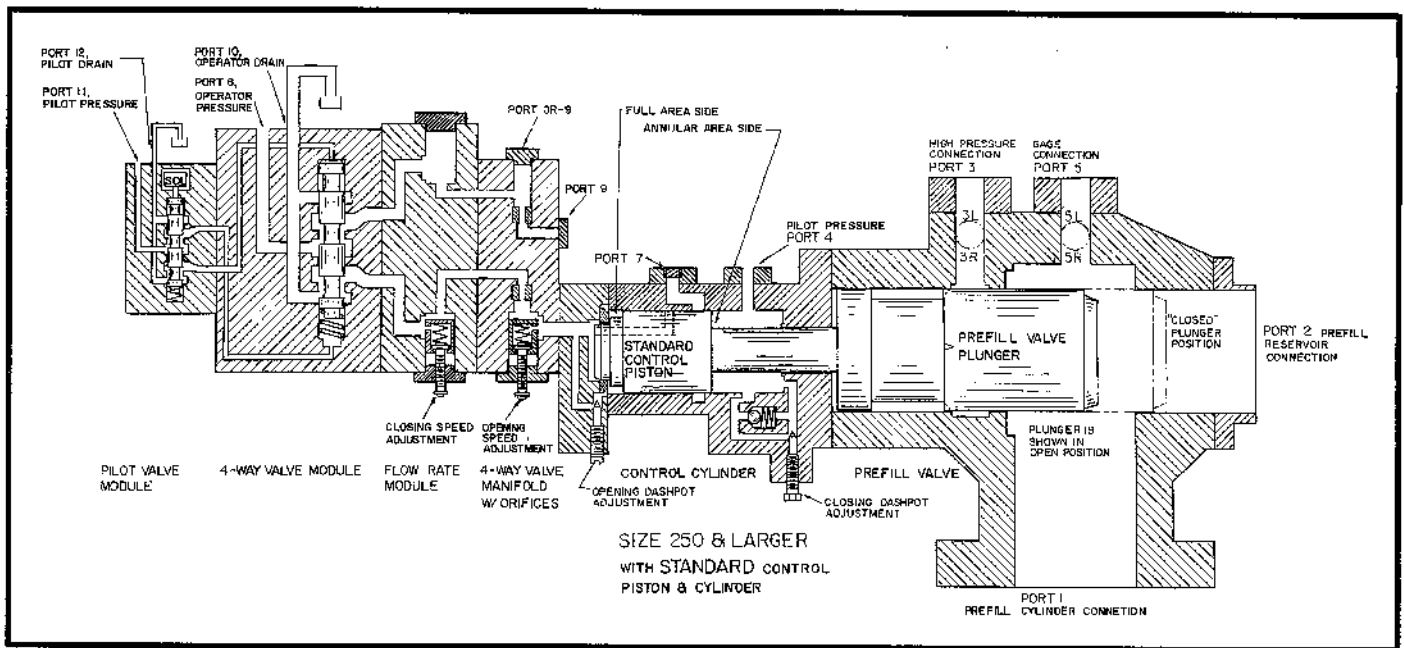

Figure 3. Schematic Cutaway Diagram, Prefill Valve with Solenoid Pilot Four-way Valve and Meter-out to Open/Meter-In to Close Operator (5V-12040-L, Sheet 2).

against the spool of the opening speed flow control valve (compressing the spring and opening the valve fully) and acts on the full area of the control piston. Pilot pressure operating on the **full** area side results in a **force** much larger than a resultant force of pilot pressure operating on the **annular** area side. Therefore, the plain control piston moves at a constant rate and fluid is forced from behind the annular area.

C. OTHER PRINCIPLES

For operation with interlock piston or adjustable closing dashpot, see referenced bulletins on Cylinder Prefill and Exhaust Valves.

IV. SPECIFICATIONS

See referenced bulletin on "Prefill and Control Specifications".

V. MALFUNCTIONS AND CAUSES

A. UNIT DOES NOT SHIFT PROPERLY

1. Inoperative or damaged 4-way valve assembly (390).
2. Opening and/or closing speed flow control valve (383) adjustments screwed in too far.
3. Plugged flow control orifices (374A or B).
4. Insufficient pilot and/or operator pressure.
5. Plugged dashpot check and/or choke valves.

VI. TESTING AND ADJUSTING

To measure prefill valve plunger stroke or observe movement, use the tell tale rod if unit is so equipped. If limit switch is used, remove enclosure cover (340) to observe rod movement. If not equipped, the optional visual tell tale assembly can be ordered from The Oilgear Company.

The opening and closing **speed** of prefill can be adjusted by flow control valves (383). Turning "in" the appropriate (labeled) adjusting screw slows speed of opening or closing. For low pilot pressure systems requiring faster prefill valve shifting speeds, remove orifice plugs (374A and 374B) found behind Port OR-6 (372) and Port OR-9 (373) plugs.

Opening or closing **dashpot** action can also be adjusted by turning "in" appropriate adjusting screw (303) or (33) to slow down the action or turning it "out" to speed it up.

VII. DISASSEMBLY

A. GENERAL (Parts drawing on Page 6).

Refer to Figure 4. It will be advantageous to tag similar parts (particularly screws, plugs and o-rings) during disassembly to be certain they don't become confused with similar parts and to ensure they will be returned to original location. Do not remove (locator) roll pins unless they are deformed or otherwise in need of replacement.

WARNING: NEVER attempt to remove or install any component or assembly while system is running. Always shut-off power and release pressure from system before servicing or testing.

B. PREPARATION

While disassembling or assembling unit, we recommend choosing an area where no traces of dust, sand or other abrasive particles, which can damage the operator and system, are in the air. We also recommend not working near welding, sand blasting, grinding benches and the likes. Place all parts on a CLEAN surface. To clean parts which have been disassembled, it is important to use CLEAN solvents. All tools and gages should be CLEAN prior to working with this unit and new CLEAN threadless rags used to handle and dry parts.

CAUTION:

Before disassembling, isolate prefill valve from reservoir and press cylinder, or drain hydraulic fluid.

Avoid allowing cylinder prefill plunger (18) movement beyond normal closed position or piston rings (19) will expand in Port 3 relief and lock plunger in body. Refer to Figure 4. Depending upon what part or parts are to be inspected, it may not be necessary to completely take apart all assemblies or disconnect piping.

C. DISCONNECTING AND DISMOUNTING

Disconnect all electrical connections and hydraulic connections to or from ports (remove flanges 379 and o-rings 377) 8, 10, 11 and 12. Withdraw any o-rings involved.

D. VALVE MODULE

While supporting the module, remove screws (390A) and pull CETOP patterned (Solenoid Pilot Operated) four-way valve (390) from the flow control rate module (380). If further disassembly of this module is required, consult individual manufacturer's literature.

E. CONTROL RATE MODULE

While supporting module, remove screws (380A) and lock washers (380B) and pull flow control rate module (380) with o-rings (381, 382, 385A) from 4-way valve operator manifold (375). Flow control valve assemblies (383) may be screwed out from module for inspection, consult referenced material. Be sure to mark which labeled assembly is for "open speed adjustment" and which is for "close speed adjustment".

F. VALVE MANIFOLD MODULE

Disconnect Port 9 flange (376) and o-ring (377) from module. Remove screws (375A) and lift the 4-way valve manifold module (375) from the top of the module adapter block (315).

G. TELL TALES (if used)

IF VISUAL TELL TALE is used, remove screws (325A) and pull guard (325) and bushing (326) from adapter (315).

IF LIMIT SWITCH is used, remove screws (341A), lift enclosure cover (341) and gasket (342) from enclosure body (340). Mark location of limit switch cam (343) on limit switch tell tale rod (355) and loosen set screw (343A). Remove screws (340A) and slide limit switch enclosure body (340) with rod bushing (326) [along tell tale rod (355)] from adapter (315).

H. MODULE ADAPTER BLOCK

Remove Screws (315A) and slide module adapter block (315) out [along tell tale rod (335 or 355)] from rear head (300). If necessary, rod seal retainer assembly parts (327, 328, 329 and 330) can be removed as well as rod bearing sleeve (318) and o-ring (319). Remove o-rings (316 and 317).

I. REAR HEAD

Remove screws (300A) and the rear head (300) can be slid out and along tell tale rod (335 or 355). The dashpot sleeve (302) and rear head locating ring (301) can be removed. If necessary, loosen jam nut (303A) and turn flow choke screw (303) out from rear head.

J. TALE ROD

Working inside the control cylinder, remove screws (310A). Tugging on the rod (335 or 355) should bring out dashpot nose (310) and rod retaining assembly. If necessary, pins (331) can be pressed out and outer rod retainer (332), washer springs (333) and inner rod retainer (334) can be removed.

VIII. INSPECTION

Clean all parts thoroughly, inspect and replace any part showing signs of undue wear. Be sure o-rings are free from nicks, cuts,

hardening, cracking or deterioration. Remove plugs from Port OR-6 and OR-9 and check orifices (374A & B). Wash all parts thoroughly prior to assembly.

WARNING - Always wear safety goggles when using solvents or compressed air. Failure to wear goggles, could result in serious personal injury.

IX. ASSEMBLY

A. TELL TALE ROD

Slide inner rod retainer (334) on to the rod (335 or 355), follow with washer springs (333) and, using roll pins (331), lock outer rod retainer (332) onto the rod. Slip the assembly into the counterbore of dashpot nose (310). Using screws (310A), secure the nose/rod assembly to the control piston inside the control cylinder.

B. REAR HEAD

Place o-ring (304) and back-up ring (305) on flow choke screw (303). Insert assembly into rear head (300) and lock in place with jam nut (303A). Insert dashpot sleeve (302) and rear head locating ring (301) in counter bore of rear head. Be sure o-ring (11) is in place, slip rear head (300) along rod and fasten to control cylinder with screws (300A).

C. ADAPTER BLOCK and SEAL ASSEMBLY

With sleeve bearing (318) and o-rings (319 and 317) in place, use screw (315A) to secure adapter head (315) to rear head (300). Inner rod seal (328) is composed of a square (cross section) rubber ring that fits around the outside of a plastic ring. **It is recommended that both parts of seal be installed simultaneously.** Note the orientation of the rod seal retainer (327). The narrow O.D. groove of the retainer must face towards the control cylinder when assembled into the adapter block - the "sharp" edges of the inner rod seal (328) must point towards the control cylinder when assembled. To force the seals into the rod seal retainer (327), place assembled inner rod seal on a flat surface and **evenly** press the retainer down on each of the inner rod seals (328). Place the square (cross section) joint ring (330) into the narrow groove of the retainer and the o-ring (329) into the remaining groove. Slide the seal assembly over the tell tale rod and into counterbore of adapter block (315).

NOTE:

Use a guide bushing behind seal assembly to keep inner rod seal (328) from popping out of retainer (327).

D. TELL TALES (if used)

Be sure rod bushing (326) is installed in visual tell tale assembly (325) or in limit switch enclosure body (340).

IF VISUAL TELL TALE is used, slide assembly (325) over the rod (335) and fasten with screws (325A).

IF LIMIT SWITCH is used, slide the enclosure body (340) over rod (355) being certain that limit switch cams (343) also slide along rod and fasten with screws (340A). Move cams (343) to locations, marked on disassembly, and tighten set screws (343A) to lock in place. Put enclosure gasket (342) in place and fasten cover (341) with screws (341A). Be sure to connect pilot drain line to "Limit Switch Drain Port" in module adapter block (315), to drain.

E. VALVE MANIFOLD MODULE

Place o'ring (316) in groove of adapter block and use bolts (375A) to secure 4-way valve manifold (375) to module adapter block. With o'ring (377) in place, use screws (376A) to connect Port 9 flange (376) and piping assembly (378) to manifold. Place o'rings (377) in place and secure Port 8 and 9 flanges (379) with screws (379A).

F. CONTROL RATE MODULE

See reference material for assembly of flow control valves. Screw flow control valve assemblies (383) into (labeled "open" or "closed" on disassembly), corresponding bores of the flow control rate module (380). Being sure roll pin (384) is in place as well as o'rings (381, 382 and 385A), secure control rate module (380) to manifold (375) using lock washers (380B) and screws (380A).

G. VALVE MODULE

Consult individual manufactures literature for assembly of valve and pilot valve. Use screws (390A) to secure CETOP 4-way valve assembly (390) with o'rings, etc. to the flow control module.

H. CONNECTING AND MOUNTING

After entire prefill is assembled, and mounted, reconnect electrical and hydraulic connections to Ports 8, 10, 11 and 12.

NOTES

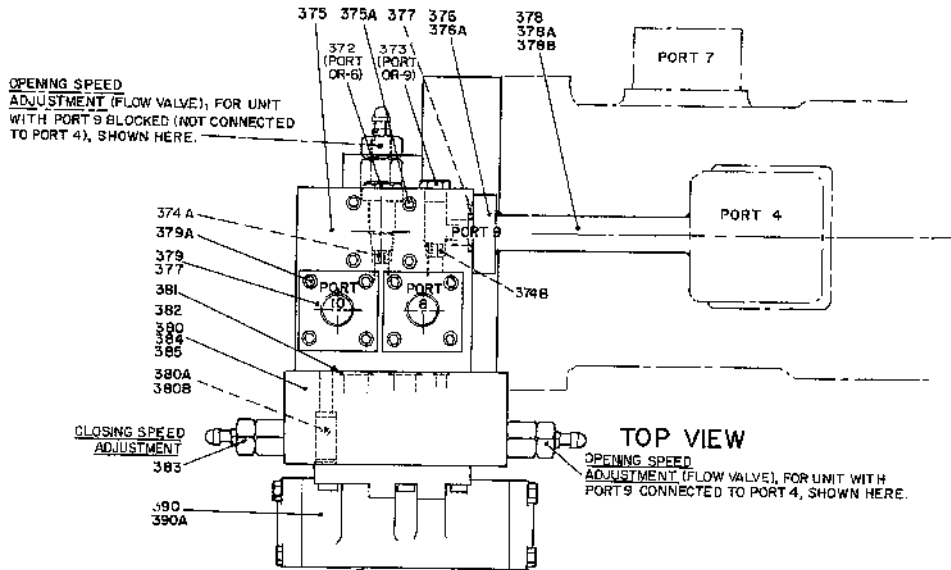

PARTIAL SECTIONED SIDE VIEW

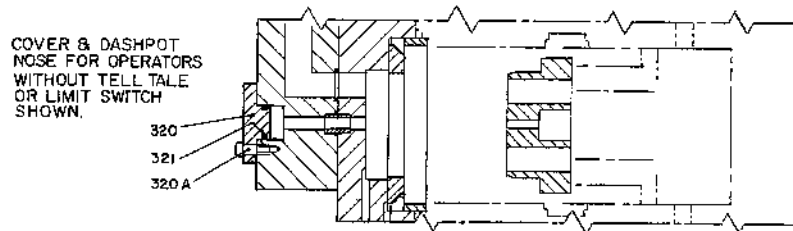
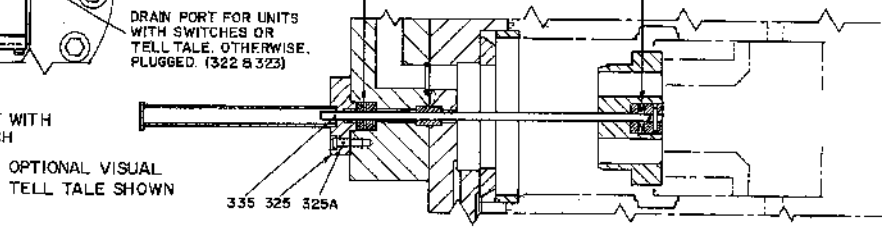
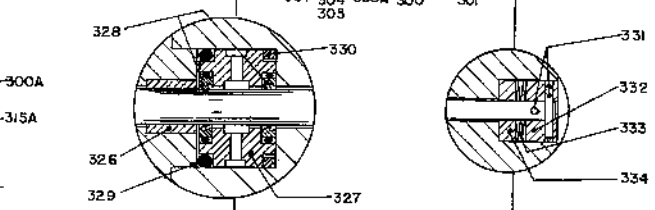
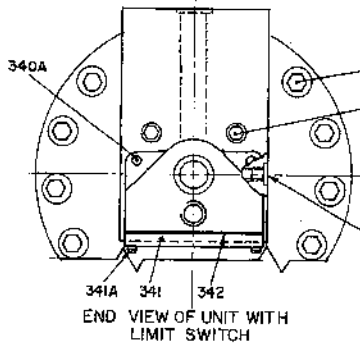
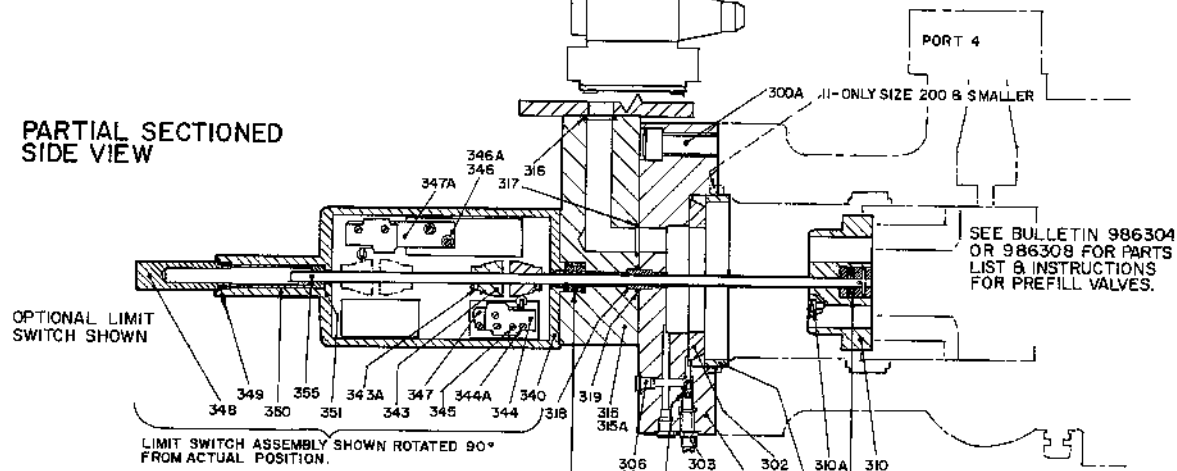

Figure 2. Parts Drawing, Modular 4-Way Valve Type Prefill Operator DS-986352 (516667).

X. PARTS LIST

Parts used in this assembly are per Oilgear specifications. Use Oilgear parts to ensure compatibility with assembly requirements. When ordering replacement parts, be sure to include prefill type designation, serial number, bulletin number and item number. To assure seal and packing compatibility, specify type of hydraulic fluid used.

ITEM NO.	DESCRIPTION	ITEM NO.	DESCRIPTION	ITEM NO.	DESCRIPTION
300	Head, Rear	325A	Screw, Sock. Hd. Cap	349	Seal, O'ring
300A	Screw, Sock. Hd. Cap	326	Bushing, Rod	350	Bushing, Back-up
301	Ring, Rear Head Locating	327	Retainer, Rod Seal	351	Bushing, Limit Switch Rod
302	Sleeve, Dashpot	328	Seal, Inner Rod	355	Rod, Limit Switch Tell Tale
303	Screw, Flow Choke	329	Seal, O'ring	375	Manifold, 4-Way Valve Operator
303A	Nut, Jam	330	Seal, Joint Ring	375A	Screw, Sock Hd. Cap
304	Seal, O'ring	331	Pin, Roll	376	Flange, Port 9
305	Ring, Back-up	332	Retainer, Outer Rod	376A	Screw, Sock. Hd. Cap
306	Plug, Hex	333	Washer, Spring	377	Seal, O'ring
307	Seal, O'ring	334	Retainer, Inner Rod	378	Pipe, Port 4 to 9
310	Nose, Dashpot	335	Rod, Visual Tell Tale	378A	Elbow Pipe (size 200)
310A	Screw, Nylock S.H.C.	340	Body, Limit Switch Enclosure	378B	Nipple, Pipe (size 200)
315	Block, Module Adapter	340A	Screw, Sock. Hd. Cap	379	Flange, Port 8 or 10
315A	Screw, Sock. Hd. Cap	341	Cover, Enclosure	379A	Screw, Sock Hd. Cap
316	Seal, O'ring	341A	Screw, Rd. Hd.	380	Module, Flow Rate Control
317	Seal, O'ring	342	Gasket, Enclosure	380A	Screw, Stacking
318	Bearing, Rod Sleeve	343	Cam, Limit Switch	380B	Washer, Lock
319	Seal, O'ring	343A	Screw, Set	381	Seal, O'ring
320	Cap, End	344	Switch, Micro	382	Seal, O'ring
320A	Screw, Sock. Hd. Cap	344A	Screw, Rd. Hd.	383	Assembly, Flow Control Valve
321	Seal, O'ring	345	Screw, Rd. Hd.	384	Pin, Roll
322	Plug, Hollow	346	Screw, Rd. Hd.	385	Plug, Hollow Hex.
323	Seal, O'ring	346A	Washer	385A	Seal, O'ring
325	Guard, Visual Tell Tale	347	Plate, Sub	390	Assembly, CETOP 4-Way Valve
		347A	Plate, Adapter	390A	Screw, Sock Hd. Cap.
		348	Cap, Limit Switch End		

O'RING SIZES

Cross Section x O.D. Duro ±5

ITEM NO.	PREFILL VALVE SIZE									
	200		250		300		350		400	
304	1/16 x 3/8	90	1/16 x 3/8	90	1/16 x 3/8	90	1/16 x 3/8	90	1/16 x 3/8	90
307	ARP 904		ARP 904		ARP 904		ARP 904		ARP 904	
316	1/8 x 1-3/8	90	1/8 x 1-3/8	90	1/8 x 1-3/8	90	1/8 x 1-3/8	90	1/8 x 1-3/8	90
317	1/8 x 1-1/4	90	1/8 x 1-3/8	90	1/8 x 1-3/8	90	1/8 x 1-3/8	90	1/8 x 1-3/8	90
319	3/32 x 7/8	90	3/32 x 7/8	90	3/32 x 7/8	90	3/32 x 7/8	90	3/32 x 7/8	90
321	1/8 x 1-1/8	90	1/8 x 1-1/8	90	1/8 x 1-1/8	90	1/8 x 1-1/8	90	1/8 x 1-1/8	90
323	ARP 904		ARP 904		ARP 904		ARP 904		ARP 904	
329	1/8 x 1-1/8	90	1/8 x 1-1/8	90	1/8 x 1-1/8	90	1/8 x 1-1/8	90	1/8 x 1-1/8	90
349	ARP 910		ARP 910		ARP 910		ARP 910		ARP 910	
377	1/8 x 1-1/2	90	1/8 x 1-1/2	90	1/8 x 1-1/2	90	1/8 x 1-1/2	90	1/8 x 1-1/2	90
381	1/8 x 1-5/16	90	1/8 x 1-5/16	90	1/8 x 1-5/16	90	1/8 x 1-5/16	90	1/8 x 1-5/16	90
382	ARP 014		ARP 014		ARP 014		ARP 014		ARP 014	
385A	ARP 908		ARP 908		ARP 908		ARP 908		ARP 908	



THE OILGEAR COMPANY
2300 So. 51st. Street
Milwaukee, WI 53219