

TWO-WAY PREFILL VALVES



Olmsted Products Co.

PREFILL SYSTEMS

Prefill valves provide a method by which the need for very large pumps may be avoided. In a typical prefill system the large main cylinder is filled and exhausted through the prefill valve. Traversing is accomplished with much smaller cylinders. This increases productivity through faster cycle times, saves weight and space, minimizes operational costs, and saves initial installation costs. In today's highly competitive industrial environment, the emphasis is on reliable performance. Maximum performance in any system is dependent on design integrity and quality of manufacture. You'll find both of these attributes in every Olmsted component and engineered system.

Olmsted's experience in supplying the industrial community with high flow, high pressure valving, and a significant effort in research and development, have resulted in a product that provides the marketplace the following benefits:

- Optimum flow efficiency and responsive system performance.
- Greater productivity through increased cycle rates.
- Mounting versatility, resulting in lower installation costs.
- Improved system reliability, resulting in reduced downtime.

PREFILL VALVE FEATURES

1. Piloted or face mounting assures easy installation and versatility. Ideal for retrofitting existing applications.
2. Metal to metal and elastomer seals provide maximum sealing effectiveness for optimum system performance.
3. Pilot-operated for maximum control and response.
4. Gauge ports for pressure diagnostics.
5. Pressure biased to close position to assure safe decompression level prior to opening.
6. Extremely fast shift times result in increased productivity.
7. Compact design offers significant weight and space savings.
8. 3-pin proximity switch provides electrical signal indicating valve position.
9. Metric interface available at all working ports.
10. 5,000 psi pressure port rating for maximum squeeze force.
11. Cushioned opening and closing reduces system shock.
12. Extrusion resistant, radial-type lip seal at piloted mounting interface allows increased mating part tolerances.
13. Shroud can be rotated to achieve different installation orientations or omitted for mounting in the reservoir.

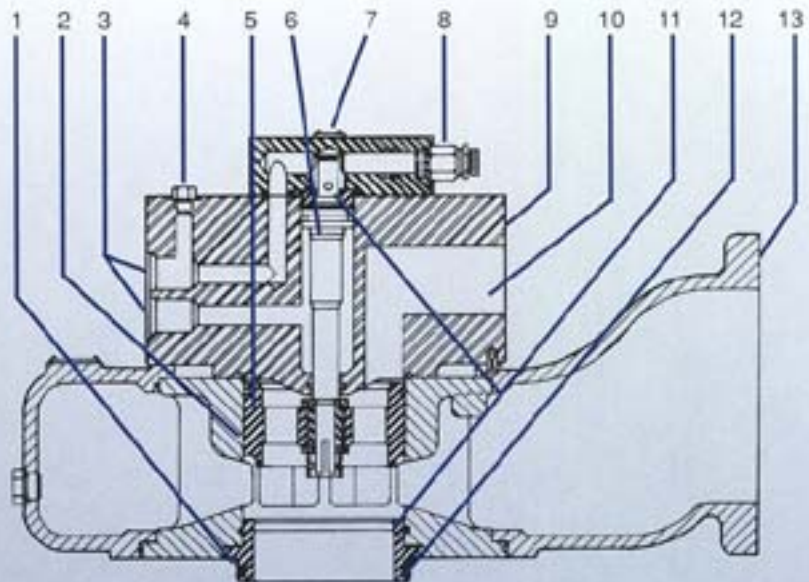

PREFILL VALVE MODEL CODE

PRT:****.*.*.*.*.*.*.*.*.*
1 2 3 4 5 6 7 8

1 PREFILL VALVE

2 TWO-WAY

3 MAIN PORT SIZES:

	CYLINDER PORT	LOW PRESSURE
0304	3"	4"
0406	4"	6"
0506	5"	6"
0808	6"	8"
0708	7"	8"
0911	9"	11"
1216	12"	16"

4 PORT INTERFACE STANDARD:

Blank = UNC threads at main port locations and
SAE ports at piloting locations

M = Metric threads at main port locations and
BSPF ports at piloting locations

5 MOUNTING AND DECOMPRESSION:

Blank = Bore seal

K = Bore seal and built in decompression

R = Face seal

RK = Face seal and built in decompression

6 SHROUD OPTIONS:

Blank = Right hand as shown

L = Left hand – rotated 180 degrees from
position shown

N = Reservoir mounting – no shroud
N/A for models PRT-0304 and 1216

7 PROXIMITY SWITCH:

Blank = No switch

H = Proximity switch required

8 DESIGN NUMBER: Subject to change

MODES OF OPERATION

Prefill valves accommodate five basic modes of machine operation: machine idle; rapid advance; work cycle; decompression; and return.

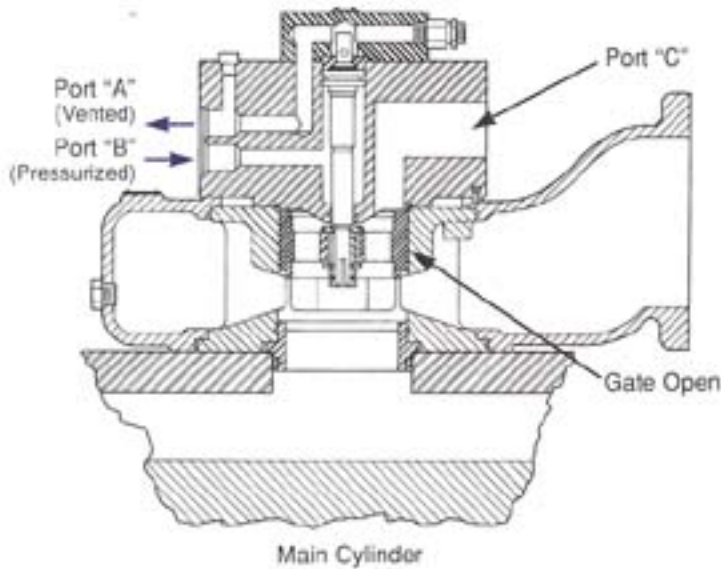

MACHINE IDLE

In this mode the valve is typically held open by supplying fluid to pilot port 'B'. The cylinder port and the pressure port 'C' are connected to the reservoir, thus eliminating any possibility of pressure buildup.

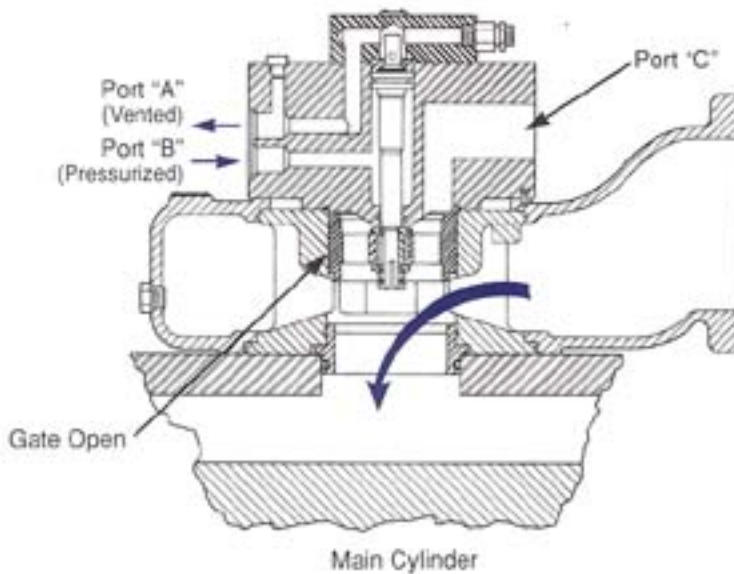

RAPID ADVANCE

During rapid advance the valve is held in the open position allowing fluid to flow from the reservoir and port 'C' to the main cylinder. As the cylinder approaches the work piece, the valve can be piloted closed by supplying pilot fluid to port 'A' while at the same time venting port 'B'.

WORK CYCLE

With the valve in the closed position, the cylinder is isolated from the reservoir. High pressure fluid introduced at port "C" builds pressure in the cylinder. When the work cycle is complete, the large volume of fluid in the cylinder must be decompressed prior to opening the prefill valve for the return stroke.

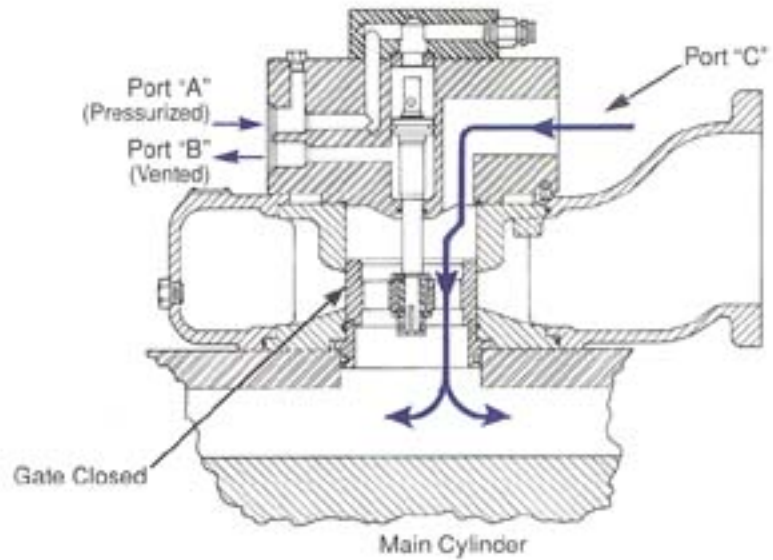

DECOMPRESSION

Decompression can be accomplished within the prefill valve by specifying the decompression option or it can be done through a separate valve located remotely from the prefill. The prefill valve remains closed during the decompression cycle. See page 9 for detailed recommendations on decompression.

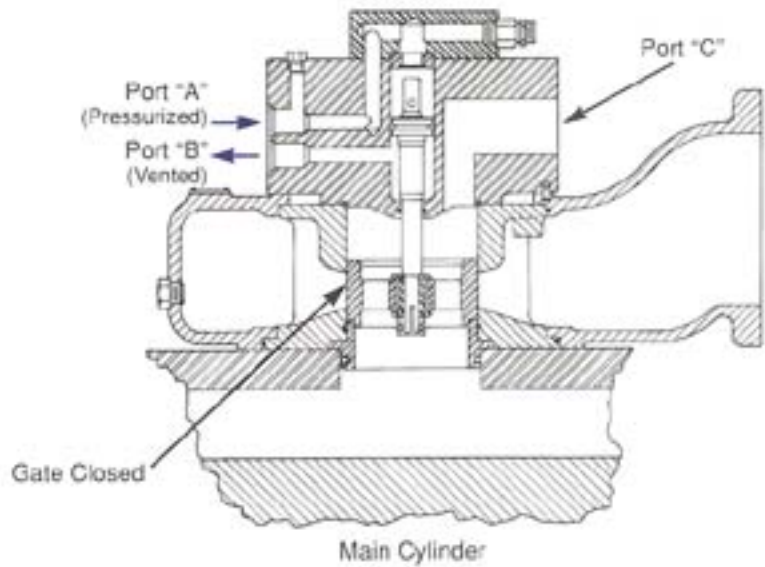

RETURN

After cylinder decompression, to approximately 250 psi, the prefill valve is piloted open by supplying pilot fluid to port "B" while venting port "A". This allows cylinder fluid to return to the reservoir through the prefill valve readying it for the next cycle.

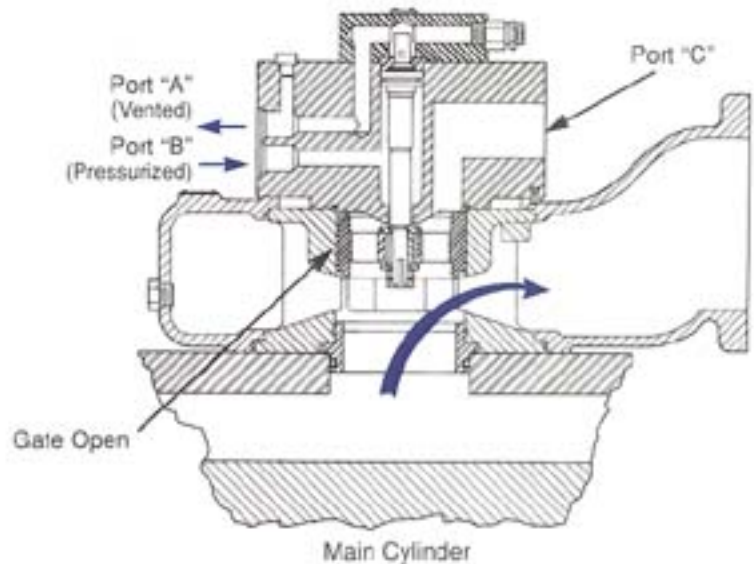

PREFILL VALVE SELECTION GUIDE

To select the proper size valve for your application, refer to the mounting position illustrations shown below. Next, choose the installation that best represents your particular application. Knowing the maximum flow, during rapid advance, select the proper valve size using the chart provided.

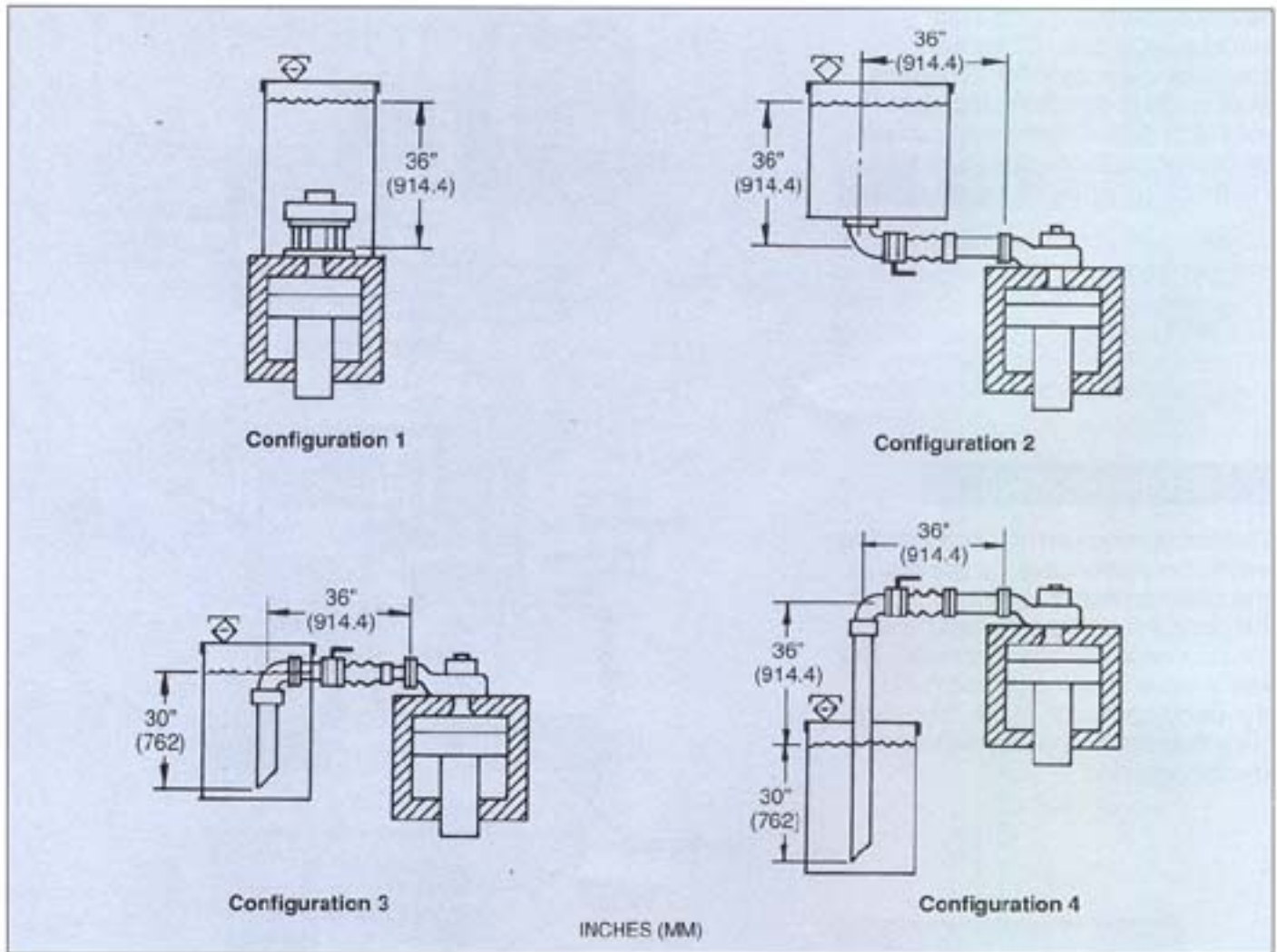

MAXIMUM FLOWS IN GPM (L/MIN)								
MOUNTING POSITION	PREFILL MODEL							
	PRT							
	0304	0406	0506	0608	0708	0911		1216
1	N.A.	736 (2786)	1195 (4524)	1773 (6712)	2474 (9365)	4200 (15897)		N.A.
2	480 (1820)	678 (2566)	1033 (3910)	1576 (5966)	2076 (7858)	*3459 (13094)	**3730 (14120)	6300 (23848)
3	453 (1713)	638 (2415)	969 (3668)	1479 (5599)	1935 (7325)	*3220 (12189)	**3500 (13249)	5910 (22372)
4	426 (1611)	600 (2271)	906 (3437)	1389 (5258)	1814 (6867)	*3020 (11432)	**3290 (12454)	5560 (21047)

Values based on hydraulic oil of .85 SP. GR. 150 SUS (32cSt) and 10 psi (.69) total system pressure drop
 * Based on 10 inch I.D. pipe ** Based on 12 inch I.D. pipe

PREFILL VALVE CAPACITIES

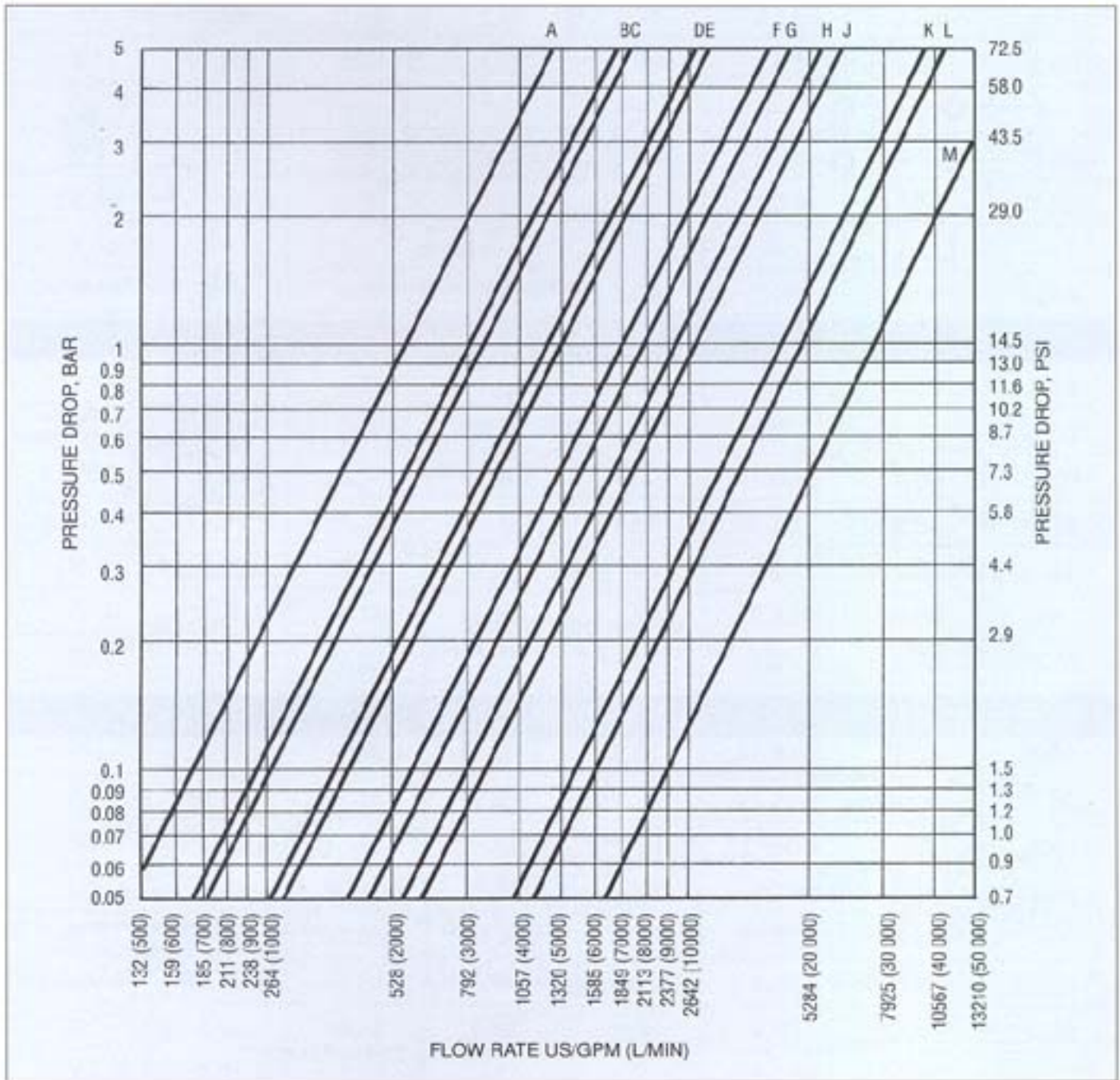

CURVE	VALVE	CURVE	VALVE
A	PRT-0304	G	PRT-0608 W/O SHROUD
B	PRT-0406	H	PRT-0708
C	PRT-0406 W/O SHROUD	J	PRT-0708 W/O SHROUD
D	PRT-0506	K	PRT-0911
E	PRT-0506 W/O SHROUD	L	PRT-0911 W/O SHROUD
F	PRT-0608	M	PRT-1216

PRESSURE PORT INTERFACE

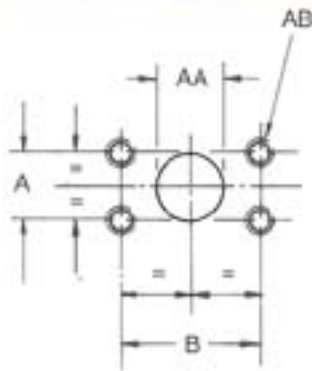

VALVE MOUNTING INTERFACE

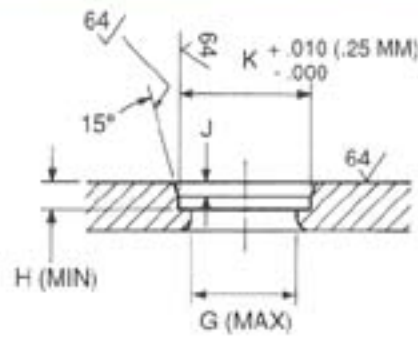

BORE SEAL MOUNTING

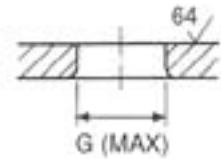

FACE SEAL MOUNTING

SHROUD INTERFACE

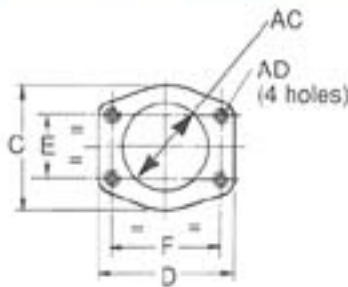

PRT-0304

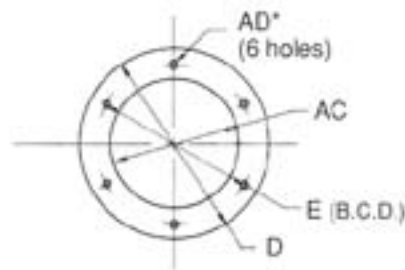

PRT-0406 THRU PRT-0911
* ROTATED 30° FOR METRIC MODELS

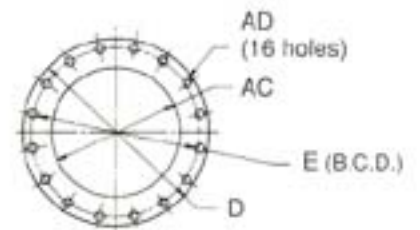

PRT-1216

VALVE DIMENSIONS

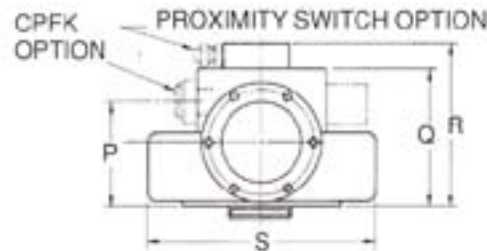
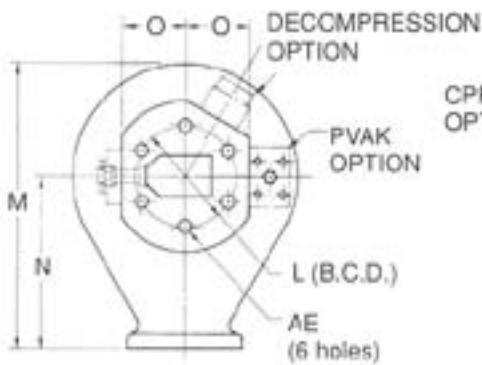

PRT-0304 THRU PRT-0911

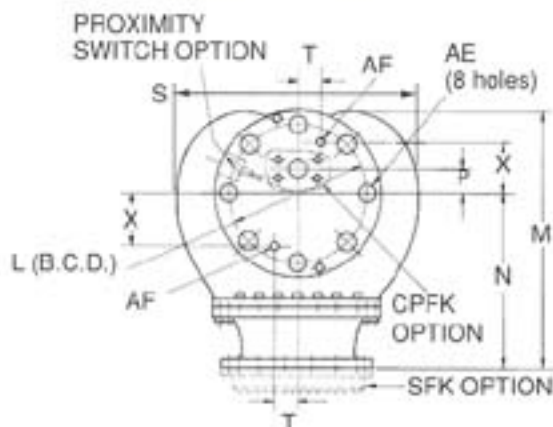
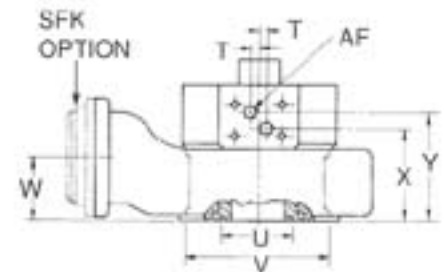

PRT-1216

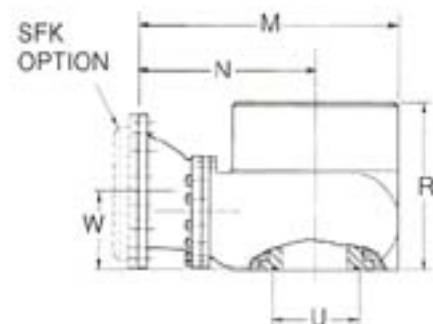

MODEL	0304	0406	0506	0608	0708	0911	1216
A	1.25	1.75	1.75	2.31	2.31	2.81	2.81
B	2.63	3.81	3.81	4.88	4.88	6.00	6.00
C	5.62	—	—	—	—	—	—
D	6.38	9.00	9.00	12.00	12.00	16.00	23.50
E	3.06	8.00	8.00	11.00	11.00	14.50	21.25
F	5.13	—	—	—	—	—	—
G	3.13	4.50	5.25	6.25	7.25	9.50	12.13
H	.62	1.06	1.06	1.06	1.06	1.06	1.25
J	.12	.19	.19	.19	.19	.19	.19
K	3.75*	5.00*	6.00*	7.25*	8.25*	10.50*	14.00*
L	5.88	7.50	8.25	11.00	11.00	15.00	21.00
M	12.75	21.00	21.00	24.63	24.63	32.00	40.12
N	7.25	12.38	12.38	14.00	14.00	18.50	27.25
O	3.75	5.12	5.50	7.12	7.12	8.69	—
P	6.62	7.82	7.82	11.21	11.21	15.65	3.75
Q	8.56	10.19	10.19	14.15	14.15	19.90	—
R	10.00	11.88	11.88	15.84	15.84	22.02	25.87
S	10.75	17.25	17.25	21.25	21.25	27.00	37.50
T	.38	.56	.56	.56	.56	.94	3.44
U	3.62	5.00	5.75	6.75	7.75	10.00	13.00
V	—	10.56	10.56	15.25	15.25	18.38	—
W	3.13	4.63	4.63	6.19	6.19	8.25	12.06
X	6.31	6.82	6.82	9.65	9.65	13.53	8.19
Y	7.81	7.94	7.94	11.21	11.21	14.90	—
AA	1.25	2.00	2.00	2.50	2.50	3.0	3.0
AB	½-13	¾-10	¾-10	7/8-9	7/8-9	1½-7	1½-7
AC	4.00	6.00	6.00	8.00	8.00	11.00	16.00
AD	5/8-11	½-13	½-13	½-13	½-13	½-13	1-8
AE	.81	1.06	1.06	1.56	1.56	2.06	2.62
AF	#8 SAE	#10 SAE	#10 SAE	#12 SAE	#12 SAE	#16 SAE	#16 SAE
* Tolerance +.010 (+.25 MM) -.000							

PREFILL PILOTING REQUIREMENTS

Model	Pilot volume to open		Pilot volume to close		Minimum recommended shifting time*
	in ³	cm ³	in ³	cm ³	
PRT-0304	1.27	21	1.70	28	50 MS
PRT-0406	1.89	31	2.80	46	50 MS
PRT-0506	1.89	31	2.80	46	50 MS
PRT-0608	6.70	110	10.20	141	75 MS
PRT-0708	6.70	110	10.20	141	75 MS
PRT-0911	15.70	257	22.30	365	80 MS
PRT-1216	35.30	578	46.80	767	95 MS

* For faster shifting speeds consult factory.

PRESSURE RATINGS

PORT "C"	5000 psi (345 bar) maximum
PORTS "A" & "B"	800 psi (55 bar) recommended
	3000 psi (207 bar) maximum
PORT "T"	25 psi (1.7 bar) maximum

NOTES ON PILOTING AND DECOMPRESSION

The recommended pilot pressure for Olmsted prefill valves is 800 psi. At this pilot pressure the valve will not open until the main cylinder has decompressed to the relatively safe valve of 250 psi. This is accomplished by pressure biasing the gate to the closed position. This feature allows the "pilot to open" signal to be given at the same time as the command to decompress the main cylinder, thus negating the need for a dedicated pressure switch for that function. **CAUTION:** If higher piloting pressures are used, and the "pilot to open" signal is given prior to decompressing the cylinder to a safe value, decompression shock may occur resulting in damage to the prefill valve and other system components.

PROXIMITY SWITCH CHARACTERISTICS

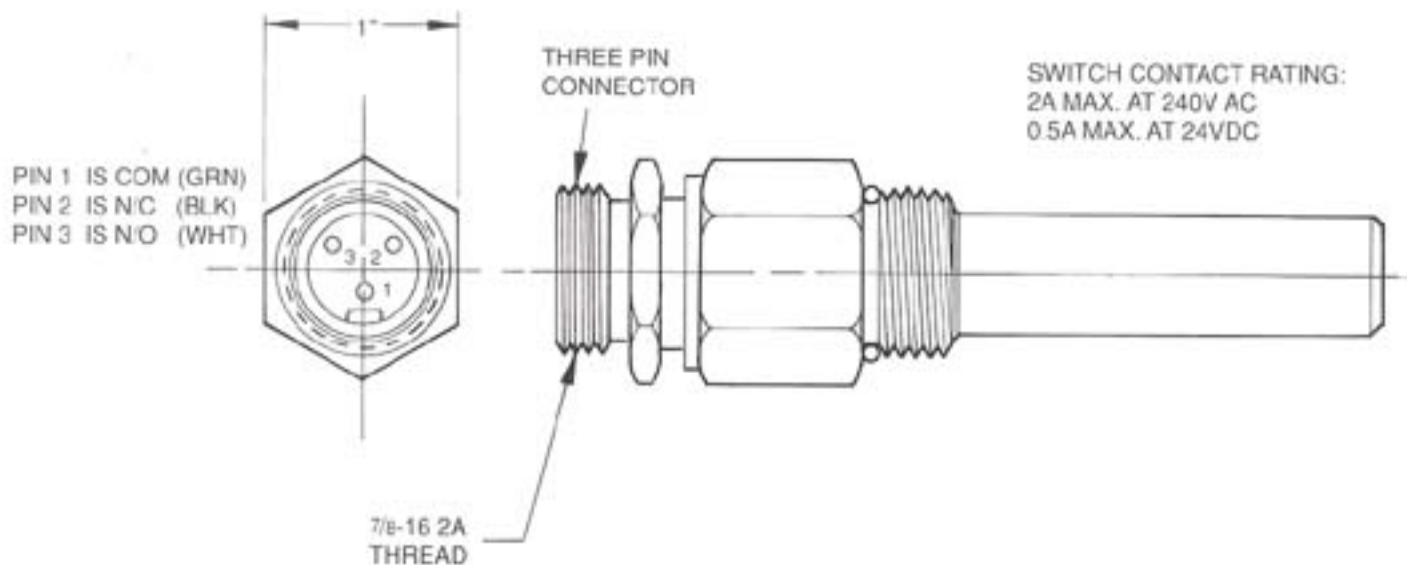

HYDRAULIC SYMBOLS

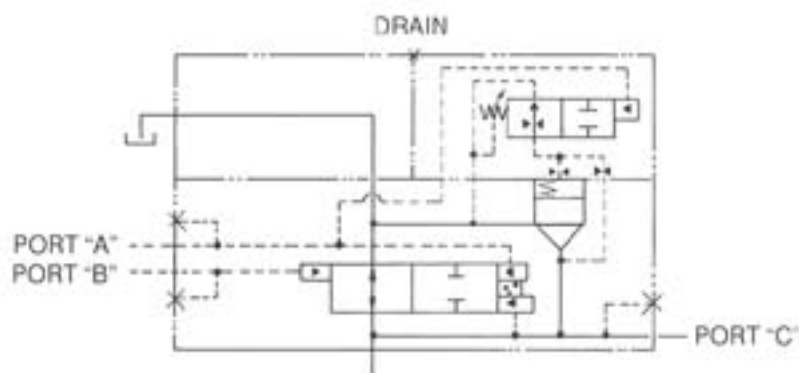
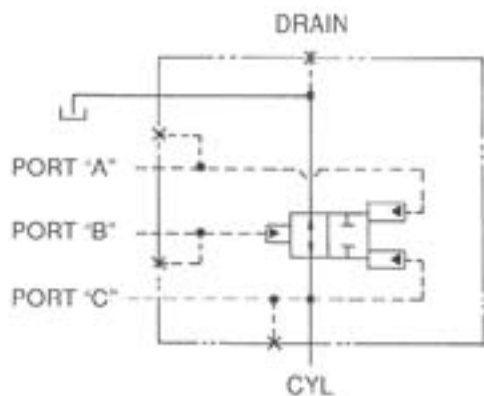

ACCESSORY PRODUCTS

Bolt kits BK0304 through BK1216.

Shroud flange kits SFK0304 through SFK1216.

Pilot valve adaptor kits PVAK0304 through PVAK0911.

Pressure port flange kits CPFK0304 through CPFK1216.

Contact the factory or your local Olmsted distributor for details on accessory products.