

**INSTALLATION DRAWING**

**Single Pressure Compensator Control w/Load Sense & Minimum Standby**

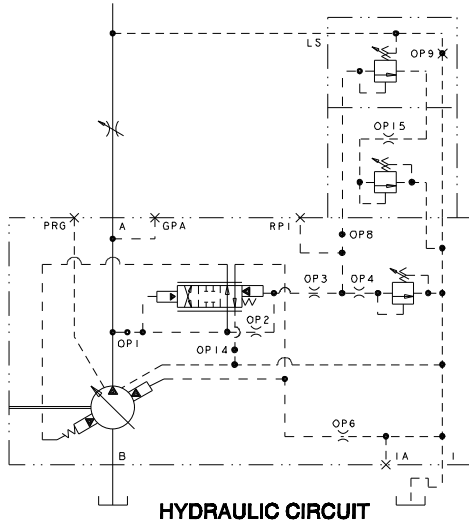

**HYDRAULIC CIRCUIT**

**NOTES:**

1. PUMPS DESIGNED FOR ONE-WAY SERVICE AND ARE DIMENSIONED AS SHOWN.
2. THESE UNITS ARE DESIGNED TO RUN CASE FULL OF FLUID AT ALL TIMES. FILL CASE BEFORE STARTING AND CONNECT DRAIN LINES ACCORDINGLY.
3. NUMERICAL DIMENSIONS GIVEN IN INCHES/[MM].
4. NET WEIGHT- 120 LBS [54 KG] FOR VERSION SHOWN  
130 LBS [59 KG] FOR THRU SHAFT VERSION.

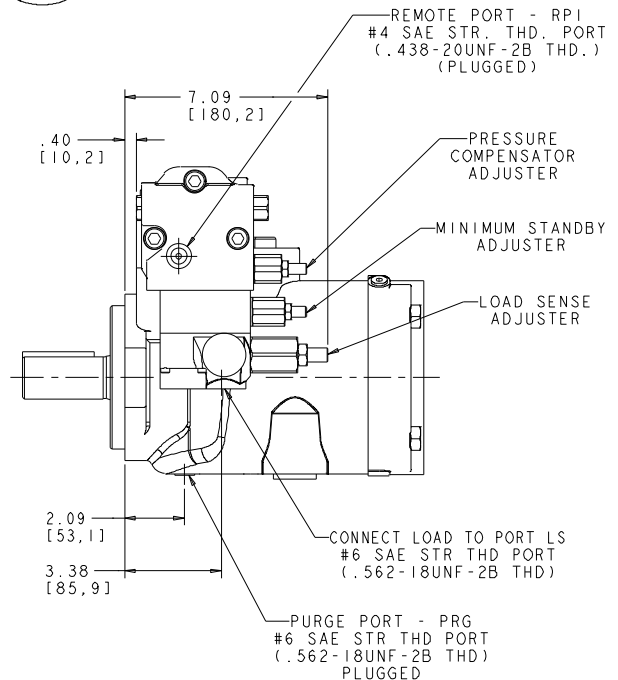
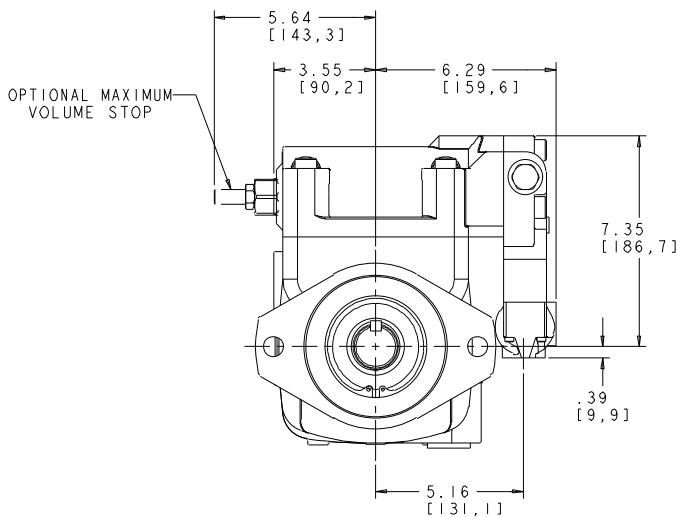
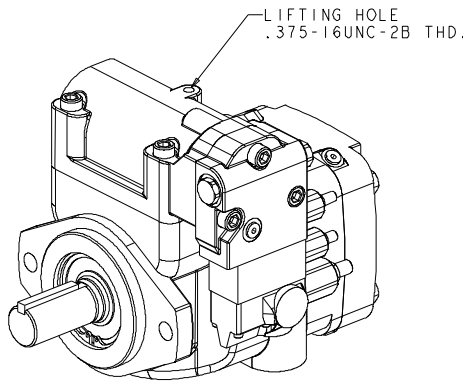

516152-224

FOR BASIC PUMP DIMENSIONS SEE PLANOGRAPHS:  
DS-47942, DS-47943 & DS-47944