

OILGEAR TYPE "DX" PUMPS

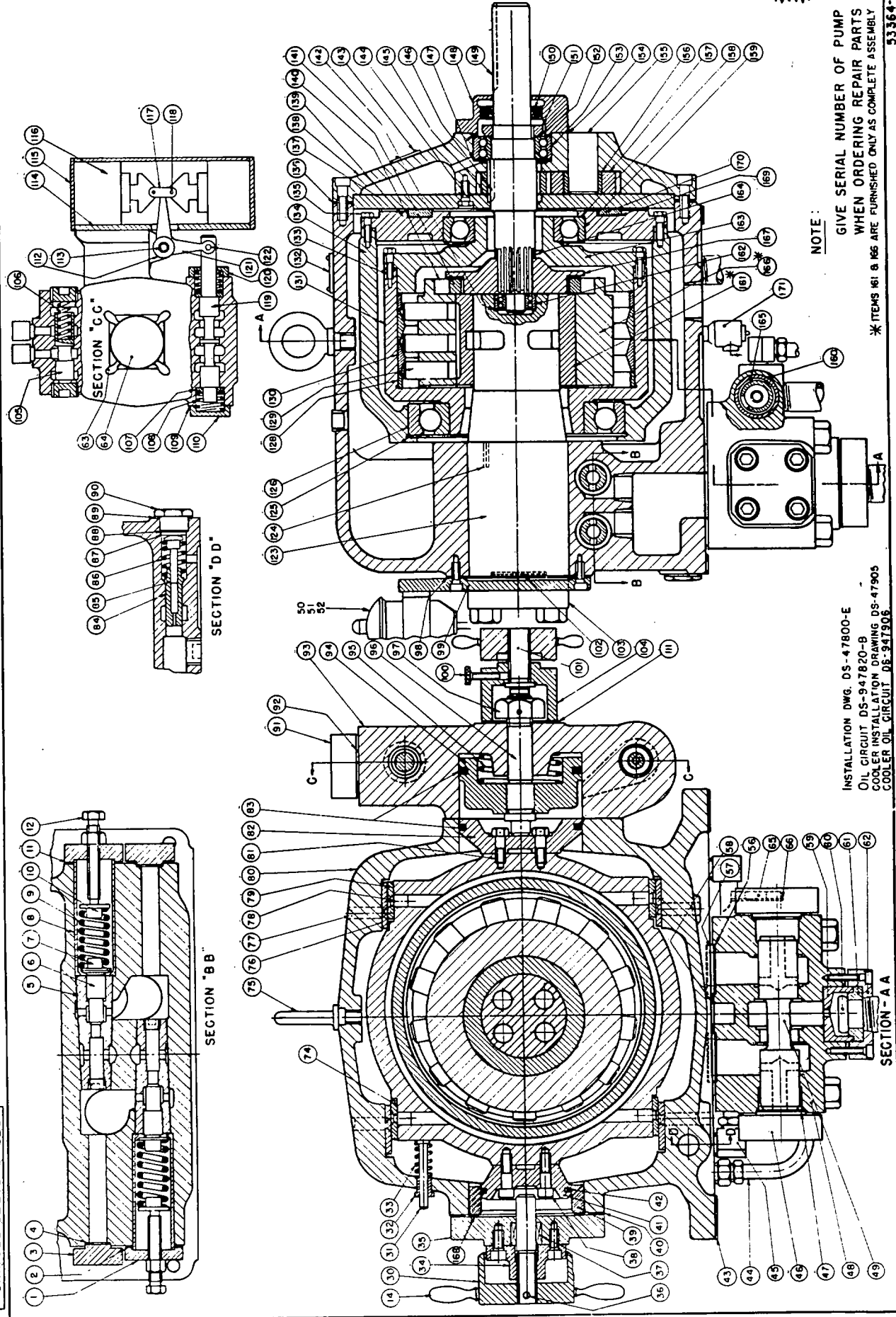

NOTE:

GIVE SERIAL NUMBER OF PUMP
WHEN ORDERING REPAIR PARTS
* ITEMS 161 & 166 ARE FURNISHED ONLY AS COMPLETE ASSEMBLY

INSTALLATION DWG. DS-47800-E
OIL CIRCUIT DS-947820-B
COOLER INSTALLATION DRAWING DS-47905
COOLER OIL CIRCUIT DS-947306

REPAIR PARTS DRAWING
OILGEAR TYPE "DX" PUMPS
DROSCH
TROSPER
53364-D

THE OILGEAR CO.
MILWAUKEE 4, WISCONSIN, U.S.A.

DS-94780I-D

REISSUED MAR. 1, 1951

53364-D

PARTS LIST
OILGEAR "DX" PUMPS

NO.	PARTS	NO.	PARTS	NO.	PARTS
1.	Cap, H.P.R.V.	58.	Gasket, H.P. Exhaust	115.	Cover, Solenoid
2.	Gasket, Cap	59.	Cage, Check Valve	116.	Solenoid, Pull-Type
3.	Flange, Auxiliary	60.	Disc, Check Valve	117.	Link, Solenoid
4.	Gasket, Flange	61.	Seat, Check Valve	118.	Pin, Link
5.	Bushing, H.P.R.V.	62.	Flange, Check Valve	119.	Plunger, Pilot Valve
6.	Plunger, H.P.R.V.	63.	Handle, Control	120.	Head, Valve
7.	Seat, Spring	64.	Knob, Control	121.	Lever, Operating
8.	Retainer, H.P.R.V. Bushing	65.	Cap, B.P.R.V.	122.	Pin, Lever
9.	Spring, H.P.R.V.	66.	Gasket, B.P.R.V. Cap	123.	Pintle
10.	Seat, Spring	67.		124.	Key, Pintle
11.	Shim, H.P.R.V. Retainer	68.		125.	Shim, Rear Rotor Bearing
12.	Screw, H.P.R.V. Adjusting	69.		126.	Bearing, Rear Rotor
13.		70.		127.	
14.	Handle, Control	71.		128.	Ring, Spacer
15.		72.		129.	Piston
16.		73.		130.	Ring, Thrust
17.		74.	Shim, Liner	131.	Rotor
18.		75.	Eyebolt	132.	Nameplate
19.		76.	Liner, Case	133.	Screw, Rotor Cover
20.		77.	Dowel, Case Liner	134.	Slide Block
21.		78.	Dowel, Slide Block Liner	135.	Screw, Slide Block Cover
22.		79.	Liner, Slide Block	136.	Gasket, G.P. Housing
23.		80.	Case	137.	Cover, Gear Pump
24.		81.	Screw, Piston	138.	Housing, Gear Pump
25.		82.	Piston, Large Control	139.	Cover, Slide Block
26.		83.	Ring, Piston	140.	Roller, Coupling
27.		84.	Plunger, G.P.R.V.	141.	Ring, Coupling
28.		85.	Plunger, G.P.R.V. Dashpot	142.	Shim, Rear Shaft Bearing
29.		86.	Spring, G.P.R.V.	143.	Plate, Rotation Direction
30.	Knob, Control	87.	Spacer, G.P.R.V.	144.	Screw, G.P. Cover
31.	Stem, Indicator	88.	Shim, G.P.R.V.	145.	Gear, G.P. Driver
32.	Bushing, Indicator	89.	Gasket, G.P.R.V. Cap	146.	Key, Gear Pump
33.	Spring, Indicator	90.	Cap, G.P.R.V.	147.	Shim, Front Shaft Bearing
34.	Gland, Adjusting Screw	91.	Flange, Control H.P.	148.	Cover, Shaft Seal
35.	Head, Small Con. Cylinder	92.	Gasket, Flange	149.	Shaft, Drive
36.	Screw, Adjusting	93.	Head, Cylinder	150.	Seal, Shaft
37.	Packing, Screw	94.	Piston, Control	151.	Nut, Bearing Lock
38.	Screw, Control Piston	95.	Spring, Piston	152.	Washer, Bearing Lock
39.	Adapter, Cylinder	96.	Screw, Adjusting	153.	Bearing, Front Shaft
40.	Gasket, Cylinder Head	97.	Nut, Lock	154.	Gasket, Shaft Seal Cover
41.	Piston, Control	98.	Gasket, Cover	155.	Shaft, G.P. Stub
42.	Ring, Piston	99.	Cover, Pintle	156.	Bushing, Driven Gear
43.	Gasket, Mounting Pad	100.	Screw, Thumb	157.	Gear, G.P. Driven
44.	Tubing, Supercharge	101.	Screw, Adjusting	158.	Shim, Front Rotor Bearing
45.	Tubing, Control Pressure	102.	Gasket, Flange	159.	Bearing, Front Rotor
46.	Flange, Suction Valve	103.	Flange, Pipe Conn.	160.	Plunger, B.P.R.V.
47.	Gasket, Flange	104.	Gland, Adj. Screw	161.	Bushing, Cylinder*
48.	Body, Suction Valve	105.	Plunger, Valve	162.	Bearing, Rear Shaft
49.	Plunger, Suction Valve	106.	Spring, Valve	163.	Cover, Rotor
50.	Filter, Oil	107.	Seat, Spring	164.	Spacer, Coupling
51.	Valve, Flow Control	108.	Spring, Pilot Valve	165.	Spring, B.P.R.V.
52.	Gage, Change Indicator	109.	Gasket, Valve Head	166.	Cylinder*
53.		110.	Head, Blind Valve	167.	Flange, Coupling
54.		111.	Gasket, Gland	168.	Gasket, Adapter
55.		112.	Collar, Lever	169.	Shim, Slide Block Spacer
56.	Gasket, Spacer	113.	Pin, Lever	170.	Ring, Slide Block Spacer
57.	Spacer	114.	Plate, Solenoid Mounting	171.	Valve, 5# Relief

*Parts 161 and 166 furnished only as a complete assembly.

NOTE: When ordering parts be sure to give serial number of pump.